



ENGINEERING DATA

SECTION	SUBJECT	PAGE
1	Introduction/Tire Selection	1
	Off-The-Road Tires Introduction	1
	Construction Features	2
	Tire and Rim Selection, Definitions of Terms	3
	Industry Code Identification	6
	Tire Markings	7
	Ton-Mile-Per-Hour Formula	8
	Work Capability Factor	9
	Mixing of Bias and Radial Tires on Vehicle	11
	Comparative Size Chart	12
	Historic Tire Nomenclature	13
	Conversion Factors for Dimensional Data	14
	Tire Dimensions	15
2	Dimensional Data/Load Limits	17
	Conventional Size	17
	Wide Base Size	69
	65 Series	115
	Metric Size	125
	Underground Mine	127
3	Load Variations	141
	Drive Away	141
	Load Index - Kilogram loads, and TRA equivalent pound loads	147
	Load/Speed Variation - Highway	150
	Load/Speed Variation - Off-The-Road	151
4	Tire Shipping Data - Tire Weights and Tire Shipping Volumes	152
5	Tubes - Flaps - Valves - Rims	166

OFF-THE-ROAD TIRES INTRODUCTION

GENERAL NOTES AND INFORMATION

AVAILABILITY

Sizes listed in this book include tires currently available on a global basis and tires previously made but no longer produced. "Current In Line Locations" are regions of the world where the tire is produced or inventoried and available for sale.

For current availability of specific sizes and types of tires contact your Goodyear Representative.

Construction All tires are reinforced with nylon cords, except Unisteel Radial Ply tires, which are reinforced with steel cords.

Dimensional Data Dimensions of tires are for tires on design rims.
Dimensions on other rims are the same except for tire widths. Change tire widths 0.4" (10mm) for each 1" (25.4mm) change in rim width.

Inflation Pressure The inflation pressures shown in this data book are those taken with the tires at approximately the prevailing atmospheric temperatures and do not include any build-up due to vehicle operation.

RIMS

Selection of Rims For information on rim selection see Pages 3-5.

Strength and Application of Rims Contact your rim supplier regarding information on rim strength, application and maximum inflation pressure.

Rim & Wheel Restrictions For information on rim & wheel restrictions consult rim manufacturer.

Suffix Letters For information on suffix letters, see Page 6.

Tire Codes Industry Tire Type Codes, as approved by the Tire and Rim Association, are shown whenever such codes are assigned to specific tires. (This code is used as industry comparison reference of Off-The-Road Tires regardless of the manufacturers' design name See Page 6).

Tire Selection For information on tire selection see Page 3.

Valves Consult your Valve Supplier for valve information. Also see Pages 166-172.

CONSTRUCTION FEATURES

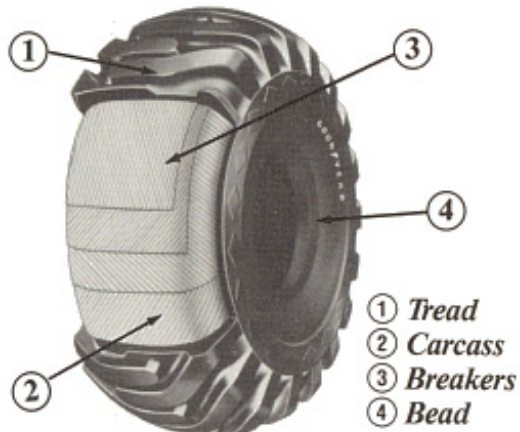

Fig. 1 Bias Tire

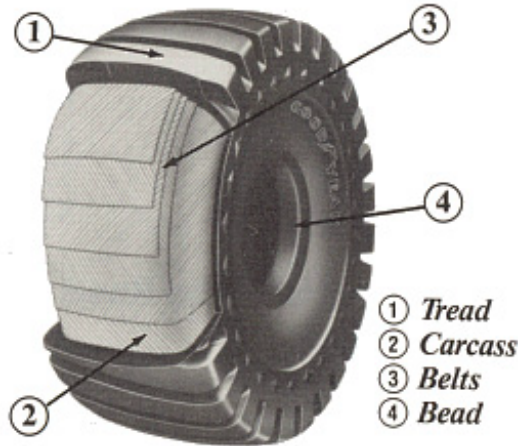

Fig. 1B Bias/Belted Tire

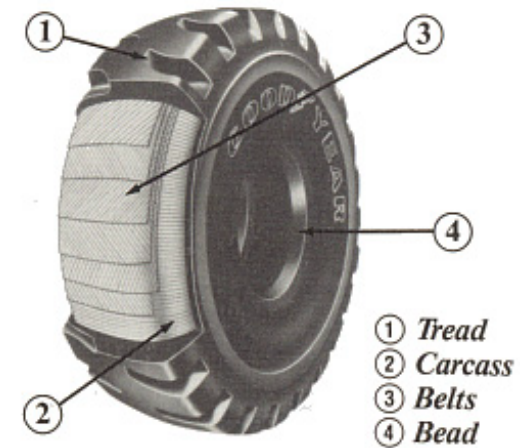

Fig. 1C Radial Tire

Basic Design

Earthmover tires are produced in three basic constructions:

- Bias
- Bias/Belted
- Radial

All share a common nomenclature.

Tread

The part of the tire in contact with the ground. It must provide traction, long wear and cut resistance. The tread depth and design vary based on site and application.

Carcass

Contains the inflation medium. The greater its strength, the greater the pressure it can hold. Bias and bias/belted tire carcasses use many angled plies of fabric to achieve strength. Radials have one ply of steel wire.

Breakers (Belts)

These are placed between the tread and carcass. They help to join these parts. They also distribute road shock to protect the carcass. In bias/belted and radial constructions, they control the diameter of the tire. They also impart superior tread impact and penetration resistance.

Bead

Bundles of high tensile steel wire. They anchor the tire to the rim. Bias and bias/belted tires may have several bead bundles. Radials have one large bead bundle.

Sidewalls

The protective rubber cover on the side of a tire. The rubber is compounded to flex without cracking. It also resists cuts and forms a barrier to protect the carcass from the weather.

Inner Liner

Aspecially formulated rubber compound inside the tire that minimizes permeation. It works with the rim and O-ring to contain the inflation medium in tubeless designs.

SELECTION OF TIRES AND RIMS FOR OFF-THE-ROAD VEHICLES AND DEFINITIONS OF TERMS

TIRE SELECTION

NEW VEHICLE DESIGN - Proper tire size and ply rating selection shall be based on Gross Tire Load and the operating conditions specified in the table from which the tire is being selected. Gross tire loads shall be based on the highest individual wheel load determined by the Gross Vehicle Weight (GVW) distribution.

For New Haulage, Dozer and Loader Vehicle Design, the following maximum inflation pressures with the corresponding loads shown in the applicable tables are recommended to obtain optimum tire performance:

	Diagonal (Bias) Ply	Radial Ply
Wide Base	58 psi (4.0 Bar)	69 psi (4.75 Bar)
Conventional	73 psi (5.0 Bar)	83 psi (5.75 Bar)
"65 Series"	62 psi (4.25 Bar)	73 psi (5.00 Bar)

For New Vehicle Design, the maximum load per tire shall not be greater than specified in applicable tables.

VEHICLES IN OPERATION - Due to the specialized nature of Off-The-Road vehicle usage, loads in excess of those in the appropriate TRA load tables are often encountered. These excess loads result from items such as actual vehicle weight exceeding the design weight, varying density of materials, field modifications to the equipment, load transfer, etc. Under these conditions, the actual tire load in service may exceed the TRA load ratings in the tables for the tire by an amount not greater than shown in the following table:

	Load	* Pressure
Bias (Diagonal) Ply	15% Daily Average Overload 22% Maximum Single Journey Overload	30%
Radial	7% Daily Average Overload 14% Maximum Single Journey Overload	14%

* When excess loads are encountered, cold inflation pressures must be increased to compensate for higher loads. For each 1% increase in load, the inflation pressure must be increased by 2%.

NOTE: These load and inflation allowances do not apply to filled tires since the internal tire cavity pressure can not be increased.

The above excess loads will result in reduced tire performance and **MUST BE APPROVED BY THE TIRE MANUFACTURER.**

IMPORTANT: Since increased tire loads and inflation pressures might exceed the rim and wheel capacity, **RIM OR WHEEL MANUFACTURERS MUST BE CONSULTED.**

SELECTION OF TIRES AND RIMS FOR OFF-THE-ROAD VEHICLES AND DEFINITIONS OF TERMS

DEFINITION OF TERMS FOR OFF-THE-ROAD TIRES

GROSS TIRE LOAD - Gross Tire Loads are based on the highest individual wheel load determined by the distribution of the Gross Vehicle Weight (GVW), including weight transfer. The maximum GVW shall include, but not be limited to, the following:

- 1) **Net Weight** - Actual weight of the vehicle with standard equipment including the maximum capacity of engine fuel, oil, coolant and operator.
- 2) **Accessory Weight** - The combined weight of all optional items installed on the equipment not previously considered in Net Weight. These include such items as air conditioners, special cabs, body liners, side boards, special reinforcements, etc.
- 3) **Payload** - The total weight of the material being carried.

- SERVICE CONDITIONS -**
- 1) **Earthmover (Haulage)** - A haulage cycle where equipment self-loads or receives a load from loading equipment, then transports this load to another location and returns unloaded. Transportation usually occurs over unimproved surfaces at medium speeds, up to 40 mph (64 kph), and short distances, up to 2.5 miles (4 Km), one way. Equipment in this category consists mainly of haulage trucks and scrapers.
 - 2) **Loader** - This is a work cycle where the equipment is used to pick up material and relocate a short distance away. Tire loads fluctuate depending on the conditions involved when the equipment picks up the load. Transportation speeds are low, up to 5 mph (10 kph), and distances are short, a maximum of 250 feet (76m), one way.
 - 3) **Load and Carry** - A work cycle where equipment primarily intended for loader service picks up a load and transports this load to another location and returns unloaded. Transportation usually occurs over unimproved surfaces at low speeds, up to 15 mph (24 kph), and rather short distances, up to 2,000 feet (610m). Equipment in this category consists mainly of loaders, log stackers and material handling equipment.
 - 4) **Dozer** - A working condition where equipment is used to move materials (usually earth) by pushing, dragging or grading. Tire loads are relatively constant and speeds are low, up to 5 mph (10 kph). Travel distances vary depending on work situations.
 - 5) **Grader** - A working condition where equipment is used in construction and road maintenance. Tire loads are relatively constant during the work cycle. Equipment speeds are slow during working periods with maximum transportation speeds reaching 25 mph (40 kph). Travel distances vary depending on work situations.
 - 6) **Creep** - Movement of equipment at a very slow speed (not over 200 feet (61m) in 30 minutes). During creep motion, loads on the tires are very high and consideration must be given to the type of surface over which the equipment is traveling.
 - 7) **Drive-Away** - A term used to define movement of a vehicle from one location to another under non-working conditions. This movement occurs during transportation of equipment from site to site. Load/Speed/Distance tables for off-road service are not applicable to drive-away conditions. A separate set of load tables is supplied in this book for drive-away conditions.
 - 8) **Smooth Floors and Runways** - are defined as paved or protected operating surfaces which are free of undulations, obstructions or discontinuities.
 - 9) **Maximum Speed** - The peak speed attained by the vehicle during any part of a cycle (loaded or unloaded).

SELECTION OF TIRES AND RIMS FOR OFF-THE-ROAD VEHICLES AND DEFINITIONS OF TERMS

- TIRE TYPE NOMENCLATURE** -
- 1) **Conventional** - The cross-section shape of the tire has an aspect ratio (ratio of section height to section width) in the range of .95. Conventional tires are also referred to as narrow base tires.
 - 2) **Wide Base** - The cross-section shape of this tire has an aspect ratio in the range of .83.
 - 3) **"65 Series"** - This is a low profile tire with the aspect ratio in the range of .65.

RIM SELECTION

IMPORTANT - Rim dimensions are standardized by the Tire and Rim Association for size and contour only, and particular tire and rim combinations designated to assure proper mounting and fit of the tire to the rim. The load and cold inflation pressure imposed on the rim and wheel must not exceed the rim and wheel manufacturers' recommendations even though the tire may be approved for a higher load or inflation. Rims and wheels may be identified (stamped) with a maximum load and maximum cold inflation rating. For rims and wheels not so identified or for service conditions exceeding the rated capacities, consult the rim and wheel manufacturer to determine rim and wheel capacities for the intended service.

LOADS/INFLATIONS

NOTE: English loads and inflations are TRA (USA) standards. Metric loads are ETRTO norms except where a size or ply rating is not covered by ETRTO. In these cases, TRA (USA) SI standards are used. Metric inflations are Goodyear recommendations. English and metric loads are not directly convertible.

Rated loads are based on cyclic operations.

INDUSTRY CODE IDENTIFICATION

INDUSTRY CODE IDENTIFICATION FOR OFF-THE-ROAD TIRES

SERVICE

- C - Compactor Service
- E - Earthmover Service
- G - Grader Service
- L - Loader & Dozer Service

EARTHMOVER SERVICE

Code	Tread Type	Percent Tread Depth
E-1	Rib	100
E-2	Traction	100
E-3	Rock	100
E-4	Rock deep tread	150
E-7	Flotation	80

LOADER & DOZER SERVICE

Code	Tread Type	Percent Tread Depth
L-2	Traction	100
L-3	Rock	100
L-4	Rock deep tread	150
L-5	Rock extra deep tread	250
L-3S	Smooth	100
L-4S	Smooth deep tread	150
L-5S	Smooth extra deep tread	250

GRADER SERVICE

Code	Tread Type	Percent Tread Depth
G-1	Rib	100
G-2	Traction	100
G-3	Rock	100
G-4	Rock deep tread	150

COMPACTOR SERVICE

Code	Tread Type	Percent Tread Depth
C-1	Smooth	100
C-2	Grooved	100

SUFFIX LETTERS USED BY THE TIRE AND RIM ASSOCIATION IN TIRE SIZE DESIGNATIONS AND THEIR DEFINITIONS

Suffix letters are included, when necessary, as part of Tire Size Designations to differentiate between tires for service conditions which may require different loads and inflations and/or tires and must be used on different types of rims.

- NHS** Not for highway service.
- TG** Tractor-Grader tires - Not for highway service.
- ML** Mining and Logging Tires used in Intermittent Highway Service.
- DT** Tires primarily for use in sand service.
- K** Compactor tire for use on drop center or semi-drop center rims.

TIRE MARKINGS

Symbol marking of Radial Ply Tires

Radial earthmover tires use a simplified symbol (star) marking system as an indication of minimum recommended inflation for a particular tire load carrying capacity.

	Symbol	Inflation			
		30 mph PSI	50 kph BAR	5 mph PSI	10 kph BAR
Narrow base sizes	*	69	4.75	80	5.50
	**	102	7.00	120	8.25
	***	116	8.00	131	9.00
Wide base sizes	*	54	3.75	73	5.00
	**	76	5.25	94	6.50
	***			145	10.00

Example: Earthmover (cyclic) applications

Service Description

In addition, these tires are marked with a "Service Description" located near the tire size marking. This consists of a code which indicates operating limits of loads and speeds and includes "load indices" for single tire fitment and "speed symbols" which relate to these indices (e.g. 202A2/180B).

This means that the tire may be used with the following maximum load/speed combination:

202 = 33,100 lbs/15,000 kg at A2 = 5 mph/10 kph

180 = 17,600 lbs/8,000 kg at B = 30 mph/50 kph

The position of the major tire markings are as shown:

- 1 - Tire section width (mm or inches)
- 2 - Aspect ratio S.H/S.W.
- 3 - Radial construction (R = Radial)
- 4 - Rim diameter (inches)
- 5 - Tubeless
- 6 - Goodyear tire name
- 7 - Star marking
- 8 - Load Index/Speed Symbol (Maximum Load/Speed combination)
- 9 - Compound/construction code

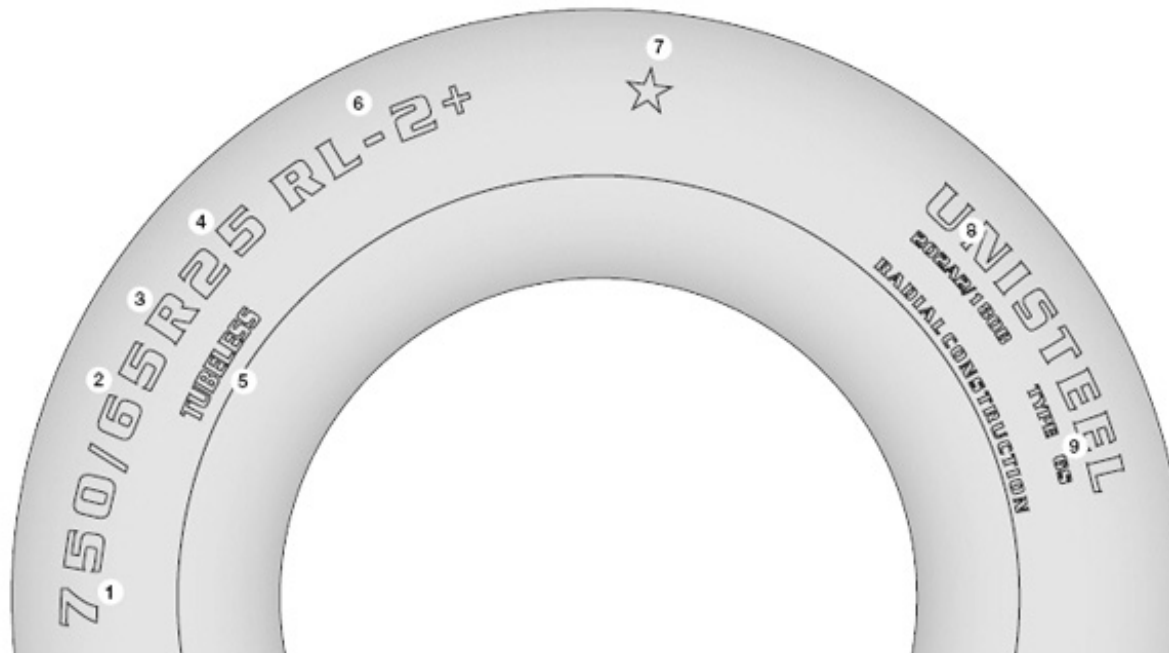

TON-MILE-PER-HOUR-FORMULA

CALCULATE JOB TMPH REQUIREMENTS FOR EVERY JOB
AVOID PREMATURE HEAT RELATED REMOVALS BY INSURING TIRES
ARE RATED AT OR ABOVE JOB REQUIREMENTS.

The TMPH Formula:

Multiply the average tire load times the average speed per hour to determine the Ton-Mile-Per-Hour Rating.

TMPH Job Rate

Average Tire Load x Average Speed for the shift

Average Tire Load

$$\frac{\text{"Empty" tire load in tons} + \text{"loaded" tire load in tons}}{2}$$

Average Speed

$$\frac{\text{Round trip distance in miles} \times \text{number of trips}}{\text{Total Hours (in the shift)}}$$

COMPOUND AND CONSTRUCTION COMBINATIONS

Compound Description	Compound Code
Heat Resistant (HR)	2
Standard	3
Standard Cut Resistant (CR)	4
Ultra Cut Resistant (UCR)	6

Construction Description	Construction Code
Standard	S
Heavy Duty	H
Extra Heavy Duty	HW
Steel Breakers	J
Heavy Undertread	U
Low Angle Belts	SL

SAMPLE TMPH CALCULATION:

Conditions:

- Empty vehicle tire load = 20,000 pounds (10.0 tons)
- Loaded vehicle tire load = 34,000 pounds (17.0 tons)
- Number of Hours Worked = 8.0 hours
- The shift hauls 15 loads.
- Each haul is 9.0 miles, round trip.

CALCULATION:

$$\text{Avg. Tire Load} = \frac{10 \text{ Tons} + 17 \text{ Tons}}{2}$$

$$\text{Avg. Tire Load} = \frac{27 \text{ Tons}}{2} = 13.5 \text{ Tons}$$

$$\text{Avg. Shift Speed} = \frac{9 \text{ Miles Per Trip} \times 15 \text{ Trips Per Shift}}{8.0 \text{ Hours Worked Per Shift}}$$

$$\text{Avg. Shift Speed} = \frac{135 \text{ Miles}}{8.0} = 16.9 \text{ MPH}$$

JOB TMPH: 13.5 Tons x 16.9 MPH = 228 TMPH

CONCLUSION:

To avoid heat issues, tires must have a TMPH rating of 228 or higher.

If the tires on the machine are rated less than 22:

- Reduce speed
- Reduce load
- Change to tires with a higher TMPH rating

NOTE: Each tire position on the machine must be calculated and considered. Position with the highest average load should be used.

TON-MILES-PER-HOUR SUMMARY

The Ton-Miles-Per-Hour formula (average tire load multiplied by average tire speed), helps you achieve optimum performance from Goodyear earthmover tires. It helps you calculate the load-speed-time factor that's within tire temperature limits. Use the TMPH formula to avoid premature tire removal due to excessive heat.

All Goodyear earthmover tires have been assigned a TMPH limit. Earthmover haul jobs operate at various TMPH rates, depending on the load, distance and time involved in round trips. Thus, each job's haul rate must be determined to compare it with each tire's TMPH rate limit.

For haul lengths in excess of 20 miles one way, consult your Goodyear Representative.

TKPH (METRIC) = Average Load (Metric Tons) x Average Speed (Km/h)

When electronic vehicle monitors are available, Goodyear uses a four hour rolling average TMPH/TKPH to determine SITE requirements.

WORK CAPABILITY FACTOR

LOAD AND CARRY DOZER AND LOADERS

THE WCF FORMULA

Multiply the average tire load* times the Max. Average Speed Per Hour to determine the Work Capability Factor Rating.**

* Average Tire Load = (empty tire load in tons + loaded tire load in tons) ÷ 2

** Maximum Average Speed = round trip distance in miles x maximum number of cycles per hour of continuous "Load & Carry" operation.

Goodyear Dozer and Loader tires are designed for use in "Dig and Load" service and selected on a Tire & Rim Association 5 MPH (10 KPH) maximum speed basis. Tire heat build-up in this type of operation is not a factor.

With the advent of new earthmover operational techniques, loaders are increasingly being used as transport vehicles. When a loader is used to haul material distances greater than 50 feet (15 meters), the operation is classified as "Load and Carry." Since this type of service will involve speeds above 5 MPH (10 KPH) for considerable distances, tire heat build-up must be taken into consideration to insure optimum tire performance.

As with all earthmover tires used in transport service, tire heat build-up is a function of the amount of work the tire is doing.

The increased thickness and higher load carrying requirements of Dozer and Loader tires necessitates the use of a tire limitation system - the WORK CAPABILITY FACTOR SYSTEM.

The Work Capability Factor rating system provides the guide lines to select the correct Goodyear tire for the job requirement. Years of controlled testing and field studies have culminated in a valid and practical means of establishing capabilities of Dozer and loader tires when used in "Load and Carry" Service.

The factors of Load and Speed have long been used for evaluating the limitations of transport tires. For tires used in transport service on loaders, additional factors such as more stops, starts and turning must be considered. These additional operational factors produce higher stresses on the tire components, resulting in increased tire heat build-up.

The formula is figured by multiplying the AVERAGE ton load PER TIRE and the MAXIMUM AVERAGE speed of the machine PER HOUR.

Here is an example: First, determine the AVERAGE TIRE LOAD for each tire by adding the empty tire load to the loaded tire load, and dividing by 2.

NOTE: Average front tire loads are always greater for front end loaders than average rear tire loads. Use the highest front tire average load for the WCF calculation. Equipment specifications, or better yet, actual weights may be used.

$$\frac{12.9 \text{ tons empty} + 21.7 \text{ tons loaded}}{2} = 17.3 \text{ Tons Avg. Load}$$

$$\frac{11.7 \text{ metric tons empty} + 19.6 \text{ metric tons loaded}}{2} = 15.7 \text{ Metric Tons Avg. Load}$$

Then, determine the MAXIMUM AVERAGE machine speed: To find this figure, compute the round trip distance in miles, and multiply that number by the maximum number of cycles per hour of CONTINUOUS "Load and Carry" operations. Short periods of vehicle downtime should not be included in the average speed calculation due to the relatively slow static cooling rate of Dig and Load tires.

400 feet one way=800 feet round trip=0.152 Miles/Cycle

$$0.152 \frac{\text{Miles}}{\text{Cycle}} \times 24 \frac{\text{Cycles}}{\text{Hour}} = 3.6 \text{ MPH (Max. Avg.)}$$

125 meters one way=250 meters round trip=0.25 KM/Cycle

$$0.25 \frac{\text{Kilometers}}{\text{Cycle}} \times 24 \frac{\text{Cycles}}{\text{Hour}} = 6 \text{ KPH (Max. Avg.)}$$

Now you have both the Average Tire Load for this job and the Maximum Average machine speed.

WORK CAPABILITY FACTOR

LOAD AND CARRY DOZER AND LOADERS

To find the Work Capability Factor rating required for this job, multiply these two numbers:

$$17.3 \text{ tons} \times 3.6 \text{ mph} = 62.28 \text{ WCF}$$

$$(15.7 \text{ metric tons} \times 6 \text{ Kph} = 94.2 \text{ metric WCF})$$

To find the right tire for the job consult the published Work Capability Factors for haul lengths of less than 2000 feet (610 meters) one way that have been established for each size and type of Goodyear Dozer and Loader tire, and select the tire whose WCF rate meets or exceeds the Job WCF requirement. If you have a multiple choice of tires whose WCF rate is more than the job requires, always select the tire with the lowest rate which will meet the requirement.

The Work Capability Factor requirement figure may be predetermined for any "Load and Carry" job involving Dozer and Loader tires by using this formula. If the job requires a higher WCF rating than that of the tires you are now using, you should either (a) replace the tires with higher rated types, or (b) reduce either speed or load factors to bring the WCF rating within acceptable limits for the tires.

Obviously, at extreme loads and haul distance, the WCF formula will no longer apply. Vehicles with tires loaded at 15% above their rated capacity or used on hauls of more than 2,000 feet (610 meters) one way - cannot qualify for WCF calculations. For haul lengths in excess of 2,000 feet (610 meters) one way, consult your Goodyear representative.

The WCF formula helps you select the right Dozer and Loader tires for the job - before you buy. It's another customer service at Goodyear, producers of the industry's Work Capability Factor rated Dozer and Loader tires.

Example of WCF Application - for established job site planning a "Load & Carry" operation

1. Conditions:

$$\begin{array}{l} \text{Front Tire Loads - Empty} = 25,800\# \\ \text{Loaded} = 43,400\# \end{array} \quad \text{AVG} = 17.3 \text{ tons}$$

2. Tire on Loader: 35/65R33 (L-5) WCF = 80

3. Determination of Maximum Allowable Average Speed:

$$\frac{80 \text{ WCF}}{17.3 \text{ Tons}} = 4.6 \text{ MPH}$$

4. Determination of Maximum Number of Cycles per Hour:

$$4.6 \text{ MPH} = \frac{\text{Cycles}}{\text{Hour}} \times 800 \frac{\text{Feet}}{\text{Cycle}} \times 1 \frac{\text{Mile}}{5280 \text{ Feet}}$$

$$\frac{\text{Cycles}}{\text{Hour}} = \frac{4.6 \text{ MPH} \times 5280 \text{ Feet/Mi}}{800 \text{ feet/cycle}} = 30 \frac{\text{Cycles/Hour}}{\text{Maximum}}$$

Example of WCF Application (metric).

1. Conditions:

$$\begin{array}{l} \text{Front Tire Loads - Empty} = 11,700 \text{ Kg.} \\ \text{Loaded} = 19,600 \text{ Kg.} \end{array} \quad \text{AVG} = 15.7 \text{ metric tons}$$

2. Tire on Loader: 35/65R33 (L-5) WCF = 116 metric

3. Determination of Maximum Allowable Average Speed:

$$\frac{116 \text{ metric WCF}}{15.7 \text{ metric tons}} = 7.4 \text{ KPH}$$

4. Determination of Maximum Number of Cycles per Hour:

$$7.4 \text{ KPH} = \frac{\text{Cycles}}{\text{Hour}} \times 250 \frac{\text{Meters}}{\text{Cycle}} \times 1 \frac{\text{Kilometer}}{1000 \text{ Meters}}$$

$$\frac{\text{Cycles}}{\text{Hour}} = \frac{7.4 \text{ KPH} \times 1000 \text{ M/Km}}{250 \text{ M/Cycle}} = 30 \frac{\text{Cycles/Hour}}{\text{Maximum}}$$

MIXING OF BIAS AND RADIAL TIRES ON A VEHICLE

SAME AXLE on any vehicle - Bias and radial tires must not be mixed on the same axle of any vehicle (drive, steer or trail).

Haul Trucks - When mixing tire constructions, radial tires should be used only on the front/steer axle and bias tires should be used only on the rear/drive axle.

Loaders, Container Handlers, Reach Stackers, Forklifts - Bias tires can be used on one axle and radials on the other axle.

Graders - Bias or radial tires can be used on the front axle. Bias or radial tires can be used on the rear axles.

NOTE: The tandem axles must have tires of the same construction - all radial tires or all bias tires.

Articulated Dump Truck (ADT) - Do not mix bias and radial tires on an ADT. Radial tires are recommended.

Scrapers - Mixing of bias and radial tires is not recommended. Use only bias tires or only radial tires.

Mobile Cranes - Due to differences in cornering force characteristics and spring rates, the best tire and vehicle performance will be obtained by applying tires of the same size and construction (radial ply or bias ply) to all vehicle wheel positions. However, different tire constructions are permitted on the steer, drive, and trailer axles of two-axle, tandem, and multiple-axle combinations when the following rules are observed.

- Never mix different tire sizes or tire constructions on the same axle.
- If radials are mixed with bias tires, the best handling will be obtained with the bias tires on the steer axle.
- Bias or radial tires may be used on either axle of two-axle vehicles, providing the vehicle has dual rear wheels or is equipped with Super Single wide-base tires.
- Either bias or radial tires may be used on the steering axle of vehicles with three or more axles. Either all bias or all radial tires should be used on the nonsteering axles.
- Never mix bias and radial tires in a tandem or multiple axle combination.

Always check with the vehicle manufacturer before changing tire size or tire construction on any vehicle. Carefully evaluate performance changes caused by tire size or tire construction changes before putting the vehicle back into service.

Other vehicle types - Contact the vehicle and tire manufacturer for tire mixing options.

NOTE: Ton Mile Per Hour (TMPH) and Work Capability Factor (WCF) must be considered for proper fitment to all positions.

COMPARATIVE SIZE CHART

STAR RATING/PLY RATING EQUIVALENTS

Conventional		Wide Base		65 Series	
English	Metric	English	Metric	English	Metric
13.00	330	15.5	395	*	*
14.00	395	17.5	445	22	550
16.00	445	23.5	605	25	750
21.00	*	26.5	*	30	775
24.00	*	29.5	*	35	875
*	*	33.25	*	40	*
27.00	*	33.5	*	40	*
*	*	37.25	*	*	*
30.00	*	37.5	*	45	1150
*	*	41.25	*	*	*
33.00	*	41.5	*	*	*
36.00	*	45.5	*	50	1270
40.00	*	49.5	*	*	*

Service	Tire Size	Star Rating	Corresponding Ply Rating Eq.
Earthmover	12.00R24	***	Up to 30
	13.00R24	**	Up to 26
	14.00R24	***	Up to 32
	16.00R25	**	Up to 32
	18.00R25	**	Up to 36
	18.00R33	**	Up to 38
	21.00R33	**	Up to 44
	21.00R35	**	Up to 44
	24.00R35	**	Up to 48
	24.00R49	**	Up to 48
	27.00R49	**	Up to 54
	30.00R51	**	Up to 60
	33.00R51	**	Up to 66
	36.00R51	**	Up to 70
	37.00R57	**	Up to 78
	40.00R57	**	Up to 80
	17.5R25	**	Up to 24
		*	Up to 16
	20.5R25	**	Up to 28
		*	Up to 16
	23.5R25	**	Up to 30
		*	Up to 20
	26.5R25	**	Up to 34
29.5R25	**	Up to 24	
	*	Up to 38	
29.5R29	**	Up to 26	
33.25R29	**	Up to 38	
33.25R35	**	Up to 46	
37.25R35	**	Up to 46	
37.5R39	**	Up to 48	
40.5/75R39	**	Up to 48	
25/65R25	**	Up to 54	
30/65R25	**	Up to 32	
	**	Up to 34	

Service	Tire Size	Star Rating	Corresponding Ply Rating Eq.
Grader	13.00R24	*	Up to 14
	14.00R24	*	Up to 16
	16.00R24	*	Up to 18
Loader	14.00R24	***	Up to 28
		*	Up to 18
	15.5R25	*	Up to 14
	17.5R25	**	Up to 22
		*	Up to 16
	20.5R25	*	Up to 20
	23.5R25	*	Up to 24
	26.5R25	*	Up to 26
	29.5R25	*	Up to 28
	33.25R35	*	Up to 32
	37.25R35	*	Up to 36
	37.5R39	*	Up to 36
	22/65R25	*	Up to 24
	25/65R25	*	Up to 22
	30/65R25	*	Up to 26
35/65R33	**	Up to 42	
	*	Up to 30	
45/65R45	**	Up to 58	
	*	Up to 46	

Notes:
 (1) * = Not available
 (2) Tire widths are only listed for comparison

HISTORIC TIRE NOMENCLATURE

BY ALPHA NUMERIC NAMES, PREVIOUS NAMES AND INDUSTRY CODE

HAULAGE TIRES FOR TRUCKS AND SCRAPERS

ALPHA NUMERIC NAMES	PREVIOUS NAMES	INDUSTRY CODE
---------------------	----------------	---------------

BIAS CONSTRUCTION - CONVENTIONAL SIZES

HRR-1A	Hard Rock Rib	E-1
XDR-1A	Extra Duty Rib	E-1
SGL-2A	Earthmover Sure Grip	E-2
HRL-3A	Hard Rock Lug	E-3
HRL-3B	Hard Rock Lug 8	E-3
HRL-3C	Hard Rock Lug 8R	E-3
WRL-3A	Hard Rock Lug Xtra Wall	E-3
HRL-4A	Hard Rock Lug XT	E-4
HRL-4B	Hard Rock Lug XT-8	E-4
MRL-4B, F	Hard Rock Lug XT-8M	E-4
EAW-7A	Earthmover All Weather	E-7
SHY-7A	Semi Highway 5 Rib	E-7

BIAS CONSTRUCTION - WIDE BASE SIZES

SGL-2A	Sure Grip Lug	E-2
HRL-3A	Super Hard Rock Lug	E-3
HRL-3B	Super Hard Rock Lug 8	E-3
HRL-3F		E-3
EAW-7A	Earthmover All Weather	E-7

OTHER TIRES

ALPHA NUMERIC NAMES	PREVIOUS NAMES	INDUSTRY CODE
---------------------	----------------	---------------

CONVENTIONAL SIZES

SMC-1A	Smooth Compactor	C-1
RTS-1A	Trib Tow Service	
MC-1A	Mobile Crane Service	

SAND TIRES

ALPHA NUMERIC NAMES	PREVIOUS NAMES	INDUSTRY CODE
---------------------	----------------	---------------

BIAS CONSTRUCTION - CONVENTIONAL SIZES

SAW-7A	Sand All Weather	E-7
SRB-7A	Sand Rib	E-7
SRB-7A, 7B	Special Sand & Road Service	E-7

DOZER/LOADER TIRES FOR WORK MACHINES

ALPHA NUMERIC NAMES	PREVIOUS NAMES	INDUSTRY CODE
---------------------	----------------	---------------

BIAS CONSTRUCTION - WIDE BASE SIZES

SGL D/L-2A	Sure Grip Loader	L-2/G-2
SGL D/L-2A	Sure Grip Lug DL	L-2
ELV-3A		L-3
HRL D/L-3A	Super Hard Rock Loader	L-3/G-3
HRL D/L-3A	Super Hard Rock Lug DL	L-3
HRL D/L-3B	Super Hard Rock Lug 8 DL	L-3
HRL D/L-3C		L-3
HRL D/L-4A	Super Hard Rock Lug XT DL	L-4
HRL D/L-4G		L-4
HRL D/L-4/15C		L-4
HRL D/L-5A	Super Xtra Tread DL	L-5/G-5
HRL D/L-5A	Super Xtra Tread DL	L-5
HRL D/L-5B	Super Xtra Tread II DL	L-5

BIAS BELTED CONSTRUCTION - 65 ASPECT RATIO SIZES

NRL D/L-4A	NYLOSTEEL Xtra Tread DL	L-4
NRL D/L-5A	NYLOSTEEL Super Xtra Tread DL	L-5

GRADER TIRES

ALPHA NUMERIC NAMES	PREVIOUS NAMES	INDUSTRY CODE
---------------------	----------------	---------------

BIAS CONSTRUCTION - CONVENTIONAL SIZES

RBG-1A	Rib Grader	G-1
ASG-2A	All Service Grader	G-2
SGG-2A	Sure Grip Grader	G-2
SGL D/L-2A	Sure Grip Lug Grader	L-2/G-2
HRL D/L-3A	Super Hard Rock Lug Grader	L-3/G-3
RKG-3A	Rock Grader	G-3
RKG-3C	Rock Grader	G-3
SGG-4B		G-4
HRL D/L-5A	Super Xtra Tread DL	L-5/G-5
SMO D/L-5A, B	Smooth	L-5S/G-5S
AWG-1A	All Weather Grader	
SMG-1A	Smooth Grader	

SEVERE SERVICE- UNDERGROUND MINE AND QUARRY TIRES

ALPHA NUMERIC NAMES	PREVIOUS NAMES	INDUSTRY CODE
---------------------	----------------	---------------

BIAS CONSTRUCTION - CONVENTIONAL SIZES

HRL-3A	Hard Rock Lug UMS	L-3
AMS-4/5A	5:1 solid to void ratio	L-4
SMO-4B	Smooth	L-4S
AMS-5/8F	8:1 solid to void ratio	L-5
AMS-5/11F	11:1 solid to void ratio	L-5
AMS-5/15C	15:1 solid to void ratio	L-5
SMO-5A, B, C	Smooth	L-5S

BIAS CONSTRUCTION - WIDE BASE SIZES

SMO D/L-3A	Smooth	L-3S
SMO D/L-4A, B	Smooth	L-4S
AMS D/L-5/8H	8:1 solid to void ratio	L-5
AMS D/L-5/9A	9:1 solid to void ratio	L-5
AMS, DMS D/L-4/15C	15:1 solid to void ratio	L-4
AMS, DMS D/L-4/15C	15:1 solid to void ratio	L-5
DRL D/L-5A	Super Xtra Dual Tread	L-5
SMO D/L-5A, B	Smooth	L-5S/G-5S
SMO D/L-5A, B	Smooth	L-5S

BIAS BELTED CONSTRUCTION - 65 ASPECT RATIO SIZES

NRL, NDL D/L-4/15C	15:1 solid to void ratio	L-4
NSM D/L-4B	Smooth	L-4S
NRL, NDL D/L-5/15C	15:1 solid to void ratio	L-5
NSM D/L-5B	Smooth	L-5S

PORT & CONTAINER HANDLING TIRES

ALPHA NUMERIC NAMES	INDUSTRY LEVEL
---------------------	----------------

BIAS CONSTRUCTION

ELV-3A	100
ELV-4/5A	150
ELV-4B	150
ELV-4S	150
ELV-5A	250
ELV-5C	250
ELV-5D	250

CONVERSION FACTORS FOR DIMENSIONAL DATA

Dimensional Data	Units	Rounded off to	Conversion Factor
Minimum Dual Spacing	ins mm	to closest 0.1 unit to closest unit	(ins x 25.4)
Inflation	lbs/in ² bars	to closest 5 units to closest 1/4 bar	(lbs/in ² x 0.06895)
Load	lbs kgs	to closest 10 units to closest unit	(lbs x 0.4536)
Overall Width	ins mm	to closest 0.1 unit to closest unit	(ins x 25.4)
Overall Diameter	ins mm	to closest 0.1 unit to closest unit	(ins x 25.4)
Loaded Section + Gr.	ins mm	to closest 0.1 unit to closest unit	(ins x 25.4)
Static Loaded Radius	ins mm	to closest 0.1 unit to closest unit	(ins x 25.4)
Revolutions	rev/mi rev/km	to closest unit to closest unit	(rev/mi x 0.6214)
Gross Contact Area	ins ² cm ²	to closest unit to closest unit	(ins ² x 6.452)
Weight	lbs kg	to closest unit to closest unit	(lbs x 0.4536)
Speed	rmph kph	to closest unit to closest unit	(mph x 1.609)
Tread Depth	32nds/in mm	to closest unit to closest unit	(32nds x 0.7938)
Performance Capability	TMPH TKPH	to closest unit to closest unit	(TMPH x 1.458)
Capacity	YD ³ M ³	to closest 0.1 unit to closest unit	(YD ³ x 0.76456)

TIRE DIMENSIONS

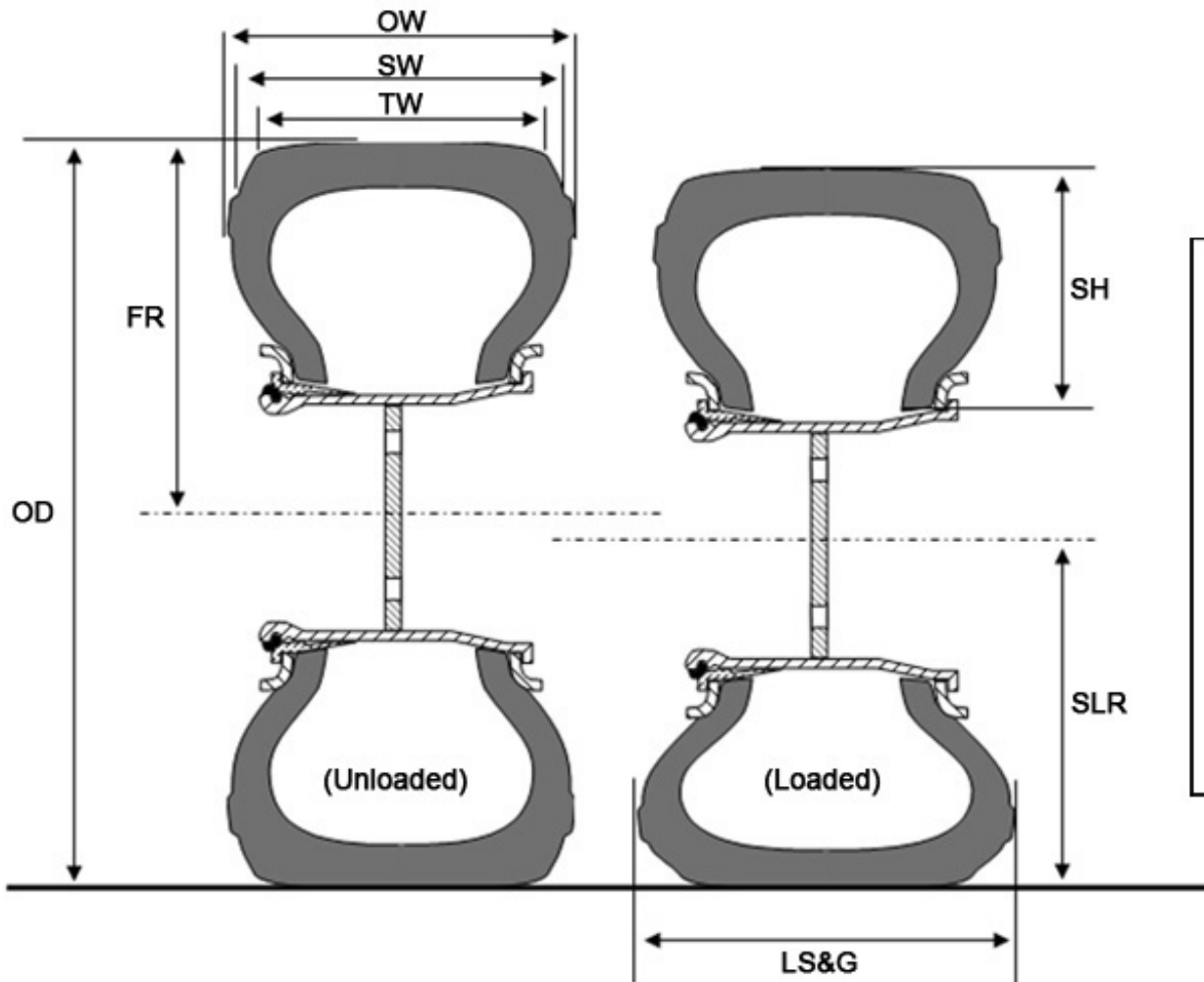

(OW)	Overall Width
(SW)	Section Width
(TW)	Tread Width
(SH)	Section Height
(FR)	Free Radius
(OD)	Overall Diameter
(SLR)	Static Loaded Radius
(LS&G)	Loaded Section & Growth

Size Definitions (examples)

Listed here are examples of some of the popular size designations for earthmover tires. With each size is an explanation of what each component of the size describes:

18.00 Section width in inches	R R (Radial), - (Bias)	25 Rim diameter in inches	Narrow Base	750 Section width in mm	/65 Aspect ratio	R R (Radial), - (Bias)	25 Rim diameter in inches	Low Aspect
23.5 Section width in mm	R R (Radial), - (Bias)	25 Rim diameter in inches	Wide Base	505 Section width in mm	/95 Aspect ratio	R R (Radial), - (Bias)	25 Rim diameter in inches	Millimetric

EXPLANATION OF HEADINGS FOR DIMENSIONAL DATA PAGES

Type	Goodyear Sales Name
IND Code	Industry Code - A code which indicates the type of service for the tire. Use of this code allows for comparisons between the competing brands of tires.
Current in Line Location	Regions of the world where the tire is produced or inventoried and available for sale.
Rim Width and Flange	Width of the rim base in inches and height of the flange for the design rim. <i>See rim section for any alternate approved rims.</i>
Min. Dual Spacing	Recommended minimum distance between the tire center lines for dual applications.
Overall Width	Measurement of the new tire when inflated and mounted on the recommended rim.
Overall Diameter	Measurement of the new tire when inflated and mounted on the recommended rim.
Load Sect & Growth	Loaded Section & Growth - The maximum width of a cross-sectional view of a loaded tire including the effect of the carcass stretch over time.
Static Load Rad	Static Loaded Radius - Distance from center of wheel to ground on a vehicle which has rated load, rated inflation, and is not in motion.
Revol Per Mi (KM)	Revolutions per mile (kilometer) - the number of revolutions that the mounted tire will make in one mile (kilometer), at rated load and inflation.
Gross Contact Area	The surface of the tire in contact with the road surface at any given load and inflation pressure.
Tire Volume	<p>Total internal Tire Volume. If liquid ballast is desired, 3/4 fill can be calculated as follows:</p> <p>Water Only: Vol x 0.75 CaCl₂ is used to prevent freezing and add additional weight. Typically it is added at a 3.5 lbs./gal. ratio. Volume of a gal. of water = 231 cu. in. Total Gals available x 231 = Volume in cu. in. Swell Factor for 3.5 lbs CaCl₂ = 38.6 cu. in. Vol of 1 ga. H₂O + 3.5 lbs CaCl₂ = 269.6 cu. in.</p> $\frac{3/4 \text{ total cu. in. available}}{269.6} = \text{Gal. Water Used}$ <p>Weight can be found by:</p> <p>Weight of Water = Gal. x 8.35 <u>+ Weight of CaCl₂ = Gal. x 3.5</u> = Ballast Weight</p>
Tread Depth	The depth in thirty-seconds of an inch or mm measured from the tread surface to the bottom of the tread grooves.
Performance Capability	TMPH / TKPH ^WCF <i>See Pages 8-10 For Complete Explanation</i>

CONVENTIONAL SIZE

DIMENSIONAL DATA

BIAS



SMC-1A

SRB-7A

Size	Type	Ind Code	Current In Line Location	Rim Width & Flange	Min. Dual Spacing in mm	INFLATED DIMENSIONS				LOADED DIMENSIONS				Revol Per mi km	Gross Contact Area		Tire Volume		Tread Depth 1/32 in mm	PERFORMANCE CAPABILITY												
						Overall Width in mm		Overall Diameter in mm		Load Sect & Growth in mm		Static Load Rad in mm			in ²	cm ²	gal	ltrs		2S		4S		6S								
						in	mm	in	mm	in	mm	in	mm	mi	km					in	mm	in	mm	in	mm	in	mm	in	mm	in	mm	
7.50-15NHS	* OLY (SMC) #	C-1	A	6.5		8.7	221	29.7	754	9.5	241	13.6	345	705	438	66.0	426															
	* SMC-1A	C-1		6.50T		8.4	213	31.0	787	9.4	239	14.2	361	700	435	64.0	413															
9.00-15	SRB-7A	E-7		5 1/2K		9.6	244	32.5	826	10.7	272	14.6	371	688	428	48.0	310			7	6											
11.00-16	SRB-7A	E-7		6.50H		10.9	277	35.6	904	12.2	310	16.6	422	598	372	67.0	432	28.0	104.0	9	7											
16.00-16	SRB-7A	E-7		6.50H		13.3	338	42.5	1080	15.7	399	17.9	455	531	330	157.0	1013			10	8											
6.00-16	SMC-1A	C-1				6.8	173	28.7	729	7.2	183	13.5	343	724	450	41.0	264															
7.50-16NHS	OLY (SMC) #	C-1	A	6.5		8.7	221	31.1	790	9.5	241	14.3	363	674	419	70.0	451															

See Wide Base Section for 80 aspect ratio tires (e.g. 59/80R63)

Sizes in bold type can be obtained in locations in bold. Extended lead time may be needed in other locations.

Legend	N = North America	E = Europe / Africa / Mid East	# = Estimated Data	^ = Work Capability Factor
	L = Latin America	A = Asia / Australia	* = Tube Type Tire	

LOAD LIMITS AT COLD INFLATION PRESSURES

5 MPH (10 KM/H) MAXIMUM SPEED COMPACTOR SERVICE

	PSI	45	50	55	60	65	70	75	80	85	90	95	100	105	110	125
BIAS	KPA	325	350	400	425	450	475	525	550	575	625	650	675	725	750	850
7.50-15NHS	LBS	3460	3700	3900(6)	4100	4300	4500	4680	4860	5040	5200(10)	5380	5540	5700	5860(12)	
	KG	1570	1680	1770(6)	1860	1950	2040	2120	2200	2290	2360(10)	2440	2510	2590	2650(12)	
6.00-16	LBS	2300	2450	2600	2750	2900	3000	3100	3200(6)	3370	3500	3600	3700	3800	3820(8)	4200(10)
	KG	1040	1110	1180	1250	1320	1360	1410	1450(6)	1530	1590	1630	1680	1720	1730(8)	1910(10)
BIAS	PSI	45	50	55	60	65	70	75	80	85	90	95	100	105	110	
	KPA	325	350	400	425	450	475	525	550	575	625	650	675	725	750	
7.50-16NHS	LBS	3620	3860	4080(6)	4280	4500	4680(8)	4880	5080	5260	5440(10)	5600	5780	5940	6100(12)	
	KG	1640	1750	1850(6)	1940	2040	2120(8)	2210	2300	2390	2470(10)	2540	2620	2690	2770(12)	

5 MPH (10 KM/H) MAXIMUM SPEED OFF-THE-ROAD SAND SERVICE

	PSI	11	15	18	22	25	29	33	36
BIAS	KPA	75	100	125	150	175	200	225	250
9.00-15	LBS	1820	2150	2470	2680	3000	3200	3420	3640
	KG	825	975	1120	1215	1360	1450	1550	1650
11.00-16	LBS	2270	2680	3090	3420	3750	4080	4300	4670
	KG	1030	1215	1400	1550	1700	1850	1950	2120
16.00-16	LBS	4410	5360	6010	6780	7390	8050	8540	9090
	KG	2000	2430	2725	3075	3350	3650	3875	4125

30 MPH (50 KM/H) MAXIMUM SPEED OFF-THE-ROAD SAND SERVICE

	PSI	11	15	18	22	25	29	33	36
BIAS	KPA	75	100	125	150	175	200	225	250
9.00-15	LBS	1230	1480	1650	1870	2040	2200	2340	2470
	KG	560	670	750	850	925	1000	1060	1120
11.00-16	LBS	1570	1870	2090	2340	2600	2760	3000	3310
	KG	710	850	950	1060	1180	1250	1360	1500
16.00-16	LBS	3090	3640	4080	4540	5070	5360	5840	6170
	KG	1400	1650	1850	2060	2300	2430	2650	2800

40 MPH (65 KM/H) MAXIMUM SPEED OFF-THE-ROAD SAND SERVICE

	PSI	11	15	18	22	25	29	33	36
BIAS	KPA	75	100	125	150	175	200	225	250
9.00-15	LBS	1050	1230	1430	1570	1710	1870	1980	2090
	KG	475	560	650	710	775	850	900	950
11.00-16	LBS	1320	1570	1760	1980	2150	2340	2540	2680
	KG	600	710	800	900	975	1060	1150	1215
16.00-16	LBS	2600	3090	3530	3860	4300	4540	4940	5200
	KG	1180	1400	1600	1750	1950	2060	2240	2360

Legend

▲ Permafoam inflation or special rim required

CONVENTIONAL SIZE

DIMENSIONAL DATA

BIAS



American Miner RS American Skid Steer American Skid Steer Plus SRB-7A

Size	Type	Ind Code	Current In Line Location	Rim Width & Flange	Min. Dual Spacing in mm	INFLATED DIMENSIONS				LOADED DIMENSIONS				Revol Per mi km	Gross Contact Area in ² cm ²	Tire Volume gal ltrs	Tread Depth 1/32 in mm	PERFORMANCE CAPABILITY					
						Overall Width in mm		Overall Diameter in mm		Load Sect & Growth in mm		Static Load Rad in mm						2S tmph tkph		4S tmph tkph		6S tmph tkph	
9.00-16	SRB-7A	E-7		6.50H		10.2	259	35.0	889	11.1	282	16.0	406	620	385	56.0	361	8	6				
10-16.5NHS	American Skid Steer	SS	N L E A	8.25		10.7	272	30.6	777									32	25				
	American Skid Steer Plus	SS	N L E A	8.25		10.5	267	31.0	787									30	24				
10.00-16.5NHS	American Miner RS	IND-3	N	7.25x16.5		10.7	270	30.6	776									32	25.4				
12-16.5NHS	American Skid Steer	SS	N L E A	9.75		13.0	330	32.9	836									40	32				
	American Skid Steer Plus	SS	N L E A	9.75		12.5	318	33.0	838									32	25				
12.00-16.5NHS	American Miner RS	IND-3	N	9.75x16.5		13.0	330	32.9	835									40	31.7				
14-17.5NHS	American Skid Steer	SS	N L E A	10.5		13.4	339	36.3	921									25	20				

See Wide Base Section for 80 aspect ratio tires (e.g. 59/80R63)

Sizes in bold type can be obtained in locations in bold. Extended lead time may be needed in other locations.

Legend	N = North America	E = Europe / Africa / Mid East	# = Estimated Data	^ = Work Capability Factor
	L = Latin America	A = Asia / Australia	* = Tube Type Tire	

LOAD LIMITS AT COLD INFLATION PRESSURES

5 MPH (10 KM/H) MAXIMUM SPEED OFF-THE-ROAD SAND SERVICE

	PSI	11	15	18	22	25	29	33	36
BIAS	KPA	75	100	125	150	175	200	225	250
9.00-16	LBS	1870	2200	2540	2830	3090	3310	3530	3860
	KG	850	1000	1150	1285	1400	1500	1600	1750

5 MPH (10 KM/H) 5mph (10km/hr) Construction Equipment Service

	PSI	30	35	40	45	50	55	60	65	75
BIAS	KPA	210	240	280	310	340	380	410	450	520
10-16.5NHS	LBS	2760(4)	3020	3260	3500(6)	3720	3930	4140(8)	4340	4710(10)
	KG	1250(4)	1370	1480	1590(6)	1685	1785	1880(8)	1970	2135(10)
BIAS	PSI	30	35	40	45	50	55	60	65	80
	KPA	210	240	280	310	340	380	410	450	550
12-16.5NHS	LBS	3560	3900	4220(6)	4520	4810(8)	5080	5340	5600(10)	6320(12)
	KG	1615	1770	1915(6)	2050	2180(8)	2305	2420	2540(10)	2865(12)
14-17.5NHS	LBS	4820(6)	5260	5700(8)	6100	6500	6850(10)	7220	7560(12)	8540(14)
	KG	2185(6)	2385	2585(8)	2765	2950	3105(10)	3275	3430(12)	3875(14)

30 MPH (50 KM/H) MAXIMUM SPEED OFF-THE-ROAD SAND SERVICE

	PSI	11	15	18	22	25	29	33	36
BIAS	KPA	75	100	125	150	175	200	225	250
9.00-16	LBS	1280	1520	1760	1930	2090	2270	2470	2600
	KG	580	690	800	875	950	1030	1120	1180

40 MPH (65 KM/H) MAXIMUM SPEED OFF-THE-ROAD SAND SERVICE

	PSI	11	15	18	22	25	29	33	36
BIAS	KPA	75	100	125	150	175	200	225	250
9.00-16	LBS	1100	1280	1480	1650	1760	1930	2090	2200
	KG	500	580	670	750	800	875	950	1000

Legend

▲ Permafoam inflation or special rim required

CONVENTIONAL SIZE

DIMENSIONAL DATA

BIAS



American Miner SLHD SMC-1A HR Lug

Size	Type	Ind Code	Current In Line Location	Rim Width & Flange	Min. Dual Spacing in mm	INFLATED DIMENSIONS		LOADED DIMENSIONS		Revol Per mi km	Gross Contact Area in ² cm ²	Tire Volume gal ltrs	Tread Depth 1/32 in mm	PERFORMANCE CAPABILITY			
						Overall Width in mm	Overall Diameter in mm	Load Sect & Growth in mm	Static Load Rad in mm					2S tmph tkph	4S tmph tkph	6S tmph tkph	
10.00-20NHS	American Miner SLHD	IND-3	N	7.5x20		42.9	1089		11.5	292			32	25			
10.00-20ML	* HR Lug	E-3		7.5	13.5 343	10.9	277	42.7 1085	11.8 300	19.9 506	498 309	74.0 477	27	21			
11.00-20NHS	* HR LUG WC	E-3		8.5	15.0 381	12.2	310	43.2 1097	13.3 338	20.4 518	486 302	86.0 555	28	22			
	* SMC-1A	C-1		8.5	15.0 381	11.7	298	42.3 1074	12.7 322	20.0 508	492 306	105.0 677	30.3	114.7	22	17	

See Wide Base Section for 80 aspect ratio tires (e.g. 59/80R63)

Sizes in bold type can be obtained in locations in bold. Extended lead time may be needed in other locations.

Legend	N = North America	E = Europe / Africa / Mid East	# = Estimated Data	^ = Work Capability Factor
	L = Latin America	A = Asia / Australia	* = Tube Type Tire	

LOAD LIMITS AT COLD INFLATION PRESSURES

5 MPH (10 KM/H) MAXIMUM SPEED OFF-THE-ROAD SLOW SPEED SERVICE

	PSI	73	76	80	83	87	91	94	98	102	105	109
BIAS	KPA	500	525	550	575	600	625	650	675	700	725	750
10.00-20ML	LBS	8050	8250	8550(12)	8800	8800	9100	9350(14)	9650	9900	9900	10200(16)▲
	KG	3650	3750	3875(12)	4000	4000	4125	4250(14)	4375	4500	4500	4625(16)▲
BIAS	PSI	73	76	80	83	87	91	94	98	102	105	
	KPA	500	525	550	575	600	625	650	675	700	725	
11.00-20NHS	LBS	8550	8800	9100(12)	9350	9350	9650	9900(14)	10200	10470	10750(16)	
	KG	3875	4000	4125(12)	4250	4250	4375	4500(14)	4625	4750	4875(16)	

30 MPH (50 KM/H) MAXIMUM SPEED OFF-THE-ROAD HAULAGE SERVICE

	PSI	40	44	47	51	54	58	62	65	69	73
BIAS	KPA	275	300	325	350	375	400	425	450	475	500
10.00-20ML	LBS	3860	4080(10)	4300	4400	4680(12)	4800	4940	5200(14)	5360	5520(16)
	KG	1750	1850(10)	1950	2000	2120(12)	2180	2240	2360(14)	2430	2500(16)

55 MPH (90 KM/H) MAXIMUM SPEED OFF-THE-ROAD MINING AND LOGGING SERVICE

	PSI	45	50	55	60	65	70	75	80	85	90
BIAS	KPA	310	340	380	410	450	480	520	550	590	620
10.00-20ML	LBS	3530	3760	3970	4180	4380	4580	4805(F)	4950	5120	5355(G)
	KG	1600	1710	1800	1900	1990	2080	2180(F)	2250	2320	2430(G)

Legend

▲ Permafoam inflation or special rim required

CONVENTIONAL SIZE

DIMENSIONAL DATA

RADIAL

BIAS



EV-5S RL-5K (24/24) RL-5K (08/08) RL-5K (12/12) American Miner MS SMO-5B HRL-3A SGG-2A

Size	Type	Ind Code	Current In Line Location	Rim Width & Flange	Min. Dual Spacing in mm	INFLATED DIMENSIONS		LOADED DIMENSIONS		Revol Per mi km	Gross Contact Area in ² cm ²	Tire Volume gal ltrs	Tread Depth 1/32 in mm	PERFORMANCE CAPABILITY			
						Overall Width in mm	Overall Diameter in mm	Load Sect & Growth in mm	Static Load Rad in mm					2S tmph tkph	4S tmph tkph	6S tmph tkph	
12.00-20NHS	American Miner MS	IND-3	N	8.2x20		12.0	304	44.2	1122				28	22			
	* SMO-5B	L-5S	E	8.5	15.1 384	13.2	335	46.3	1176				80	64			
12.00-20ML	HRL-3A	E-3	N L E	8.5	15.6 396	13.0	330	45.3	1151	14.4 366	20.8 528	457 284	125.0 807	40.0 151.4	28	22	
12.00R20NHS	EV-5S	IND-5S		8.5	15.6 396	12.3	312	46.6	1184	13.7 348	20.8 528	451 280	165.0 1067	32.0 121.0	78	62	
	RL-5K (08/08)	L-5	N	8.5	15.6 396	12.3	312	46.6	1184	13.7 348	20.8 528	451 280	165.0 1067		78	62	
	RL-5K (12/12)	L-5	N	8.5	15.6 396	12.3	312	46.6	1184	13.7 348	20.8 528	451 280	165.0 1067		78	62	
	RL-5K (24/24)	L-5	N	8.5	15.6 396	12.3	312	46.6	1184	13.7 348	20.8 528	451 280	165.0 1067		78	62	
13.00-20TG	* SGG-2A	G-2	N	8.00TG		13.7	348	46.7	1186	15.6 396	21.2 539	448 278	149.0 961	46.0 173.0	30	24	

See Wide Base Section for 80 aspect ratio tires (e.g. 59/80R63)

Sizes in bold type can be obtained in locations in bold. Extended lead time may be needed in other locations.

Legend	N = North America	E = Europe / Africa / Mid East	# = Estimated Data	^ = Work Capability Factor
	L = Latin America	A = Asia / Australia	* = Tube Type Tire	

LOAD LIMITS AT COLD INFLATION PRESSURES

5 MPH (10 KM/H) MAXIMUM SPEED OFF-THE-ROAD SLOW SPEED SERVICE

	PSI	73	76	80	83	87	91	94	98	102	105	109	112	116	120	149
BIAS	KPA	500	525	550	575	600	625	650	675	700	725	750	775	800	825	1025
12.00-20NHS	LBS	9900(12)	10200	10500	10700(14)	11000	11400	11700	12000(16)	12300	12300	12800▲	12800▲	13200▲	13600(20)▲	15200(28)▲
	KG	4500(12)	4625	4750	4875(14)	5000	5150	5300	5450(16)	5600	5600	5800▲	5800▲	6000▲	6150(20)▲	6900(28)▲
RADIAL	PSI	80	98	102	105	109	112	116	120	123	127	131	134	138	141	145
	KPA	550	675	700	725	750	775	800	825	850	875	900	925	950	975	1000
12.00R20NHS	LBS	9900*	11700	12000	12300	12800	12800	13200	13600**	13900	13900	14300	14800	15200***	15200	15700
	KG	4500*	5300	5450	5600	5800	5800	6000	6150**	6300	6300	6500	6700	6900***	6900	7100
BIAS	PSI	44	47	51	54											
	KPA	300	325	350	375											
13.00-20TG	LBS	8550	8800	9350	9650(10)											
	KG	3875	4000	4250	4375(10)											

25 MPH (40 KM/H) MAXIMUM SPEED OFF-THE-ROAD TRACTOR AND GRADER SERVICE

	PSI	22	25	29	33
BIAS	KPA	150	175	200	225
13.00-20TG	LBS	3740	4080	4400	4680(10)
	KG	1700	1850	2000	2120(10)

30 MPH (50 KM/H) MAXIMUM SPEED OFF-THE-ROAD HAULAGE SERVICE

	PSI	40	44	47	51	54	58	62	65
BIAS	KPA	275	300	325	350	375	400	425	450
12.00-20NHS	LBS	4800	5080	5360	5520	5840(14)	6000	6150	6400(16)
	KG	2180	2300	2430	2500	2650(14)	2725	2800	2900(16)

30 MPH (50 KM/H) MAXIMUM SPEED OFF-THE-ROAD HAULAGE SERVICE

	PSI	40	44	47	51	54	58	62	65
BIAS	KPA	275	300	325	350	375	400	425	450
12.00-20ML	LBS	4800	5080	5360	5520	5840(G)	6000	6150	6400(H)
	KG	2180	2300	2430	2500	2650(G)	2725	2800	2900(H)

50 MPH (80 KM/H) MAXIMUM SPEED OFF-THE-ROAD MINING AND LOGGING SERVICE

	PSI	55	60	65	70	75	80	85	90	95
BIAS	KPA	380	410	450	480	520	550	590	620	660
12.00-20ML	LBS	4930	5190	5440	5680	5910	6175(G)	6360	6580	6940(H)
	KG	2240	2350	2470	2580	2680	2800(G)	2880	2980	3150(H)

Legend

▲ Permafoam inflation or special rim required

CONVENTIONAL SIZE

DIMENSIONAL DATA



Size	Type	Ind Code	Current In Line Location	Rim Width & Flange	Min. Dual Spacing in mm	INFLATED DIMENSIONS		LOADED DIMENSIONS		Revol Per mi km	Gross Contact Area		Tire Volume		Tread Depth		PERFORMANCE CAPABILITY								
						Overall Width in mm	Overall Diameter in mm	Load Sect & Growth in mm	Static Load Rad in mm		in ²	cm ²	gal	ltrs	1/32 in	mm	2S tmph tkph	4S tmph tkph	6S tmph tkph						
14.00-20	* SRB-7A	E-7		10.00W		15.6	396	47.5	1207	17.7	450	21.4	544	444	276	131.0	845	58.0	220.0	10	8				
14.00-20NHS	* ELV-3A	IND-3		10.00W	17.7 450																				
	* HRL-3A	E-3		10.00W	17.7 450	14.8	376	49.1	1247	16.1	409	22.4	569	425	264	150.0	968			33	26				
14.00-20ML	* EM-SG	E-2		10.00W	17.7 450	15.0	381	48.6	1234	16.6	422	22.2	564	428	266	167.0	1078			32	25				
	* SGL-2A	E-2		10.00W	17.7 450	15.0	381	48.6	1234	16.6	422	22.2	564	428	266	167.0	1078			32	25				
14.00R20	AT-2A	E-3	N	A	10.00W	17.7	450	15.1	384	49.2	1250	16.1	409	22.5	572	422	262	128.0	826	63.7	241.1	30	24		
	AT-2A	E-3			10.00-1.5	17.7	450	15.2	386	49.2	1250	16.8	427	22.4	569	427	265	160.0	1032	63.7	241.1	30	24		
	G286*				10.00W	17.7	450	15.0	381	48.4	1229	16.7	424	22.2	563	434	269	140.0	903	62.7	237.0	19	15		

See Wide Base Section for 80 aspect ratio tires (e.g. 59/80R63)

Sizes in bold type can be obtained in locations in bold. Extended lead time may be needed in other locations.

Legend	N = North America	E = Europe / Africa / Mid East	# = Estimated Data	^ = Work Capability Factor
	L = Latin America	A = Asia / Australia	* = Tube Type Tire	

LOAD LIMITS AT COLD INFLATION PRESSURES

5 MPH (10 KM/H) MAXIMUM SPEED OFF-THE-ROAD SLOW SPEED SERVICE

		69	73	76	80	83	87	91	94	98	102	105	109	123
BIAS	PSI	69	73	76	80	83	87	91	94	98	102	105	109	123
	KPA	475	500	525	550	575	600	625	650	675	700	725	750	850
14.00-20NHS	LBS	13200	13900	14300	14800	14800	15200	15700(18)	16100	16500	16500(20)	17100	17600▲	18700(24)▲
	KG	6000	6300	6500	6700	6700	6900	7100(18)	7300	7500	7500(20)	7750	8000▲	8500(24)▲
RADIAL	PSI	76	80	83	87	91	94	98	102	105	109	112	116	120
	KPA	525	550	575	600	625	650	675	700	725	750	775	800	825
14.00R20	LBS	13200	13600*	14300	14800	15200	15700	16100	16500	17100	17100	17600	18200	18700**
	KG	6000	6150*	6500	6700	6900	7100	7300	7500	7750	7750	8000	8250	8500**

30 MPH (50 KM/H) MAXIMUM SPEED OFF-THE-ROAD HAULAGE SERVICE

		40	44	47	51	54	58	62	65	69	73	76	80
BIAS	PSI	40	44	47	51	54	58	62	65	69	73	76	80
	KPA	275	300	325	350	375	400	425	450	475	500	525	550
14.00-20NHS	LBS	6600(12)	6950	7400	7600	8050(16)	8250	8550	8800	9100(20)	9370	9650	9920(24)
	KG	3000(12)	3150	3350	3450	3650(16)	3750	3875	4000	4125(20)	4250	4375	4500(24)
RADIAL	PSI	65	69	73	76	80	83	87	91	94	98	102	
	KPA	450	475	500	525	550	575	600	625	650	675	700	
14.00R20	LBS	7850	8250*	8550	8800	9100	9350	9650	10200	10500	10700	11000**	
	KG	3550	3750*	3875	4000	4125	4250	4375	4625	4750	4875	5000**	

40 MPH (65 KM/H) MAXIMUM SPEED OFF-THE-ROAD SAND SERVICE

		11	15	18	22	25	29	33	36
BIAS	PSI	11	15	18	22	25	29	33	36
	KPA	75	100	125	150	175	200	225	250
14.00-20	LBS	2600	3090	3530	3970	4300	4670(10)	4940	5360(12)
	KG	1180	1400	1600	1800	1950	2120(10)	2240	2430(12)

50 MPH (80 KM/H) MAXIMUM SPEED OFF-THE-ROAD MINING AND LOGGING SERVICE

		40	45	50	55	60	65	70	75	80	85	90	95	100
BIAS	PSI	40	45	50	55	60	65	70	75	80	85	90	95	100
	KPA	275	310	345	380	415	450	485	515	550	585	620	655	690
14.00-20ML	LBS	5620	6020	6400	6770(G)	7120	7470	7800(H)	8120	8430	8740(J)	9040	9320	9610(L)
	KG	2575	2725	2900	3075(G)	3250	3350	3550(H)	3650	3875	4000(J)	4125	4250	4375(L)

55 MPH (90 KM/H) MAXIMUM SPEED SERVICE

		55	60	65	70	75	80	85	90	95	100	105	110	115
RADIAL	PSI	55	60	65	70	75	80	85	90	95	100	105	110	115
	KPA	375	400	450	475	525	550	575	625	650	700	725	750	800
14.00R20	LBS	6410	6860	7300	7720(G)	8120	8510	8890(H)	9260	9610	9960(J)	10300	10620	10960(L)
	KG	2900	3100	3300	3500(G)	3675	3850	4025(H)	4200	4350	4525(J)	4675	4825	4975(L)

Legend

▲ Permafoam inflation or special rim required

CONVENTIONAL SIZE

DIMENSIONAL DATA



Size	Type	Ind Code	Current In Line Location	Rim Width & Flange	Min. Dual Spacing in mm	INFLATED DIMENSIONS				LOADED DIMENSIONS				Revol Per mi km	Gross Contact Area in ² cm ²	Tire Volume gal ltrs	Tread Depth 1/32 in mm	PERFORMANCE CAPABILITY					
						Overall Width in mm		Overall Diameter in mm		Load Sect & Growth in mm		Static Load Rad in mm						2S tmph tkph		4S tmph tkph		6S tmph tkph	
16.00-20	* SRB-7A	E-7		10.00W	20.2 513	17.0 432	52.1 1323	19.3 490	23.0 584	413 257	208.0 1342		17 13										
16.00R20	AT-2A	E-3	N	10.00W	20.2 513	17.1 434	52.1 1323	18.9 480	23.7 602	403 250	195.0 1258	80.5 304.6	33 26										
	AT-3A	E-3	N	10.00W	20.2 513	17.3 439	51.7 1313	19.2 487	23.4 594	406 252	192.0 1240	79.0 299.0	33 26										
	AT-3A	L-3		10.00W	20.2 513	17.3 439	51.7 1313	19.2 487	23.4 594	406 252	192.0 1240	79.0 299.0	33 26										
	GP-AT #	E-3T		10.00W	20.2 513	17.1 434	51.8 1316	18.9 480	22.9 582	406 252	193.0 1243	79.0 299.0	33 26										

See Wide Base Section for 80 aspect ratio tires (e.g. 59/80R63)

Sizes in bold type can be obtained in locations in bold. Extended lead time may be needed in other locations.

Legend	N = North America	E = Europe / Africa / Mid East	# = Estimated Data	^ = Work Capability Factor
	L = Latin America	A = Asia / Australia	* = Tube Type Tire	

LOAD LIMITS AT COLD INFLATION PRESSURES

5 MPH (10 KM/H) MAXIMUM SPEED OFF-THE-ROAD SAND SERVICE

	PSI	11	15	18	22	25	29	33	36
BIAS	KPA	75	100	125	150	175	200	225	250
16.00-20	LBS	6010	7170	8050	9090	9920	10750	11350	12350
	KG	2725	3250	3650	4125	4500	4875	5150	5600

5 MPH (10 KM/H) MAXIMUM SPEED OFF-THE-ROAD SLOW SPEED SERVICE

	PSI	76	80	83	87	91	94	98	102	105	109	112	116	120
RADIAL	KPA	525	550	575	600	625	650	675	700	725	750	775	800	825
16.00R20	LBS	17600	18200*	18700	19300	19800	20400	21500	22000	22700	22700	23400	24000	24700**
	KG	8000	8250*	8500	8750	9000	9250	9750	10000	10300	10300	10600	10900	11200**

30 MPH (50 KM/H) MAXIMUM SPEED OFF-THE-ROAD HAULAGE SERVICE

	PSI	65	69	73	76	80	83	87	91	94	98	102
RADIAL	KPA	450	475	500	525	550	575	600	625	650	675	700
16.00R20	LBS	10500	11000*	11400	11700	12000	12300	12800	13200	13900	14300	14800**
	KG	4750	5000*	5150	5300	5450	5600	5800	6000	6300	6500	6700**

30 MPH (50 KM/H) MAXIMUM SPEED OFF-THE-ROAD SAND SERVICE

	PSI	11	15	18	22	25	29	33	36
BIAS	KPA	75	100	125	150	175	200	225	250
16.00-20	LBS	4080	4940	5510	6170	6780	7380	7830	8270
	KG	1850	2240	2500	2800	3075	3350	3550	3750

40 MPH (65 KM/H) MAXIMUM SPEED OFF-THE-ROAD SAND SERVICE

	PSI	11	15	18	22	25	29	33	36
BIAS	KPA	75	100	125	150	175	200	225	250
16.00-20	LBS	3530	4080	4670	5200	5680	6170	6610	7170
	KG	1600	1850	2120	2360	2575	2800	3000	3250

55 MPH (90 KM/H) MAXIMUM SPEED SERVICE

	PSI	55	60	65	70	75	80	85	90	95	100	105	110
RADIAL	KPA	375	400	450	475	525	550	575	625	650	700	725	750
16.00R20	LBS	8770	9390	9990	10560	11110	11650	12160	12660	13150	13630(L)	14090	14540(M)
	KG	3975	4250	4525	4800	5050	5275	5525	5750	5975	6175(L)	6400	6600(M)

Legend

▲ Permafoam inflation or special rim required

CONVENTIONAL SIZE

DIMENSIONAL DATA

BIAS



SMO-5B SRB-7A HRL-3A

Size	Type	Ind Code	Current In Line Location	Rim Width & Flange	Min. Dual Spacing in mm	INFLATED DIMENSIONS				LOADED DIMENSIONS				Revol Per mi km	Gross Contact Area in ² cm ²	Tire Volume gal ltrs	Tread Depth 1/32 in mm	PERFORMANCE CAPABILITY					
						Overall Width in mm		Overall Diameter in mm		Load Sect & Growth in mm		Static Load Rad in mm						2S tmph tkph		4S tmph tkph		6S tmph tkph	
7.50-20	* Smo Crawl			6.00T	10.8 274	8.4 213	37.1 941	9.2 234	17.1 434	559 347	46.0 297			21 17									
9.00-20ML	* HRL-3A	E-3	N L	7.00	12.7 333	10.3 262	40.8 1036	11.5 292	19.2 488	517 321	72.0 465			26 21									
9.50-20NHS	* SMO-5B	L-5S	L A	7.5	13.4 340	11.2 283	41.4 1052	12.2 310	19.1 485	498 309	105.0 677			72 57									
24-20.5	SRB-7A	E-7		18.00DC		24.2 615	53.9 1369	26.1 663	24.1 612	394 245	260.0 1677			12 10									
	SRS-7A	E-7		18.00DC		24.2 615	54.8 1392	25.8 655	24.5 622	384 239	232.0 1497			13 10									

See Wide Base Section for 80 aspect ratio tires (e.g. 59/80R63)

Sizes in bold type can be obtained in locations in bold.
Extended lead time may be needed in other locations.

Legend	N = North America	E = Europe / Africa / Mid East	# = Estimated Data	^ = Work Capability Factor
	L = Latin America	A = Asia / Australia	* = Tube Type Tire	

LOAD LIMITS AT COLD INFLATION PRESSURES

5 MPH (10 KM/H) MAXIMUM SPEED OFF-THE-ROAD SAND SERVICE

	PSI	11	15	18	22	25	29	33	36
BIAS	KPA	75	100	125	150	175	200	225	250
24-20.5	LBS	7830	9370	10750	12020	12790	13890	15210	16090
	KG	3530	4250	4875	5450	5800	6300	6900	7300

5 MPH (10 KM/H) MAXIMUM SPEED OFF-THE-ROAD SLOW SPEED SERVICE

	PSI	98	102	105	109	112	116	120	123	127	131	134	138	141
BIAS	KPA	675	700	725	750	775	800	825	850	875	900	925	950	975
7.50-20NHS	LBS	6000	6150	6400	6400▲	6600▲	6800▲	6800▲	6950▲	6950▲	7150▲	7400▲	7400▲	7600(16)▲
	KG	2722	2790	2903	2903▲	2994▲	2994▲	3084▲	3153▲	3153▲	3243▲	3357▲	3357▲	3447(16)▲
BIAS	PSI	73	76	80	83	87	91	94	98	102	105	109	112	116
	KPA	500	525	550	575	600	625	650	675	700	725	750	775	800
9.50-20NHS	LBS	7150	7400	7600	7600	7850(12)	8050	8250	8550	8550(14)	8800	9100▲	9100▲	9350(16)▲
	KG	3250	3350	3450	3450	3530(12)	3650	3750	3875	3875(14)	4000	4125▲	4125▲	4250(16)▲

30 MPH (50 KM/H) MAXIMUM SPEED OFF-THE-ROAD SAND SERVICE

	PSI	11	15	18	22	25	29	33	36
BIAS	KPA	75	100	125	150	175	200	225	250
24-20.5	LBS	6010	7170	8050	9090	9920	10750	11350	12350
	KG	2725	3250	3650	4125	4500	4875	5150	5600

40 MPH (65 KM/H) MAXIMUM SPEED OFF-THE-ROAD SAND SERVICE

	PSI	11	15	18	22	25	29	33	36
BIAS	KPA	75	100	125	150	175	200	225	250
24-20.5	LBS	4940	5840	6780	7390	8270	8820	9370	10200
	KG	2240	2650	3075	3350	3750	4000	4250	4625

55 MPH (90 KM/H) MAXIMUM SPEED OFF-THE-ROAD MINING AND LOGGING SERVICE

	PSI	45	50	55	60	65	70	75	80	85	90	95	100
BIAS	KPA	310	340	380	410	450	480	520	550	590	620	660	690
9.00-20ML	LBS	3120	3310	3525(D)	3690	3870	4080(E)	4200	4360	4540(F)	4670	4670	5070(G)
	KG	1420	1500	1600(D)	1670	1760	1850(E)	1910	1980	2060(F)	2120	2190	2300(G)

Legend ▲ Permafoam inflation or special rim required

CONVENTIONAL SIZE



DIMENSIONAL DATA

Size	Type	Ind Code	Current In Line Location	Rim Width & Flange	Min. Dual Spacing in mm	INFLATED DIMENSIONS				LOADED DIMENSIONS				Revol Per mi km	Gross Contact Area		Tire Volume		Tread Depth		PERFORMANCE CAPABILITY					
						Overall Width in mm		Overall Diameter in mm		Load Sect & Growth in mm		Static Load Rad in mm			in ²	cm ²	gal	ltrs	1/32	in mm	2S tmph tkph		4S tmph tkph		6S tmph tkph	
14.00R21	AT-2A	E-3		10.00-1.5	17.7 450	15.2 386	49.2 1250	16.8 427	22.4 569	427 265	160.0 1032	63.7 241.1	30 24													
16.00-21NHS	HRL-3A	E-3		11.25-2.0	20.2 513	17.0 432	54.3 1379	18.8 478	25.1 638	379 236	185.0 1194	76.0 287.0	37 29													
16.00R21	AT-2A	E-3		10.00-1.5	20.2 513	17.1 434	52.1 1323	18.9 480	23.7 602	403 250	195.0 1258	80.5 304.6	33 26													

See Wide Base Section for 80 aspect ratio tires (e.g. 59/80R63)

Sizes in bold type can be obtained in locations in bold.
Extended lead time may be needed in other locations.

Legend	N = North America	E = Europe / Africa / Mid East	# = Estimated Data	^ = Work Capability Factor
	L = Latin America	A = Asia / Australia	* = Tube Type Tire	

LOAD LIMITS AT COLD INFLATION PRESSURES

5 MPH (10 KM/H) MAXIMUM SPEED OFF-THE-ROAD SAND SERVICE

	PSI	76	80	83	87	91	94	98	102	105	109	112	116	120
RADIAL	KPA	525	550	575	600	625	650	675	700	725	750	775	800	825
16.00R21	LBS	17600	18200*	18700	19300	19800	20400	21500	22000	22700	22700	23400	24000	24700**
(445/90R21)	KG	8000	8250*	8500	8750	9000	9250	9750	10000	10300	10300	10600	10900	11200**

5 MPH (10 KM/H) MAXIMUM SPEED OFF-THE-ROAD SLOW SPEED SERVICE

	PSI	76	80	83	87	91	94	98	102	105	109	112	116	120
RADIAL	KPA	525	550	575	600	625	650	675	700	725	750	775	800	825
14.00R21	LBS	13200	13600*	14300	14800	15200	15700	16100	16500	17100	17100	17600	18200	18700**
	KG	6000	6150*	6500	6700	6900	7100	7300	7500	7750	7750	8000	8250	8500**
16.00R21	LBS	17600	18200*	18700	19300	19800	20400	21500	22000	22700	22700	23400	24000	24700**
	KG	8000	8250*	8500	8750	9000	9250	9750	10000	10300	10300	10600	10900	11200**

30 MPH (50 KM/H) MAXIMUM SPEED OFF-THE-ROAD HAULAGE SERVICE

	PSI	65	69	73	76	80	83	87	91	94	98	102
RADIAL	KPA	450	475	500	525	550	575	600	625	650	675	700
14.00R21	LBS	8250	8550*	8800	9100	9350	9650	10200	10500	10700	11000	11400**
	KG	3750	3875*	4000	4125	4250	4375	4625	4750	4850	5000	5175**
16.00R21	LBS	10500	11000*	11400	11700	12000	12300	12800	13200	13900	14300	14800**
	KG	4750	5000*	5150	5300	5450	5600	6000	6300	6500	6700**	
BIAS	PSI	40	44	47	51	54	58					
	KPA	275	300	325	350	375	400					
16.00-21NHS	LBS	8800	9350	9650(16)	10200	10500	11000(20)					
	KG	4000	4250	4375(16)	4625	4750	5000(20)					

55 MPH (90 KM/H) MAXIMUM SPEED SERVICE

	PSI	55	60	65	70	75	80	85	90	95	100	105	110	115
RADIAL	KPA	375	400	450	475	525	550	575	625	650	700	725	750	800
14.00R21	LBS	6410	6860	7300	7720(G)	8120	8510	8890(H)	9260	9610	9960(J)	10300	10620	10960(L)
	KG	2900	3100	3300	3500(G)	3675	3850	4025(H)	4200	4350	4525(J)	4675	4825	4975(L)
RADIAL	PSI	65	70	75	80	85	90	95	100	105	110			
	KPA	450	480	520	550	590	620	660	690	720	760			
16.00R21	LBS	9990	10560	11110	11650	12160	12660	13150	13900(L)	14350	14800(M)			
(445/90R21)	KG	4530	4790	5040	5280	5520	5740	5960	6300(L)	6500	6700(M)			

Legend

▲ Permafoam inflation or special rim required

CONVENTIONAL SIZE

DIMENSIONAL DATA

BIAS



SRB-7A

Size	Type	Ind Code	Current In Line Location	Rim Width & Flange	Min. Dual Spacing in mm	INFLATED DIMENSIONS				LOADED DIMENSIONS				Gross Contact Area in ² cm ²	Tire Volume gal ltrs	Tread Depth 1/32 in mm	PERFORMANCE CAPABILITY					
						Overall Width in mm		Overall Diameter in mm		Load Sect & Growth in mm		Static Load Rad in mm					Revol Per mi km		2S tmph tkph		4S tmph tkph	
24-21	SRB-7A	E-7	N	18.00-1.5		24.2	615	53.9	1369	26.1	663	24.1	612	394	245	260.0	1677	23	18			
	SRS-7A	E-7		18.00-1.5		24.2	615	54.8	1392	25.8	655	24.5	622	384	239	232.0	1497					

See Wide Base Section for 80 aspect ratio tires (e.g. 59/80R63)

Sizes in bold type can be obtained in locations in bold. Extended lead time may be needed in other locations.

Legend	N = North America	E = Europe / Africa / Mid East	# = Estimated Data	^ = Work Capability Factor
	L = Latin America	A = Asia / Australia	* = Tube Type Tire	

LOAD LIMITS AT COLD INFLATION PRESSURES

5 MPH (10 KM/H) MAXIMUM SPEED OFF-THE-ROAD SAND SERVICE

BIAS	PSI	11	15	18	22	25	29	33	36
	KPA	75	100	125	150	175	200	225	250
24-21	LBS	7830	9370	10750	12020	12790	13890	15210	16090(12)
	KG	3550	4250	4875	5450	5800	6300	6900	7300(12)

40 MPH (65 KM/H) MAXIMUM SPEED OFF-THE-ROAD SAND SERVICE

BIAS	PSI	11	15	18	22	25	29	33	36
	KPA	75	100	125	150	175	200	225	250
24-21	LBS	4940	5840	6780	7390	8270	8820	9370	10200
	KG	2240	2650	3075	3350	3750	4000	4250	4625

Legend

▲ Permafoam inflation or special rim required

CONVENTIONAL SIZE

DIMENSIONAL DATA

BIAS



HRL-3A

SGG-2A

Size	Type	Ind Code	Current In Line Location		Rim Width & Flange	Min. Dual Spacing in mm		INFLATED DIMENSIONS				LOADED DIMENSIONS				Gross Contact Area in ² cm ²		Tire Volume gal ltrs		Tread Depth 1/32 in mm		PERFORMANCE CAPABILITY							
								Overall Width in mm		Overall Diameter in mm		Load Sect & Growth in mm		Static Load Rad in mm								Revol Per mi km		2S tmph tkph		4S tmph tkph		6S tmph tkph	
12.00-24ML	* HRL-3A	E-3	N	E	8.50V	15.4	391	12.8	325	49.5	1257	14.0	356	22.9	582	433	269	140.0	903	47.0	177.0	28	22						
12.00-24TG	SGG-2A	G-2			8.00TG			12.9	328	48.4	1229	14.4	366	22.4	569	425	264	139.0	897			28	22						

See Wide Base Section for 80 aspect ratio tires (e.g. 59/80R63)

Sizes in bold type can be obtained in locations in bold. Extended lead time may be needed in other locations.

Legend	N = North America	E = Europe / Africa / Mid East	# = Estimated Data	^ = Work Capability Factor
	L = Latin America	A = Asia / Australia	* = Tube Type Tire	

LOAD LIMITS AT COLD INFLATION PRESSURES

5 MPH (10 KM/H) MAXIMUM SPEED OFF-THE-ROAD SLOW SPEED SERVICE

BIAS	PSI	36	40	44	47	69	73	76	80	83	87	91	94	98	102	105	Continued
	KPA	250	275	300	325	475	500	525	550	575	600	625	650	675	700	725	
12.00-24TG	LBS	7400	7850	8050	8550(8)	11000	11400	11700	12000	12300	12300	12800	13200	13600(16)	13600	13900	
	KG	3350	3550	3650	3875(8)	5000	5150	5300	5450	5600	5600	5800	6000	6150(16)	6150	6300	
	PSI	109	112	116	120												
	KPA	750	775	800	825												
	LBS	14300▲	14800▲	14800▲	15200(20)▲												
	KG	6500▲	6700▲	6700▲	6900(20)▲												

25 MPH (40 KM/H) MAXIMUM SPEED OFF-THE-ROAD TRACTOR AND GRADER SERVICE

BIAS	PSI	18	22	25	29
	KPA	125	150	175	200
12.00-24TG	LBS	3200	3520(6)	3860	4180(8)
	KG	1450	1600(6)	1750	1900(8)

30 MPH (50 KM/H) MAXIMUM SPEED OFF-THE-ROAD HAULAGE SERVICE

BIAS	PSI	40	44	47	51	54	58	62	65	69	73	76	80
	KPA	275	300	325	350	375	400	425	450	475	500	525	550
12.00-24NHS	LBS	5520	5680	6000	6150	6600(14)	6800	6950	7150(16)	7390	7610	7830	8050(20)
	KG	2500	2575	2725	2800	3000(14)	3075	3150	3250(16)	3350	3450	3550	3650(20)

30 MPH (50 KM/H) MAXIMUM SPEED OFF-THE-ROAD HAULAGE SERVICE

BIAS	PSI	40	44	47	51	54	58	62	65
	KPA	275	300	325	350	375	400	425	450
12.00-24ML	LBS	5520	5680	6000	6150	6600(G)	6800	6950	7150(H)
	KG	2500	2575	2725	2800	3000(G)	3075	3150	3250(H)

50 MPH (80 KM/H) MAXIMUM SPEED OFF-THE-ROAD MINING AND LOGGING SERVICE

BIAS	PSI	55	60	65	70	75	80	85	90	95
	KPA	380	410	450	480	520	550	590	620	660
12.00-24ML	LBS	5550	5840	6120	6390	6650	6940(G)	7160	7410	7830(H)
	KG	2520	2650	2780	2900	3020	3150(G)	3250	3360	3550(H)

Legend

▲ Permafoam inflation or special rim required

CONVENTIONAL SIZE

DIMENSIONAL DATA

RADIAL

BIAS



RL-2F RL-4J SG-2B American Miner RBG-1A RKG-3A SMG-1A SGG-2A

Size	Type	Ind Code	Current In Line Location	Rim Width & Flange	Min. Dual Spacing in mm	INFLATED DIMENSIONS				LOADED DIMENSIONS				Revol Per mi km	Gross Contact Area		Tire Volume		Tread Depth		PERFORMANCE CAPABILITY					
						Overall Width in mm	Overall Diameter in mm	Load Sect & Growth in mm	Static Load Rad in mm	in ² cm ²	gal ltrs	1/32 in mm	2S tmph tkph		4S tmph tkph	6S tmph tkph										
12.00R24NHS *	RL-4J	E-4		8.5	15.4 391	13.3 338	50.3 1275	14.5 368	23.5 599	420 261	113.0 729	46.6 176.4	42 33	75 110	55 80											
13.00-24TG	American Miner #	G-2	N	10.00		13.8 351	50.8 1290	14.6 371	23.3 592				28 22													
	RBG-1A	G-1		8.00TG		13.6 345	50.3 1278	15.8 401	22.8 579	414 257	138.0 890		30 24													
	RKG-3A	G-3		8.00TG		13.3 338	51.3 1303	15.1 384	23.8 605	399 248	123.0 794		30 24													
	SGG-2A	G-2	N L E A	8.00TG		13.5 343	50.0 1285	15.5 395	22.2 563	408 254	118.0 761	54.3 205.0	28 22													
	SMG-1A	G-3S		8.00TG		13.4 340	49.7 1262	15.6 396	22.5 572	423 263	136.0 877															
13.00R24TG	RL-2F	G-2		8.00TG		13.3 337	51.0 1295	14.6 372	23.6 599	412 256	115.0 742	57.9 219.1	27 21													
	SG-2B	G-2	N	8.00TG		13.5 343	50.3 1278		22.8 579	414 257			30 24													

See Wide Base Section for 80 aspect ratio tires (e.g. 59/80R63)

Sizes in bold type can be obtained in locations in bold.
Extended lead time may be needed in other locations.

Legend	N = North America	E = Europe / Africa / Mid East	# = Estimated Data	^ = Work Capability Factor
	L = Latin America	A = Asia / Australia	* = Tube Type Tire	

LOAD LIMITS AT COLD INFLATION PRESSURES

5 MPH (10 KM/H) MAXIMUM SPEED OFF-THE-ROAD SLOW SPEED SERVICE

	PSI	76	80	83	87	91	94	98	102	105	109	112	116	120	131
RADIAL	KPA	525	550	575	600	625	650	675	700	725	750	775	800	825	900
12.00R24NHS	LBS	10700	11400*	11700	12000	12300	12800	13200	13600	13900	14300▲	14300▲	14800▲	15200**▲	16100***▲
	KG	4875	5150*	5300	5450	5600	5800	6000	6150	6300	6500▲	6500▲	6700▲	6900**▲	7300***▲
BIAS	PSI	44	47	51	54	58	62	65	69	73	76	80	83	87	
	KPA	300	325	350	375	400	425	450	475	500	525	550	575	600	
13.00-24TG	LBS	9350(8)	9900	10500	10700(10)	11400	11700	12000(12)	12300	12800	13200(14)	13600	13900	19300(16)	
	KG	4250(8)	4500	4750	5000(10)	5150	5300	5600(12)	5600	5800	6000(14)	6150	6300	6500(16)	
RADIAL	PSI	51	54	58	62	65	69	73	76	80					
	KPA	350	375	400	425	450	475	500	525	550					
13.00R24TG	LBS	9350	9900	10500	11000	11400	12000	12300	12800	13200*					
	KG	4250	4500	4750	5000	5150	5450	5600	5800	6000*					

25 MPH (40 KM/H) MAXIMUM SPEED OFF-THE-ROAD TRACTOR AND GRADER SERVICE

	PSI	18	22	25	29	33	36	40	44
BIAS	KPA	125	150	175	200	225	250	275	300
13.00-24TG	LBS	3740	4180(6)	4540(8)	4940	5200(10)	5520	5840	6000(12)
	KG	1700	1900(6)	2060(8)	2240	2360(10)	2500	2650	2725(12)
RADIAL	PSI	29	33	36	40	44	47	51	54
	KPA	200	225	250	275	300	325	350	375
13.00R24TG	LBS	4080	4400	4800	5200	5520	5840	6150	6600*
	KG	1850	2000	2180	2360	2500	2650	2800	3000*

30 MPH (50 KM/H) MAXIMUM SPEED OFF-THE-ROAD HAULAGE SERVICE

	PSI	65	69	73	76	80	83	87	91	94	98	102	105	109	112	116
RADIAL	KPA	450	475	500	525	550	575	600	625	650	675	700	725	750	775	800
12.00R24NHS	LBS	6400	6600*	6950	7150	7400	7850	8050	8250	8550	8800	8800**	9100	9350▲	9650▲	9900***▲
	KG	2900	3000*	3150	3250	3350	3550	3650	3750	3875	4000	4000**	4125	4250▲	4375▲	4500***▲

Legend ▲ Permafoam inflation or special rim required

CONVENTIONAL SIZE

DIMENSIONAL DATA

BIAS



American Miner SL ELV-3A RBG-1A RKG-3A SGG-4B CHM HRL-3A SGG-2A

Size	Type	Ind Code	Current In Line Location	Rim Width & Flange	Min. Dual Spacing in mm	INFLATED DIMENSIONS				LOADED DIMENSIONS				Revol Per mi km	Gross Contact Area in ² cm ²	Tire Volume gal ltrs	Tread Depth 1/32 in mm	PERFORMANCE CAPABILITY										
						Overall Width in mm		Overall Diameter in mm		Load Sect & Growth in mm		Static Load Rad in mm						2S tmph tkph		4S tmph tkph		6S tmph tkph						
14.00-24NHS	* ELV-3A	IND-3	A	10.00W	18.7 475	15.5	394	54.5	1384	16.0	406	26.0	660	362	225	170.0	1097	33	26									
	* SMO-4B	L-4S		10.00W		17.7	450	14.8	376		55.8		1417					16.0	406				26.0	660	362	225	170.0	1097
14.00-24ML	* CHM	E-3	N L E A	10.00W	17.7 450	14.7	373	52.5	1334	16.0	406	24.6	625	393	244	129.0	832	20	16									
	* HRL-3A					G-2	10.00W	17.7	450		15.5		394					54.5	1384				16.9	429	25.6	650	372	231
14.00-24TG	American Miner SL #	G-2	N L E A	8	8.00TG	14.6	371	53.4	1356	15.6	396	24.4	620	396	246	160.0	1033	32	25.4									
	RBG-1A	G-1		8.00TG		14.4	366	52.6	1336		16.5		419					23.7	602				396	246	160.0	1033	32	25
	RKG-3A	G-3		8.00TG		14.2	361	53.3	1354		16.0		406					24.6	625				387	241	132.0	852	32	25
	SGG-2A	G-2		8.00TG		14.6	370	52.6	1336		16.8		421					23.6	598				391	243	208.0	1345	62.4	236.1
	SGG-4B	G-4	N	8.00TG		14.5	368	54.5	1384	16.9	429	24.6	625	387	241	200.0	1290	50	40									

See Wide Base Section for 80 aspect ratio tires (e.g. 59/80R63)

Sizes in bold type can be obtained in locations in bold. Extended lead time may be needed in other locations.

Legend	N = North America	E = Europe / Africa / Mid East	# = Estimated Data	^ = Work Capability Factor
	L = Latin America	A = Asia / Australia	* = Tube Type Tire	

LOAD LIMITS AT COLD INFLATION PRESSURES

5 MPH (10 KM/H) MAXIMUM SPEED OFF-THE-ROAD SLOW SPEED SERVICE

BIAS	PSI	47	51	54	58	62	65	69	73	76	76	80	80	83	87	91	Continued
	KPA	325	350	375	400	425	450	475	500	525	525	550	550	575	600	625	
14.00-24TG	LBS	12000	12300(10)	13200	13600	13900(12)	14300	14800	15200	15700	15700	16100(16)	16100	16500	17100	17600	
	KG	5450	5600(10)	6000	6150	6300(12)	6500	6700	6900	7100	7100	7300(16)	7300	7500	7750	8000	
	PSI	94	98	102	105	109	112	116	123	141							
	KPA	650	675	700	725	750	775	800	850	975							
	LBS	18200	18200	18700(20)	19300	19300	19800	20400	20900(24)	22700(28)▲							
	KG	8250	8250	8500(20)	8750	8750	9000	9250	9500(24)	10300(28)▲							

25 MPH (40 KM/H) MAXIMUM SPEED OFF-THE-ROAD TRACTOR AND GRADER SERVICE

BIAS	PSI	22	25	29	33	36	40	44	47	51
	KPA	150	175	200	225	250	275	300	325	350
14.00-24TG	LBS	5080	5520	5840	6150(10)	6800(12)	7150	7600	7850	8050(16)
	KG	2300	2500	2650	2800(10)	3075(12)	3250	3450	3550	3650(16)

30 MPH (50 KM/H) MAXIMUM SPEED OFF-THE-ROAD HAULAGE SERVICE

BIAS	PSI	51	54	58	62	65	69	73	76	80	83	87	91	94
	KPA	350	375	400	425	450	475	500	525	550	575	600	625	650
14.00-24NHS	LBS	8550	8800(16)	9350	9650	9900	10200(20)	10500	10700	11000(24)	11400	11700	12000	12300(28)
	KG	3875	4000(16)	4250	4375	4500	4625(20)	4750	4875	5000(24)	5150	5300	5450	5600(28)

30 MPH (50 KM/H) MAXIMUM SPEED OFF-THE-ROAD HAULAGE SERVICE

BIAS	PSI	51	54	58	62	65	69
	KPA	350	375	400	425	450	475
14.00-24ML	LBS	8550	8800(H)	9350	9650	9900	10200(L)
	KG	3875	4000(H)	4250	4375	4500	4625(L)

50 MPH (80 KM/H) MAXIMUM SPEED OFF-THE-ROAD MINING AND LOGGING SERVICE

BIAS	PSI	55	60	65	70	75	80	85	90	95	100
	KPA	380	410	450	480	520	550	590	620	660	690
14.00-24ML	LBS	7560	7960	8340	8820(H)	9070	9410	9920(J)	10090	10410	11000(L)
	KG	3430	3610	3780	4000(H)	4110	4270	4500(J)	4580	4720	5000(L)

Legend ▲ Permafoam inflation or special rim required

CONVENTIONAL SIZE

DIMENSIONAL DATA

RADIAL



AS-3A EV-4S EV-4A (24/24) GP-2B RL-2F RL-4J EV-4M RL-5K (24/24) RL-5K (08/08) RL-5K (12/12) RL-4S SG-2B MC-1A

Size	Type	Ind Code	Current In Line Location	Rim Width & Flange	Min. Dual Spacing in mm	INFLATED DIMENSIONS				LOADED DIMENSIONS				Revol Per mi km	Gross Contact Area		Tire Volume		Tread Depth		PERFORMANCE CAPABILITY				
						Overall Width in mm	Overall Diameter in mm	Load Sect & Growth in mm	Static Load Rad in mm	in ²	cm ²	gal	ltrs		1/32 in	mm	2S tmph tkph	4S tmph tkph	6S tmph tkph						
14.00R24	MC-1A	E-1		10.00W	17.7 450	14.7	373	53.5	1359	16.0	406	24.7	627	393	244	123.0	794	75.0	284.0	31	24				
	RL-4S #	L-4S	L	10.00W		15.6	396	55.4	1407	17.1	434	24.6	624	379.2	235.6	153.8	992	75.0	284.0	50	39				
14.00R24NHS	EV-4A (24/24)	IND-4	N E	10.00W	18.7 475	15.6	396	55.4	1407	17.9	455	25.5	648	454	282	235.0	1516	68.7	260.0	49	39		^65	^100	
	EV-4M	IND-4		10.00W	18.7 475	14.7	373	55.5	1410	16.8	427	24.6	625	378	236	167.0	1079	67.6	256.0	47	37				
	* EV-4S	IND-4S	N E	10.00W	18.7 475	15.6	396	55.4	1407	17.9	455	25.0	634	454	282	235.0	1516	68.7	260.0	62	49		^58	^90	
	GP-2B	E-3			17.7 450	15.2	386	53.5	1359	15.5	394	24.4	620	393	244	152.0	981			33	26				
	RL-2F	E-2	A	10.00W	17.7 450	15.0	381	53.8	1367	16.5	419	24.8	630	390	242	138.0	890	75.1	284.2	29	23	110	160	85	120
	* RL-4J	E-4	N	10.00W	17.7 450	15.3	389	55.6	1412	16.7	424	25.9	658	377	234	154.0	994	68.2	258.1	48	38	85	120	65	95
	RL-5K (08/08)	E-5		10.00W	17.7 450	15.0	381	55.8	1417	16.2	411	26.0	660	362	225	190.0	1226			81	64				
	RL-5K (08/08)	L-5		10.00W	17.7 450	15.0	381	55.8	1417	16.2	411	26.0	660	362	225	190.0	1226			81	64				
	RL-5K (12/12)	E-5		10.00W	17.7 450	15.0	381	55.8	1417	16.2	411	26.0	660	362	225	190.0	1226			81	64				
	RL-5K (24/24)	L-5		10.00W	17.7 450	15.0	381	55.8	1417	16.2	411	26.0	660	362	225	190.0	1226			81	64				
14.00R24TG	AS-3A	G-3	N	8.00TG		14.4	367	53.2	1352	16.6	422	24.1	612	395	245	205.0	1323	75.4	285.4	32	25				
	RL-2F	G-2		8.00TG		14.2	361	53.8	1367	15.7	399	24.7	628	390	242	138.0	890	75.1	284.2	29	23				
	SG-2A	G-2		8.00TG		14.4	367	53.2	1352	16.6	422	24.1	612	395	245	186.0	1200	75.4	285.4	25	19				
	SG-2B	G-2	N	8.00TG		14.4	367	53.2	1352	16.6	422	24.1	612	395	245	186.0	1200	75.4	285.4	33	26				

See Wide Base Section for 80 aspect ratio tires (e.g. 59/80R63)

Sizes in bold type can be obtained in locations in bold. Extended lead time may be needed in other locations.

Legend	N = North America L = Latin America	E = Europe / Africa / Mid East A = Asia / Australia	# = Estimated Data * = Tube Type Tire	^ = Work Capability Factor
---------------	--	--	--	----------------------------

LOAD LIMITS AT COLD INFLATION PRESSURES

5 MPH (10 KM/H) MAXIMUM SPEED OFF-THE-ROAD SLOW SPEED SERVICE

RADIAL	PSI	76	80	83	87	91	94	98	102	105	109	112	116	120	131
	KPA	525	550	575	600	625	650	675	700	725	750	775	800	825	900
14.00R24NHS	LBS	14800	15200*	15700	16500	17100	17600	17600	18200	18700	19300	19800	20400	20900**	22000***▲
	KG	6700	6900*	7100	7500	7750	8000	8000	8250	8500	8750	9000	9250	9500**	10000***▲

25 MPH (40 KM/H) MAXIMUM SPEED OFF-THE-ROAD TRACTOR AND GRADER SERVICE

RADIAL	PSI	29	33	36	40	44	47	51	54	58	62	65	69	73	76	80
	KPA	200	225	250	275	300	325	350	375	400	425	450	475	500	525	550
14.00R24TG	LBS	4940	5360	5840	6150	6600	7150	7400	8050*	8250	8550	9100	9350	9900	10200	10500**
	KG	2240	2430	2650	2800	3000	3250	3350	3650*	3750	3875	4125	4250	4500	4625	4750**

30 MPH (50 KM/H) MAXIMUM SPEED OFF-THE-ROAD HAULAGE SERVICE

RADIAL	PSI	65	69	73	76	80	83	87	91	94	98	102	105	109	112	116
	KPA	450	475	500	525	550	575	600	625	650	675	700	725	750	775	800
14.00R24NHS	LBS	8800	9100*	9650	9900	10200	10500	11000	11400	11700	12000	12300**	12300	12800	13200	13600***
	KG	4000	4125*	4375	4500	4625	4750	5000	5150	5300	5450	5600**	5600	5800	6000	6150***

55 MPH (90 KM/H) MAXIMUM SPEED SERVICE

RADIAL	PSI	65	70	75	80	85	90	95	100	105	110	115	131	141
	KPA	450	475	525	550	575	625	650	700	725	750	800	900	975
14.00R24	LBS	8150	8620	9070	9500	9930	10340	10730	11400(J)	11700	12000	12300(L)	13270(M)	13930(N)
	KG	3700	3910	4110	4310	4500	4690	4870	5150(J)	5300	5450	5600(L)	6000(M)	6300(N)

Legend

▲ Permafoam inflation or special rim required

CONVENTIONAL SIZE

DIMENSIONAL DATA



Size	Type	Ind Code	Current In Line Location	Rim Width & Flange	Min. Dual Spacing in mm	INFLATED DIMENSIONS				LOADED DIMENSIONS				Revol Per mi km	Gross Contact Area		Tire Volume		Tread Depth		PERFORMANCE CAPABILITY			
						Overall Width in mm	Overall Diameter in mm	Load Sect & Growth in mm	Static Load Rad in mm	in ²	cm ²	gal	ltrs		1/32	mm	2S tmph tkph	4S tmph tkph	6S tmph tkph					
16.00-24	H R Lug XT	E-4		11.25-2.0	20.2 513	17.2	437	59.9	1521	18.8	478	28.0	711	339	211	190.0	1226	78.0	295.0	67	53			
	HRL-3A	E-3	N A	11.25-2.0		17.4	442	58.1	1476	19.2	488	26.9	683	350	218	195.0	1258	83.0	315.0	37	29			
16.00-24TG	PVG-7A	E-7	N	10.00VA	20.2 513	20.4	520	59.0	1498	22.8	579	24.7	628	355	220	314.0	2026			15	12			
	PVG-7A	G-7	N	10.00VA		20.4	520	59.0	1498	22.8	579	24.7	628	355	220	314.0	2026			15	12			
	RBG-1A	G-1		10.00VA		17.3	439	57.0	1448	19.6	498	25.6	650	371	231	210.0	1355			35	28			
	RKG-3A	G-3		10.00VA		17.3	439	57.8	1468	19.4	493	26.3	668	361	224	212.0	1368			35	28			
	SGG-2A	G-2	N L E A	10.00VA		16.9	429	56.1	1425	19.2	488	25.4	645	374	232	226.0	1458	79.0	298.0	35	28			
16.00R24TG	RL-2F	G-2		10.00VA	20.2 513	16.7	424	58.8	1494	18.4	468	26.9	683	357	222	180.0	1160	108.6	411.1	32	25			
	SG-2B	G-2		10.00VA		16.8	426	57.3	1454	18.5	469	25.4	644	367	228	185.0	1190	100.0	379.0	35	28			
18.00-24	HRL-3A	E-3		13.00-2.5	23.1 587	20.0	508	64.0	1626	22.2	564	29.5	749	319	198	260.0	1678			39	31			
20-24	SGL D/L-2A	L-2	L	16.00-1.4		21.5	545	54.3	1380	23.6	600	24.1	612	395	245	314.0	2026			33	26			

See Wide Base Section for 80 aspect ratio tires (e.g. 59/80R63)

Sizes in bold type can be obtained in locations in bold.
Extended lead time may be needed in other locations.

Legend	N = North America	E = Europe / Africa / Mid East	# = Estimated Data	^ = Work Capability Factor
	L = Latin America	A = Asia / Australia	* = Tube Type Tire	

LOAD LIMITS AT COLD INFLATION PRESSURES

5 MPH (10 KM/H) MAXIMUM SPEED OFF-THE-ROAD SLOW SPEED SERVICE

	PSI	44	47	51	54	58	62	65	69
BIAS	KPA	300	325	350	375	400	425	450	475
16.00-24TG	LBS	14780	15700(12)	16100	17100	17600	18200(16)	18700	19300
	KG	6700	7100(12)	7300	7750	8000	8250(16)	8500	8750

25 MPH (40 KM/H) MAXIMUM SPEED OFF-THE-ROAD TRACTOR AND GRADER SERVICE

	PSI	22	25	29	33	36	40	44		
BIAS	KPA	150	175	200	225	250	275	300		
16.00-24TG	LBS	6600	7150	7600	8050(12)	8800	9350	9900(16)		
	KG	3000	3250	3450	3650(12)	4000	4250	4500(16)		
	PSI	25	29	33	36	40	44	47	51	54
RADIAL	KPA	175	200	225	250	275	300	325	350	375
16.00R24TG	LBS	5680	6400	6950	7400	8050	8550	9100	9650	10200*
	KG	2525	2900	3150	3250	3650	4000	4125	4375	4625*

30 MPH (50 KM/H) MAXIMUM SPEED OFF-THE-ROAD HAULAGE SERVICE

	PSI	40	44	47	51	54	58		
BIAS	KPA	275	300	325	350	375	400		
16.00-24	LBS	9650	10200(16)	10700	11000	11700	12000(20)		
	KG	4375	4625(16)	4875	5000	5300	5450(20)		
BIAS	PSI	40	44	47	51	54	58	62	
	KPA	275	300	325	350	375	400	425	
18.00-24	LBS	12300(16)	13200	13900	14300(20)	15200	15700	16100(24)	
	KG	5600(16)	6000	6300	6500(20)	6900	7100	7300(24)	
BIAS	PSI	29	33						
	KPA	200	225						
20-24	LBS	9370(12)	10750(14)						
	KG	4250(12)	4875(14)						

Legend

▲ Permafoam inflation or special rim required

CONVENTIONAL SIZE

DIMENSIONAL DATA

RADIAL

BIAS

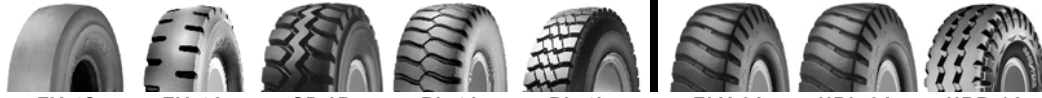

EV-4S EV-4A GP-2B RL-4J RL-4L ELV-3A HRL-3A HRR-1A

Size	Type	Ind Code	Current In Line Location		Rim Width & Flange	Min. Dual Spacing in mm	INFLATED DIMENSIONS		LOADED DIMENSIONS		Revol Per mi km	Gross Contact Area		Tire Volume		Tread Depth		PERFORMANCE CAPABILITY		
							Overall Width in mm	Overall Diameter in mm	Load Sect & Growth in mm	Static Load Rad in mm		in ²	cm ²	gal	ltrs	1/32	in mm	2S tmph tkph	4S tmph tkph	6S tmph tkph
14.00-25NHS	ELV-3A	IND-3			10.00	18.7 475														
14.00-25ML	HRL-3A	E-3	N	E A	10.00	17.7 450	15.0 381	54.5 1384	16.5 419	25.5 648	373 231	149.0 961	56.0 211.0	33 26			50 70			
	HRR-1A	E-1			10.00	17.7 450	14.8 375	53.8 1368	15.9 405	26.0 660	362 225	170.0 1097								
14.00R25	EV-4S #	IND-4S		L	10.00x1.5		15.6 396	55.4 1407	17.1 434	24.6 624	379.2235.6	153.8 992	75.0 284.0	50 39						
14.00R25NHS *	EV-4A	IND-4		E	10.00	18.7 475	15.6 396	55.4 1407	17.7 450	22.7 577	444 276	190.0 1226		49 39						
	GP-2B	E-3			10.00	17.7 450	15.2 386	53.5 1359	15.5 394	24.4 620	393 244	152.0 981		33 26						
	RL-4J	E-4	N	A	10.00	17.7 450	15.3 389	55.6 1412	16.7 424	25.9 658	377 234	154.0 994	68.2 258.1	48 38	85 120	65 95				
	RL-4L	E-4			N	10.00	17.7 450	14.7 373	55.5 1410	16.8 427	24.6 625	378 236	167.0 1079	66.4 251.3	47 37					

See Wide Base Section for 80 aspect ratio tires (e.g. 59/80R63)

Sizes in bold type can be obtained in locations in bold.
Extended lead time may be needed in other locations.

Legend	N = North America	E = Europe / Africa / Mid East	# = Estimated Data	^ = Work Capability Factor
	L = Latin America	A = Asia / Australia	* = Tube Type Tire	

LOAD LIMITS AT COLD INFLATION PRESSURES

5 MPH (10 KM/H) MAXIMUM SPEED OFF-THE-ROAD SLOW SPEED SERVICE

	PSI	76	80	83	87	91	94	98	102	105	109	112	116	123	141
BIAS	KPA	525	550	575	600	625	650	675	700	725	750	775	800	850	975
14.00-25NHS	LBS	15700	16100	16500	17100	17600	18200	18200	18700(20)	19300	19300	19800	20400	20900(24)	22700(28)▲
	KG	7100	7300	7500	7750	8000	8250	8250	8500(20)	8750	8750	9000	9250	9500(24)	10300(28)▲
RADIAL	PSI	76	80	83	87	91	94	98	102	105	109	112	116	120	131
	KPA	525	550	575	600	625	650	675	700	725	750	775	800	825	900
14.00R25NHS	LBS	14800	15200*	15700	16500	17100	17600	17600	18200	18700	19300	19800	20400	20900**	22000***▲
	KG	6700	6900*	7100	7500	7750	8000	8000	8250	8500	8750	9000	9250	9500**	10000***▲

30 MPH (50 KM/H) MAXIMUM SPEED OFF-THE-ROAD HAULAGE SERVICE

	PSI	51	54	58	62	65	69	73	76	80	83	87	91	94		
BIAS	KPA	350	375	400	425	450	475	500	525	550	575	600	625	650		
14.00-25NHS	LBS	8550	8800(16)	9350	9650	9900	10200(20)	10500	10700	11000(24)	11400	11700	12000	12300(28)		
	KG	3875	4000(16)	4250	4375	4500	4625(20)	4750	4875	5000(24)	5150	5300	5450	5600(28)		
RADIAL	PSI	65	69	73	76	80	83	87	91	94	98	102	105	109	112	116
	KPA	450	475	500	525	550	575	600	625	650	675	700	725	750	775	800
14.00R25NHS	LBS	8800	9100*	9650	9900	10200	10500	11000	11400	11700	12000	12300**	12300	12800	13200	13600***
	KG	4000	4125*	4375	4500	4625	4750	5000	5150	5300	5450	5600**	5600	5800	6000	6150***

30 MPH (50 KM/H) MAXIMUM SPEED OFF-THE-ROAD HAULAGE SERVICE

	PSI	51	54	58	62	65	69
BIAS	KPA	350	375	400	425	450	475
14.00-25ML	LBS	8550	8800(H)	9350	9650	9900	10200(L)
	KG	3875	4000(H)	4250	4375	4500	4625(L)

50 MPH (80 KM/H) MAXIMUM SPEED OFF-THE-ROAD MINING AND LOGGING SERVICE

	PSI	55	60	65	70	75	80	85	90	95	100
BIAS	KPA	380	410	450	480	520	550	590	620	660	690
14.00-25ML	LBS	7560	7960	8340	8820(H)	9070	9410	9920(J)	10090	10410	11000(L)
	KG	3430	3610	3780	4000(H)	4110	4270	4500(J)	4580	4720	5000(L)

Legend

▲ Permafoam inflation or special rim required

CONVENTIONAL SIZE

DIMENSIONAL DATA

BIAS



ELV-4/5A ELV-3A ELV-3C SMO-5A HRL-3A HRR-1A HRL-4B

Size	Type	Ind Code	Current In Line Location	Rim Width & Flange	Min. Dual Spacing in mm	INFLATED DIMENSIONS				LOADED DIMENSIONS				Revol Per mi km	Gross Contact Area in ² cm ²	Tire Volume gal ltrs	Tread Depth 1/32 in mm	PERFORMANCE CAPABILITY					
						Overall Width in mm		Overall Diameter in mm		Load Sect & Growth in mm		Static Load Rad in mm						2S tmph tkph		4S tmph tkph		6S tmph tkph	
16.00-25	ELV-3A	IND-3	L A	11.25-2.0	20.2 513	17.4 442	58.1 1476	19.2 488	26.9 683	353 219	195.0 1258	80.0 302.0	37 29										
	ELV-3C	IND-3	A	11.25-2.0	20.4 518	16.6 422	59.4 1509	18.4 467	27.3 692	349 217			61 52										
	ELV-4/5A	IND-4		11.25-2.0	20.2 513	17.4 442	59.9 1521	19.4 493	27.6 701	353 219	200.0 1290		66 52										
	HRL-3A	E-3	N L E A	11.25-2.0	20.2 513	17.4 442	58.1 1476	19.2 488	26.9 683	353 219	195.0 1258	80.0 302.0	37 29			70 100							
	HRL-4B	E-4	N L	11.25-2.0	20.2 513	17.2 437	59.9 1521	18.8 478	28.0 711	339 211	190.0 1226	78.0 295.0	67 53	90 130	65 95								
	HRR-1A	E-1		11.25-2.0	20.2 513	16.8 427	57.1 1450	18.4 467	26.5 673	358 222	186.0 1200		37 29	125 180	90 130								
	SMO-5A	L-5S	E	11.25-2.0	20.2 513	17.4 442	59.9 1521	19.2 488	27.6 701	343 213	203.0 1310		89 70										

See Wide Base Section for 80 aspect ratio tires (e.g. 59/80R63)

Sizes in bold type can be obtained in locations in bold.
Extended lead time may be needed in other locations.

Legend	N = North America	E = Europe / Africa / Mid East	# = Estimated Data	^ = Work Capability Factor
	L = Latin America	A = Asia / Australia	* = Tube Type Tire	

LOAD LIMITS AT COLD INFLATION PRESSURES

5 MPH (10 KM/H) MAXIMUM SPEED OFF-THE-ROAD SLOW SPEED SERVICE

BIAS	PSI	69	73	76	80	83	87	91	94	98	102	105	109	112	116	120	
	KPA	475	500	525	550	575	600	625	650	675	700	725	750	775	800	825	Continued
16.00-25	LBS	19300	19800	20400	21500(20)	22000	22000	22700	23400(24)	24000	24700	24700	25400(28)	26000	26800	26800	
	KG	8750	9000	9250	9750(20)	10000	10000	10300	10600(24)	10900	11200	11200	11500(28)	11800	12150	12150	
	PSI	123	127	131	134	138	141	145	149	▲							
	KPA	850	875	900	925	950	975	1000	1025								
	LBS	27600	27600(32)	28300	29100	29100	30000(36)	30000	30900	32000(40)▲							
	KG	12500	12500(32)	12850	13200	13200	13600(36)	13600	14000	14500(40)▲							

30 MPH (50 KM/H) MAXIMUM SPEED OFF-THE-ROAD HAULAGE SERVICE

BIAS	PSI	40	44	47	51	54	58	62	65	69	73	76	80	83	94	
	KPA	275	300	325	350	375	400	425	450	475	500	525	550	575	650	
16.00-25	LBS	9650	10200	10700	11000	11700	12000(20)	12300	12800	13200(24)	13900	14300	14300	14800(28)	16100(32)	
	KG	4375	4625	4875	5000	5300	5450(20)	5600	5800	6000(24)	6300	6500	6500	6700(28)	7300(32)	

Legend

▲ Permafoam inflation or special rim required

CONVENTIONAL SIZE

DIMENSIONAL DATA

RADIAL



EV-3+ EV-4C EV-4S EV-4R EV-4A 00/12 EV-4A (24/24) GP-2B RL-2F RL-3+ EV-5K EV-4K 00/12 EV-4K 12/12 EV-5S

Size	Type	Ind Code	Current In Line Location		Rim Width & Flange	Min. Dual Spacing in mm	INFLATED DIMENSIONS				LOADED DIMENSIONS				Gross Contact Area in ² cm ²		Tire Volume gal ltrs		Tread Depth 1/32 in mm		PERFORMANCE CAPABILITY					
							Overall Width in mm	Overall Diameter in mm	Load Sect & Growth in mm	Static Load Rad in mm	Revol Per mi km	2S tmph tkph	4S tmph tkph	6S tmph tkph												
16.00R25	EV-3+	IND-3+	E		11.25-2.0	20.2 513	17.2 437	59.1 1501	19.2 488	27.1 687	355 221	202.0 1303	94.7 358.3	50 40												
	EV-4A (24/24)	IND-4	N	E	11.25-2.0	20.2 513	17.7 450	60.4 1534	20.5 521	26.9 683	348 216	282.0 1819	100.0 379.0	58 46				80 120								
	EV-4A 00/12	IND-4	N	E	11.25-2.0	20.2 513	17.7 450	60.4 1534	20.5 521	26.9 683	348 216	282.0 1819	100.0 379.0	58 46				70 100								
	EV-4B+	IND-4			11.25-2.0	20.2 513	17.1 435	60.2 1530	19.1 486	26.5 673	349 217	200.0 1290		69 55												
	EV-4C #	IND-4		L	11.25x2.0		17.1 435	60.2 1530	18.8 479	26.7 678	348.8 216.7	317.2 1903	99.0 374.0	63 50												
	EV-4K 00/12	IND-4			11.25-2.0	20.2 513	17.7 450	60.2 1529	19.5 496	26.7 678	349 217	200.0 1290		65 51												
	EV-4K 12/12	IND-4			11.25-2.0	20.2 513	17.7 450	60.2 1529	19.5 496	26.7 678	349 217	200.0 1290		65 51												
	EV-4R	IND-4	N	E	11.25-2.0		17.1 435	60.2 1530	20.3 515	26.5 673	349 217	283.0 1827	97.0 366.0	63 50												
	EV-4S	IND-4S	N	A	11.25-2.0	20.2 513	17.7 450	60.2 1529	19.5 496	26.7 678	349 217	200.0 1290	93.9 355.7	71 56												
	EV-5K	IND-5			11.25-2.0	20.2 513	17.7 450	60.2 1529	19.5 496	26.7 678	349 217	200.0 1290		90 72												
	EV-5S	IND-5S			11.25-2.0	20.2 513	17.7 450	60.2 1529	19.5 496	26.7 678	349 217	200.0 1290	86.7 328.2	90 72												
	GP-2B	E-3		E	11.25-2.0	20.2 513	17.2 438	58.6 1489	19.0 482	27.3 693	358 223		96.2 364.3	34 27												
	GP-2B	L-3		E	11.25-2.0	20.2 513	17.2 438	58.6 1489	19.0 482	27.3 693	358 223		96.2 364.3	34 27												
	RL-2F	E-2			11.25-2.0	20.2 513	17.6 447	59.0 1499	19.3 490	26.9 683	356 221	200.0 1290	98.1 371.5	32 25				130 190	100 150							
	RL-3+	E-3+	N	E A	11.25-2.0	20.2 513	17.2 437	59.1 1501	19.2 488	27.1 687	355 221	202.0 1303	94.7 358.3	50 40	115 170	85 120	70 100									

See Wide Base Section for 80 aspect ratio tires (e.g. 59/80R63)

Sizes in bold type can be obtained in locations in bold. Extended lead time may be needed in other locations.

Legend	N = North America L = Latin America	E = Europe / Africa / Mid East A = Asia / Australia	# = Estimated Data * = Tube Type Tire	^ = Work Capability Factor
---------------	--	--	--	----------------------------

LOAD LIMITS AT COLD INFLATION PRESSURES

5 MPH (10 KM/H) MAXIMUM SPEED OFF-THE-ROAD SLOW SPEED SERVICE

	PSI	76	80	83	87	91	94	98	102	105	109	112	116	120	131
RADIAL	KPA	525	550	575	600	625	650	675	700	725	750	775	800	825	900
16.00R25	LBS	19300	19800*	20400	21500	22000	22700	23400	24000	24700	25400	26000	26800	26800**	29100***
	KG	8750	9000*	9250	9750	10000	10300	10600	10900	11200	11500	11800	12150	12150**	13200***

30 MPH (50 KM/H) MAXIMUM SPEED OFF-THE-ROAD HAULAGE SERVICE

	PSI	65	69	73	76	80	83	87	91	94	98	102
RADIAL	KPA	450	475	500	525	550	575	600	625	650	675	700
16.00R25	LBS	11400	12000*	12300	12800	13200	13900	14300	14800	15200	15700	16100**
	KG	5150	5450*	5600	5800	6000	6300	6500	6700	6900	7100	7300**

Legend

▲ Permafoam inflation or special rim required

CONVENTIONAL SIZE

DIMENSIONAL DATA

BIAS

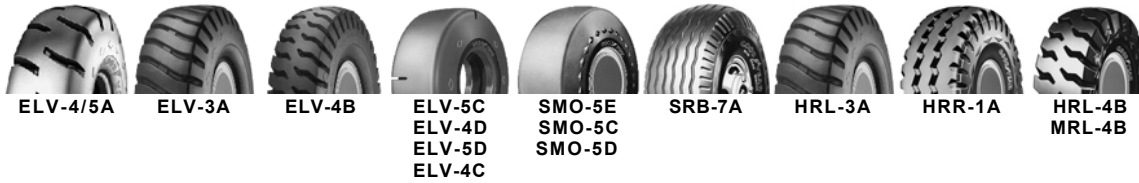

Size	Type	Ind Code	Current In Line Location	Rim Width & Flange	Min. Dual Spacing in mm	INFLATED DIMENSIONS		LOADED DIMENSIONS		Revol Per mi km	Gross Contact Area in ² cm ²		Tire Volume gal ltrs		Tread Depth 1/32 in mm		PERFORMANCE CAPABILITY		
						Overall Width in mm	Overall Diameter in mm	Load Sect & Growth in mm	Static Load Rad in mm		in ²	cm ²	gal	ltrs	in	mm	2S tmph tkph	4S tmph tkph	6S tmph tkph
18.00-25	EAW-7A	E-7		13.00-2.5	23.1 587	20.2 513	63.2 1605	22.5 572	28.5 724	330 205	282.0 1820		22 17						
	ELV-3A	IND-3		13.00-2.5	23.1 587	20.4 518	63.2 1605	22.5 572	29.3 744	321 199	274.0 1768	124.2 470.0	39 31						
	ELV-4/5A	IND-4	N	13.00-2.5	23.1 587	20.8 529	66.5 1689	24.0 609	28.9 733	312 191	334.0 2186		66 52						
	ELV-4B	IND-4	N L A	13.00-2.5	23.1 587	20.8 529	65.8 1671	22.8 580	30.0 761	309 192	269.0 1732	122.2 462.6	69 55						
	ELV-4C	IND-4		13.00-2.5	23.1 587	20.4 518	65.4 1661	22.8 580	30.1 764	311 193	265.0 1710		82 65						
	ELV-4D	IND-4		13.00-2.5	23.1 587	20.4 518	66.0 1677	23.7 602	30.8 782	312 194	340.0 2192		73 53						
	ELV-5C	IND-5		13.00-2.5	23.1 587	20.4 518	65.4 1661	22.8 580	30.1 765	311 190	265.0 1710		114 90						
	ELV-5D	IND-5S	N	13.00-2.5	23.1 587	20.4 518	66.0 1677	23.7 602	30.8 782	312 194	340.0 2192		105 83						
	ELV-5E	IND-5		13.00-2.5	23.1 587	20.7 526	64.7 1643	21.9 556	29.9 760	321 199	255.0 1645		99 79						
	HRL-3A	E-3	L E A	13.00-2.5	23.1 587	20.4 518	63.6 1615	22.5 572	29.3 744	321 199	274.0 1768	131.8 498.9	39 31	125 180	90 130				
	HRL-4B	E-4	N L E A	13.00-2.5	23.1 587	20.3 516	65.2 1656	22.1 561	30.4 772	310 193	235.0 1516	122.2 462.6	70 56		80 120				
	HRR-1A	E-1		13.00-2.5	23.1 587	20.5 521	63.8 1621	22.9 582	29.2 742	323 201	233.0 1503		39 31	145 210	100 150				
	MRL-4B	E-4	L	13.00-2.5	23.1 587	20.3 516	65.2 1656	22.1 561	30.4 772	310 193	235.0 1516		74 59						
	SG	E-2	N	13.00-2.5	23.1 587	20.3 516	63.2 1605	22.4 569	28.8 732	327 203	279.0 1800	113.0 426.0	39 31		100 150				
	SG	G-2	N	13.00-2.5	23.1 587	20.3 516	63.2 1605	22.4 569	28.8 732	327 203	279.0 1800	113.0 426.0	39 31		100 150				
	SMO-5C	L-5S	N L A	13.00-2.5	23.1 587	20.4 518	65.4 1661	22.8 580	30.1 765	311 190	265.0 1710	119.0 450.3	114 90						
	SMO-5D	L-5S	N L A	13.00-2.5	23.1 587	20.6 523	65.6 1666	22.2 564	30.2 767	312 191	265.0 1710	119.0 450.3	102 81						
	SMO-5E	L-5S	N	13.00-2.5	23.1 587	21.5 546	64.7 1643	22.1 561	28.9 734	321 199	255.0 1645		99 79						
SRB-7A	E-7	N	10.00-1.5	21.7 551	18.8 478	60.5 1537	21.2 539	27.2 691	345 214	240.0 1548	123.1 466.0	16 13			160 230				

See Wide Base Section for 80 aspect ratio tires (e.g. 59/80R63)

Sizes in bold type can be obtained in locations in bold. Extended lead time may be needed in other locations.

Legend	N = North America L = Latin America	E = Europe / Africa / Mid East A = Asia / Australia	# = Estimated Data * = Tube Type Tire	^ = Work Capability Factor
---------------	--	--	--	----------------------------

LOAD LIMITS AT COLD INFLATION PRESSURES

5 MPH (10 KM/H) MAXIMUM SPEED OFF-THE-ROAD SLOW SPEED SERVICE

BIAS	PSI	69	73	76	80	83	87	91	94	98	102	105	109	112	116	120	
	KPA	475	500	525	550	575	600	625	650	675	700	725	750	775	800	825	Continued
18.00-25	LBS	25400(20)	26000	26800	27600(24)	28300	29100	30000	30000(28)	30900	32000	32000	33100(32)	33100	34200	35300	
	KG	11500(20)	11800	12150	12500(24)	12850	13200	13600	13600(28)	14000	14500	14500	15000(32)	15000	15500	16000	
	PSI	123	127	131	134	138											
	KPA	850	875	900	925	950											
	LBS	35300(36)	36400	36400	37500	37500(40)											
	KG	16000(36)	16500	16500	17000	17000(40)											

25 MPH (40 KM/H) MAXIMUM SPEED OFF-THE-ROAD TRACTOR AND GRADER SERVICE

BIAS	PSI	25	29	33	36
	KPA	175	200	225	250
18.00-25	LBS	8550	9100(12)	9900	11000(16)
	KG	3875	4125(12)	4500	5000(16)

30 MPH (50 KM/H) MAXIMUM SPEED OFF-THE-ROAD HAULAGE SERVICE

BIAS	PSI	40	44	47	51	54	58	62	65	69	73	76	80	83	102
	KPA	275	300	325	350	375	400	425	450	475	500	525	550	575	700
18.00-25	LBS	12300(16)	13200	13900	14300(20)	15200	15700	16100(24)	16500	17100	17600(28)	18200	18700	19300(32)	21500(40)
	KG	5600(16)	6000	6300	6500(20)	6900	7100	7300(24)	7500	7750	8000(28)	8250	8500	8750(32)	9750(40)

40 MPH (65 KM/H) MAXIMUM SPEED OFF-THE-ROAD SAND SERVICE

BIAS	PSI	11	15	18	22	25	29	33	36
	KPA	75	100	125	150	175	200	225	250
18.00-25	LBS	4940	5840	6610	7390	8050	8820	9370	9920
	KG	2240	2650	3000	3350	3650	4000	4250	4500

Legend

▲ Permafoam inflation or special rim required

CONVENTIONAL SIZE

DIMENSIONAL DATA

RADIAL



EV-3+ EV-4C EV-4K EV-4S EV-4R EV-5S EV-5K EV-5K RL-2F RL-3+ RL-4 RL-4B RL-4J RL-5S SM-5A

Size	Type	Ind Code	Current In Line Location		Rim Width & Flange	Min. Dual Spacing in mm		INFLATED DIMENSIONS		LOADED DIMENSIONS		Revol Per mi km	Gross Contact Area in ² cm ²		Tire Volume gal ltrs		Tread Depth 1/32 in mm		PERFORMANCE CAPABILITY											
								Overall Width in mm	Overall Diameter in mm	Load Sect & Growth in mm	Static Load Rad in mm		in ²	cm ²	gal	ltrs	in	mm	2S tmph tkph		4S tmph tkph		6S tmph tkph							
18.00R25	EV-3+	IND-3+	N	E A	13.00-2.5	23.1	587	20.1	511	64.5	1638	21.7	551	29.2	742	329	204	248.0	1600	135.7	513.7	53	42							
	EV-4C #	IND-4		L	13.00-2.5			19.5	495	65.7	1669	21.6	549	28.9	735	317.6	197.3	276.8	1786	125.0	473.0	81	64							
	EV-4K	IND-4	N	E	13.00-2.5	23.1	587	20.2	513	65.8	1671	21.9	557	30.6	776	319	198	349.0	2252	132.3	500.9	68	54							
	EV-4R #	IND-4		L	13.00-2.5			19.5	495	65.7	1669	21.6	549	28.9	735	317.6	197.3	276.8	1786	125.0	473.0	73	57.9							
	EV-4S	IND-4S	N	E A	13.00-2.5	23.1	587	20.4	517	65.9	1674	21.9	557	28.9	735	319	198	350.0	2261	132.3	500.9	79	63							
	EV-5K	IND-5		E	13.00-2.5	23.1	587	20.2	513	65.8	1671	21.9	557	29.8	757	319	198	302.0	1948	132.1	500.0	99	78							
	EV-5S	IND-5S	N	E	13.00-2.5	23.1	587	20.2	513	65.8	1671	21.9	557	30.6	776	319	198	327.0	2110	119.4	452.0	114	90							
	RL-2F	E-2			13.00-2.5	23.1	587	19.6	498	63.6	1615	21.5	546	28.9	734	330	205	263.0	1696	136.7	517.3	37	29	170	250	130	190			
	RL-3+	E-3+	N	E A	13.00-2.5	23.1	587	20.1	511	64.5	1638	21.7	551	29.2	742	329	204	248.0	1600	135.7	513.7	53	42	155	230	115	170	95	140	
	RL-4	E-4	N	E	13.00-2.5	23.1	587	19.9	505	65.2	1656	21.8	554	29.8	757	322	200	271.0	1748	138.7	525.1	68	54	125	180	95	140	75	110	
	RL-4B	E-4			13.00-2.5	23.1	587	20.0	508	65.2	1656	21.8	554	28.7	730	322	200	271.0	1748	138.7	525.1	68	54	130	190	100	150	80	120	
	RL-4J	E-4	N	A	13.00-2.5	23.1	587	20.3	516	65.4	1661	22.1	561	30.1	765	322	200	250.0	1613	137.1	518.9	68	54	130	190	100	150			
	RL-5K	L-5	N	E	13.00-2.5	23.1	587	20.2	513	65.8	1671	21.9	557	30.6	776	319	198	349.0	2252	119.4	452.0	99	78							
	RL-5S	L-5S	N	E	13.00-2.5	23.1	587	20.2	513	65.8	1671	21.9	557	30.6	776	319	198	349.0	2252	119.4	452.0	99	78							
SM-5A	L-5S			13.00-2.5	23.1	587	20.2	513	65.8	1671	21.9	557	30.6	776	319	198	327.0	2110	119.4	452.0	99	78								

See Wide Base Section for 80 aspect ratio tires (e.g. 59/80R63)

Sizes in bold type can be obtained in locations in bold. Extended lead time may be needed in other locations.

Legend	N = North America L = Latin America	E = Europe / Africa / Mid East A = Asia / Australia	# = Estimated Data * = Tube Type Tire	^ = Work Capability Factor
---------------	--	--	--	----------------------------

LOAD LIMITS AT COLD INFLATION PRESSURES

5 MPH (10 KM/H) MAXIMUM SPEED OFF-THE-ROAD SLOW SPEED SERVICE

RADIAL	PSI	76	80	83	87	91	94	98	102	105	109	112	116	120	131
	KPA	525	550	575	600	625	650	675	700	725	750	775	800	825	900
18.00R25	LBS	24700	26000*	26800	27600	28300	29100	30000	30900	32000	33100	33100	34200	35300**	37500***
	KG	11200	11800*	12150	12500	12850	13200	13600	14000	14500	15000	15000	15500	16000**	17000***

25 MPH (40 KM/H) MAXIMUM SPEED OFF-THE-ROAD TRACTOR AND GRADER SERVICE

RADIAL	PSI	36	40	44	47	51
	KPA	250	275	300	325	350
18.00R25	LBS	9650	10500	11000	11700	12300*
	KG	4375	4750	5000	5300	5600*

30 MPH (50 KM/H) MAXIMUM SPEED OFF-THE-ROAD HAULAGE SERVICE

RADIAL	PSI	65	69	73	76	80	83	87	91	94	98	102
	KPA	450	475	500	525	550	575	600	625	650	675	700
18.00R25	LBS	14800	15700*	16100	16500	17100	17600	18200	18700	19300	19800	20400**
	KG	6700	7100*	7300	7500	7750	8000	8250	8500	8750	9000	9250**

Legend

▲ Permafoam inflation or special rim required

CONVENTIONAL SIZE

DIMENSIONAL DATA

BIAS



ELV-3A ELV-5A SGL D/L-2A SMO-5C SMO-5A SRB-7A HRL-3A

Size	Type	Ind Code	Current In Line Location	Rim Width & Flange	Min. Dual Spacing in mm	INFLATED DIMENSIONS		LOADED DIMENSIONS		Revol Per mi km	Gross Contact Area in ² cm ²		Tire Volume gal ltrs		Tread Depth 1/32 in mm		PERFORMANCE CAPABILITY		
						Overall Width in mm	Overall Diameter in mm	Load Sect & Growth in mm	Static Load Rad in mm		in ²	cm ²	gal	ltrs	in	mm	2S tmph tkph	4S tmph tkph	6S tmph tkph
21.00-25	ELV-3A	IND-3	N	15.00-3.0	26.3 668	22.8 579	69.0 1753	26.1 663	31.2 805	297 185	323.0 2084	174.0 658.0	44 35						
	ELV-5A	IND-5S	N	15.00-3.0	26.3 668	22.8 579	69.0 1753	24.8 630	31.9 810	295 183	336.0 2168		107 85						
	HRL-3A	E-3		15.00-3.0	26.3 668	23.6 599	69.4 1763	26.1 663	31.7 805	297 185	323.0 2084	174.0 658.0	44 35						
	SGL-2A	E-2		15.00-3.0	26.3 668	23.9 607	66.7 1694	26.5 673	29.7 754	316 196	370.0 2387	152.0 576.0	41 33			140 200			
	SMO-5A	L-5S	N	15.00-3.0	26.3 668	22.8 579	69.0 1753	24.8 630	31.9 810	295 183	336.0 2168	140.2 530.9	125 99			^40 ^60			
	SMO-5C	L-5S		A	15.00-3.0	26.3 668	22.8 579	69.0 1753	24.8 630	31.9 810	295 183	336.0 2168	140.2 530.9	125 99		^40 ^60			
	SRB-7A	E-7	N	E	15.00-3.0	26.3 668	23.6 599	66.9 1699	25.5 648	29.3 744	325 202	294.0 1897	206.0 781.0	16 12		185 270			
21.00R25	SR-7A	E-7		15.00-3.0	26.3 688	23.7 604	68.9 1750	26.4 672	31.0 787	305 190	304.0 1963	207.2 784.5	33 27						
22-25	SGL D/L-2A	L-2		14.00-1.5		21.7 551	53.9 1370	23.0 584	24.0 610	396 246	315.0 2032		31 24		60 90				
23/90-25	SMO-5C	L-5S	N	A	15.00-2.5	22.8 579	65.5 1664	24.8 630	30.2 767	312 191	305.0 1968		114 90						
61X18.00-25	R Tow Sv	IND-3		13.00-2.5		19.4 493	61.6 1565	21.3 541	28.0 711	336 209	293.0 1890		40 32	150 219					

See Wide Base Section for 80 aspect ratio tires (e.g. 59/80R63)

Sizes in bold type can be obtained in locations in bold. Extended lead time may be needed in other locations.

Legend	N = North America	E = Europe / Africa / Mid East	# = Estimated Data	^ = Work Capability Factor
	L = Latin America	A = Asia / Australia	* = Tube Type Tire	

LOAD LIMITS AT COLD INFLATION PRESSURES

5 MPH (10 KM/H) MAXIMUM SPEED OFF-THE-ROAD SLOW SPEED SERVICE

	PSI	73	78	80	83	87	91	94	98	102	105	109	112	116	120
BIAS	KPA	500	525	550	575	600	625	650	675	700	725	750	775	800	825
21.00-25	LBS	33100(24)	34200	35300	36400(28)	37500	37500	38600(32)	39700	40800	41900(36)	43000	43000	44100	45400(40)
	KG	15000(24)	15500	16000	16500(28)	17000	17000	17500(32)	18000	18500	19000(36)	19500	19500	20000	20600(40)
RADIAL	PSI	112	80	83	87	91	94	98	102	105	109	116	120	131	
	KPA	775	550	575	600	625	650	675	700	725	750	800	825	900	
21.00R25	LBS	4300	33100*	34200	35300	36400	37500	38600	39700	40800	41900	44100	45400**	48100***	
	KG	19500	15000*	15500	16000	16500	17000	17500	18000	18500	19000	20000	20600**	21800***	
BIAS	PSI	36	40	44	47	51	54								
	KPA	250	275	300	325	350	375								
22-25	LBS	13850	14600(12)	15350	16100	16850	17600(16)								
	KG	6375	6700(12)	7025	7350	7675	8000(16)								
BIAS	PSI	73	78	80	83	87	91	94	98						
	KPA	500	525	550	575	600	625	650	675						
23/90-25	LBS	29100	30000	30900	32000(30)	32000	33100	34200	35300(36)						
	KG	13200	13600	14000	14500(30)	14500	15000	15500	16000(36)						
BIAS	PSI	116	120	123	127	131	134	138	141	145	149	152			
	KPA	800	825	850	875	900	925	950	975	1000	1025	1050			
61X18.00-25	LBS	33100	33100	34200	34200	35300	35300	36400	36400	37500	37500	38600(44)			
	KG	15000	15000	15500	15500	16000	16000	16500	16500	17000	17000	17500(44)			

30 MPH (50 KM/H) MAXIMUM SPEED OFF-THE-ROAD HAULAGE SERVICE

	PSI	40	44	47	51	54	58	62	65	69	73	
BIAS	KPA	275	300	325	350	375	400	425	450	475	500	
21.00-25	LBS	16100	17100	17600	18700	19300(24)	19800	20900(28)	21500	22000	22700(32)	
	KG	7300	7750	8000	8500	8750(24)	9000	9500(28)	9750	10000	10300(32)	
RADIAL	PSI	65	69	73	76	80	83	87	91	94	102	
	KPA	450	475	500	525	550	575	600	625	650	700	
21.00R25	LBS	19800	20400*	20900	22000	22700	23400	24000	25400	26000	26800	27600**
	KG	9050	9250*	9500	10000	10300	10600	10900	11500	11800	12150	12500**
BIAS	PSI	25	29									
	KPA	175	200									
22-25	LBS	7940(12)	9660(16)									
	KG	3600(12)	4380(16)									

40 MPH (65 KM/H) MAXIMUM SPEED OFF-THE-ROAD SAND SERVICE

	PSI	11	15	18	22	25	29	33	36
BIAS	KPA	75	100	125	150	175	200	225	250
21.00-25	LBS	6390	7610	8540	9650	10470	11350	12020	12790
	KG	2900	3450	3875	4375	4750	5150	5450	5800

Legend

▲ Permafoam inflation or special rim required

CONVENTIONAL SIZE

DIMENSIONAL DATA

RADIAL

BIAS



EV-3+ EV-4S EV-S5S EV-S4S GP-4C RL-2F RL-3+ RL-4H RL-4B RL-4J RT-4A ELV-3A ELV-4B ELV-4S HRL-3A HRL-4B MRL-4B

Size	Type	Ind Code	Current In Line Location	Rim Width & Flange	Min. Dual Spacing in mm	INFLATED DIMENSIONS		LOADED DIMENSIONS		Revol Per mi km	Gross Contact Area in ² cm ²	Tire Volume gal ltrs		Tread Depth 1/32 in mm	PERFORMANCE CAPABILITY					
						Overall Width in mm	Overall Diameter in mm	Load Sect & Growth in mm	Static Load Rad in mm			in	ltrs		2S tmph tkph	4S tmph tkph	6S tmph tkph			
18.00-33	ELV-3A	IND-3		13.00-2.5	23.1 587	20.4 518	71.9 1826	22.5 572	33.4 848	282 175	287.0 1852	148.6 562.5	39 31							
	ELV-4B	IND-4	N L A	13.00-2.5	23.1 587	20.3 516	73.4 1864			273 170		146.1 553.0	70 56							
	HRL-3A	E-3	L A	13.00-2.5	23.1 587	20.4 518	71.9 1826	22.5 572	33.4 848	282 175	287.0 1852	148.6 562.5	39 31	150 220	110 160					
	HRL-4B	E-4	N L A	13.00-2.5	23.1 587	20.3 516	73.4 1864	22.2 564	34.4 874	273 170	270.0 1742	146.1 553.0	70 56		100 150	85 120				
18.00R33	EV-3+	IND-3+	N E	13.00-2.5	23.1 587	19.5 495	72.5 1824	21.9 556	33.1 841	293 182	295.0 1903	160.6 607.9	53 42							
	EV-4J #	IND-4	E	13.00-2.5	23.1 587	20.2 513	73.8 1875	22.6 574	34.1 866	285 177	440.0 2841	154.8 586.0	67 53							
	EV-4S	IND-4S		13.00-2.5	23.1 587	19.5 495	71.8 1824	21.9 556	33.1 841	293 182	295.0 1903	160.6 607.9	68 54							
	EV-S4S	IND-4S	E	13.00-2.5	23.1 587	20.6 524	73.5 1868	21.7 551	31.8 808	288 179	430.0 2773		68 54							
	EV-S5S	IND-5S	E	13.00-2.5	23.1 587	20.2 513	73.7 1873		32.7 831	285 177	396.0 2555		114 90							
	GP-4C #	E-4	A	13.00-2.5	23.1 587	20.2 513	73.2 1858	22.2 564	32.7 831	287 178	308.0 1984	175.0 662.0	70 56							
	RL-2F	E-2		13.00-2.5	23.1 587	19.5 495	71.7 1821	21.7 551	32.8 833	293 182	290.0 1871	159.5 603.7	37 29	200 290	150 220					
	RL-3+	E-3+	N E	13.00-2.5	23.1 587	19.5 495	71.8 1824	21.9 556	33.1 841	293 182	295.0 1903	160.6 607.9	53 42	180 260	135 200	110 160				
	RL-4	E-4		13.00-2.5	23.1 587	20.2 513	73.0 1854	21.7 551	33.6 853	288 179	296.0 1910	164.3 621.8	68 54	150 220	115 170	90 130				
	RL-4B	E-4	N A	13.00-2.5	23.1 587	20.0 507	73.2 1858	22.2 564	33.7 856	287 178	310.0 1997	175.0 662.0	68 54	155 230	120 175	90 130				
	RL-4F	E-4		13.00-2.5	23.1 587	20.2 513	73.6 1868	22.6 574	34.0 864	285 177	302.0 1949	160.7 608.2	59 47	140 200	105 150	85 120				
RL-4H	E-4	N A	13.00-2.5	23.1 587	19.7 501	73.7 1871	22.2 563	34.1 866	285 177	290.0 1870	154.7 585.7	68 54	155 230	120 175	90 130					
RL-4J	E-4	N E	13.00-2.5	23.1 587	19.7 501	73.7 1871	22.2 563	34.1 866	285 177	290.0 1870	154.7 585.7	68 54	155 230	120 175	90 130					
RT-4A	E-4	E	13.00-2.5	23.1 587	20.2 513	73.5 1867	22.9 582	32.8 833	286 178	337.0 2175	175.0 662.0	68 54	160 230	125 180	94 140					
21.00R33	RL-4B	E-4	N E A	15.00-3.0	26.3 667	23.8 605	78.3 1988	26.8 681	34.8 884	268 167	435.0 2806	225.0 852.0	68 54	205 300	160 230	127 190				
21.00-35	ELV-4B	IND-4	N	15.00-3.0	27.6 701	24.0 610	80.2 2037	26.2 665	37.2 945	253 157	366.0 2361	213.1 806.6	70 56							
	ELV-4S	IND-4S		15.00-3.0	27.6 701	23.8 605	80.1 2035	26.2 665	37.2 945	253 157	366.0 2361		76 60							
	HRL-3A	E-3		15.00-3.0	27.6 701	23.6 599	78.6 1996	26.0 660	36.5 927	258 160	363.0 2342	198.0 749.0	44 35	200 290	145 210					
	HRL-4B	E-4	N L A	15.00-3.0	27.6 701	24.0 610	80.2 2037	26.2 665	37.2 945	253 157	366.0 2361	213.1 806.6	70 56	180 260	130 190	110 160				
	MRL-4B	E-4		15.00-3.0	27.6 701	23.8 605	80.1 2035	26.2 665	37.2 945	253 157	366.0 2361		76 60		115 170					

See Wide Base Section for 80 aspect ratio tires (e.g. 59/80R63)

Sizes in bold type can be obtained in locations in bold. Extended lead time may be needed in other locations.

Legend	N = North America L = Latin America	E = Europe / Africa / Mid East A = Asia / Australia	# = Estimated Data * = Tube Type Tire	^ = Work Capability Factor
---------------	--	--	--	----------------------------

LOAD LIMITS AT COLD INFLATION PRESSURES

5 MPH (10 KM/H) MAXIMUM SPEED OFF-THE-ROAD SLOW SPEED SERVICE

		69	73	76	80	83	87	91	94	98	102	105	109	120	
BIAS	PSI KPA	475 475	500 500	525 525	550 550	575 575	600 600	625 625	650 650	675 675	700 700	725 725	750 750	825 825	
18.00-33	LBS KG	29100 13200	30000 13600	30900 14000	32000(24) 14500(24)	33100 15000	33100 15000	34200 15500	35300(28) 16000(28)	36400 16500	36400 16500	37500 17000	38600(32) 17500(32)	40800(36) 18600(36)	
21.00-35	LBS KG	38600 17500	39700 18000	40800 18500	41900 19000	43000(28) 19500(28)	44100 20000	45400 20600	46700(32) 21200(32)	46700 21200	48100 21800	49400 22400	50700(36) 23000(36)	53600(40) 24300(40)	
RADIAL	PSI KPA	76 525	80 550	83 575	87 600	91 625	94 650	98 675	102 700	105 725	109 750	112 775	116 800	120 825	131 900
18.00R33	LBS KG	29100 13200	30000* 13600*	30900 14000	32000 14500	33100 15000	34200 15500	35300 16000	36400 16500	36400 16500	37500 17000	38600 17500	39700 18000	40800** 18500**	43000*** 19500***
RADIAL	PSI KPA	76 525	80 550	83 575	87 600	91 625	94 650	98 675	102 700	105 725	109 750	112 775	116 800	120 825	
21.00R33	LBS KG	37500 17000	38600* 17500*	39700 18000	40800 18500	41900 19000	43000 19500	44100 20000	45400 20600	46700 21200	48100 21800	49400 22400	50700 23000	52000** 23600**	

30 MPH (50 KM/H) MAXIMUM SPEED OFF-THE-ROAD HAULAGE SERVICE

		40	44	47	51	54	58	62	65	69	73	76	80	83	87	91	
BIAS	PSI KPA	275 275	300 300	325 325	350 350	375 375	400 400	425 425	450 450	475 475	500 500	525 525	550 550	575 575	600 600	625 625	Continued
18.00-33	LBS KG	14300 6500	15200 6900	16100 7300	16500 7500	17600 8000	18200 8250	18700(24) 8500(24)	19300 8750	19800 9000	20400(28) 9250(28)	21500 9750	22000 10000	22700(32) 10300(32)	22700 10300	23400(36) 10600(36)	
	PSI KPA	94 650	98 675	102 700													
	LBS KG	24000 10900	24700 11200	25400(40) 11500(40)													
RADIAL	PSI KPA	65 450	69 475	73 500	76 525	80 550	83 575	87 600	91 625	94 650	98 675	102 700	105 725	109 750	112 775	116 800	Continued
18.00R33	LBS KG	17100 7750	17600* 8000*	18700 8500	19300 8750	19800 9000	20400 9250	21500 9750	22000 10000	22700 10300	23400 10600	24000** 10900**	24700 11200	25400 11500	26000 11800	26800 12150	
	PSI KPA	120 825															
	LBS KG	26800*** 12150***															
RADIAL	PSI KPA	65 450	69 475	73 500	76 525	80 550	83 575	87 600	91 625	94 650	98 675	102 700					
21.00R33	LBS KG	22000 10000	22700* 10300*	24000 10900	24700 11200	25400 11500	26000 11800	27600 12500	28300 12850	29100 13200	30000 13600	30900** 14000**					
BIAS	PSI KPA	40 275	44 300	47 325	51 350	54 375	58 400	62 425	65 450	69 475	73 500	76 525	80 550	83 575	87 600	91 625	
21.00-35	LBS KG	19300 8750	19800 9000	20900 9500	22000 10000	22700 10300	24000 10900	24700(28) 11200(28)	25400 11500	26000 11800	26800(32) 12150(32)	27600 12500	28300(36) 12850(36)	29100 13200	30000 13600	30900(40) 14000(40)	

Legend ▲ Permafoam inflation or special rim required

CONVENTIONAL SIZE

DIMENSIONAL DATA

RADIAL

BIAS



GT-4B RL-2F RL-3+ RL-4H RL-4B RL-4J RM-4B+ RT-4A+ HRL-3A HRL-4B
 RL-4HII RL-4JII MRL-4B

Size	Type	Ind Code	Current In Line Location	Rim Width & Flange	Min. Dual Spacing in mm	INFLATED DIMENSIONS		LOADED DIMENSIONS		Revol Per mi km	Gross Contact Area in ² cm ²		Tire Volume gal ltrs		Tread Depth 1/32 in mm		PERFORMANCE CAPABILITY					
						Overall Width in mm	Overall Diameter in mm	Load Sect & Growth in mm	Static Load Rad in mm		in ²	cm ²	gal	ltrs	in	mm	2S tmph tkph		4S tmph tkph		6S tmph tkph	
21.00R35	RL-2F	E-2		15.00-3.0	27.6 701	22.9 582	78.4 1991	25.2 640	35.9 912	268 167	380.0 2452	224.4 849.5	40 32									
	RL-3+	E-3+	A	15.00-3.0	27.6 701	23.1 587	79.3 2014	25.7 653	36.3 922	265 165	362.0 2336	231.7 877.1	56 44									
	RL-4B	E-4	N	15.00-3.0	27.6 701	23.6 599	80.2 2036	26.4 670	35.8 908	262 163	399.0 2579	250.0 496.0	70 56									
	RL-4F	E-4		15.00-3.0	27.6 701	23.3 592	80.9 2055	26.1 664	36.9 937	260 162	380.0 2450	231.7 877.1	68 54									
	RL-4H	E-4	N	A	15.00-3.0	27.6 701	23.2 590	80.4 2042	26.7 678	37.0 940	261 162	367.0 2368	242.8 919.1	68 54								
	RL-4HII	E-4	N	A	15.00-3.0	27.6 701	23.2 590	80.4 2042	26.7 678	37.0 940	261 162	367.0 2368	242.8 919.1	68 54								
	RL-4J	E-4	N	E	A	15.00-3.0	27.6 701	80.4 2042	26.7 678	37.0 940	261 162	367.0 2368	239.5 906.6	68 54								
	RL-4JII	E-4			15.00-3.0	27.6 701	23.2 590	80.4 2042	26.7 678	37.0 940	261 162	367.0 2368	239.5 906.6	68 54								
24.00-35	HRL-3A	E-3		17.00-3.5	31.3 795	26.6 676	84.5 2146	29.4 747	38.7 983	243 151	457.0 2949	240.0 910.0	49 39									
	HRL-4B	E-4	N	L	A	17.00-3.5	86.0 2184	29.2 742	39.7 1008	237 147	439.0 2832	223.3 843.0	73 58									
	MRL-4B	E-4	N		A	17.00-3.5	86.4 2195	29.2 742	39.7 1008	237 147	468.0 3019	270.2 1022.6	87 69									
24.00R35	GT-4B #	E-4+		17.00-3.5	31.3 795	27.4 696	86.4 2195	30.5 775	38.8 985	243 151	522.8 3373	325.0 1230.0	84 67									
	RL-2F	E-2		17.00-3.5	31.3 795	26.2 665	83.5 2121	28.8 732	37.9 963	252 156	480.0 3097	300.4 1136.8	46 37									
	RL-3+	E-3+	N	E	17.00-3.5	31.3 795	25.9 658	84.0 2134	29.1 739	250 155	465.0 3001	310.7 1176.2	60 48									
	RL-4B	E-4	N		17.00-3.5	31.3 795	26.9 683	86.4 2205	30.5 774	243 151	531.0 3428	300.0 1136.0	72 57									
	RL-4F	E-4		17.00-3.5	31.3 795	27.5 699	86.0 2184	30.5 775	39.2 996	244 152	480.0 3097	333.9 1263.8	72 57									
	RL-4HII	E-4	N	A	17.00-3.5	31.3 795	27.2 691	86.2 2190	30.1 765	39.5 1003	244 152	477.0 3077	332.9 1260.2	71 56								
	RL-4J	E-4	N	E	17.00-3.5	31.3 795	27.2 691	86.2 2190	30.1 765	39.5 1003	244 152	477.0 3077	332.9 1260.2	71 56								
	RL-4JII	E-4			17.00-3.5	31.3 795	27.2 691	86.2 2190	30.1 765	39.5 1003	244 152	477.0 3077	332.9 1260.2	71 56								
	RM-4B+ #	E-4+		17.00 x 3.5	31.3 794	26.9 683	86.4 2195	30.5 775	38.3 973	243.2 151.1	531.3 3428	300.0 1136.0	89 70									
	RT-4A+	E-4+	N	E	17.00-3.5	31.3 795	26.6 676	85.6 2174	29.6 752	245 153	582.0 3754	300.0 1136.0	90 71									
24.00-43	HRL-4B	E-4		17.00-3.5	31.3 795	26.6 676	94.1 2390	29.3 744	43.6 1107	217 135	520.0 3355	338.0 1279.0	73 58									

See Wide Base Section for 80 aspect ratio tires (e.g. 59/80R63)

Sizes in bold type can be obtained in locations in bold. Extended lead time may be needed in other locations.

Legend	N = North America L = Latin America	E = Europe / Africa / Mid East A = Asia / Australia	# = Estimated Data * = Tube Type Tire	^ = Work Capability Factor
---------------	--	--	--	----------------------------

LOAD LIMITS AT COLD INFLATION PRESSURES

5 MPH (10 KM/H) MAXIMUM SPEED OFF-THE-ROAD SLOW SPEED SERVICE

	PSI	76	80	83	87	91	94	98	102	105	109	112	116	120	
RADIAL	KPA	525	550	575	600	625	650	675	700	725	750	775	800	825	
21.00R35	LBS	38600	39700*	40800	41900	43000	44100	45400	46700	48100	49400	50700	52000	53600**	
	KG	17500	18000*	18500	19000	19500	20000	20600	21200	21800	22400	23000	23600	24300**	
BIAS	PSI	69	73	76	80	83	87	91	94	98	102	105	109		
	KPA	475	500	525	550	575	600	625	650	675	700	725	750		
24.00-35	LBS	49400	50700	52000(30)	53600	55100	56800	58400	58400(36)	60000	61500	64000	64000(42)		
	KG	22400	23000	23600(30)	24300	25000	25750	26500	26500(36)	27250	28000	29000	29000(42)		
RADIAL	PSI	76	80	83	87	91	94	98	102	105	109	112	116	120	131
	KPA	525	550	575	600	625	650	675	700	725	750	775	800	825	900
24.00R35	LBS	48100	50700*	53600	55100	56800	58400	60000	61500	64000	64000	66000	66000	68000**	74000***
	KG	21800	23000*	24300	25000	25750	26500	27250	28000	29000	29000	30000	30000	30750**	33600***

25 MPH (40 KM/H) MAXIMUM SPEED OFF-THE-ROAD TRACTOR AND GRADER SERVICE

	PSI	29	33	36	40	44	47	51	54	58	62	65	69	73	76	80
RADIAL	KPA	200	225	250	275	300	325	350	375	400	425	450	475	500	525	550
21.00R35	LBS	12000	13200	14300	15200	16500	17600	18700*	19300	20400	21500	22000	23400	24000	25400	26000**
	KG	5450	6000	6500	6900	7500	8000	8500*	8750	9250	9750	10000	10600	10900	11500	11800**

30 MPH (50 KM/H) MAXIMUM SPEED OFF-THE-ROAD HAULAGE SERVICE

	PSI	65	69	73	76	80	83	87	91	94	98	102					
RADIAL	KPA	450	475	500	525	550	575	600	625	650	675	700					
21.00R35	LBS	22700	23400*	24700	25400	26000	26800	28300	29100	30000	30900	32000**					
	KG	10300	10600*	11200	11500	11800	12150	12850	13200	13600	14000	14500**					
24.00R35	LBS	29100	30000*	30900	32000	34200	35300	36400	37500	38600	39700	40800**					
	KG	13200	13600*	14000	14500	15500	16000	16500	17000	17500	18000	18500**					
BIAS	PSI	40	44	47	51	54	58	62	65	69	73	76	80	83	87	91	
	KPA	275	300	325	350	375	400	425	450	475	500	525	550	575	600	625	Continued
24.00-35	LBS	24700	26000	26800	28300	29100	30900(30)	32000	33100	34200(36)	34200	35300	36400	37500(42)	38600	39700	
	KG	11200	11800	12150	12850	13200	14000(30)	14500	15000	15500(36)	15500	16000	16500	17000(42)	17500	18000	
	PSI	94															
	KPA	650															
	LBS	40800(48)															
	KG	18500(48)															
BIAS	PSI	69	65	73	76	80	83	87	91	94							
	KPA	475	450	500	525	550	575	600	625	650							
24.00-43	LBS	27500(36)	36400	38600	39700	40800	41900(42)	43000	44100	45400(48)							
	KG	17000(36)	16500	17500	18000	18500	19000(42)	19500	20000	20600(48)							

Legend ▲ Permafoam inflation or special rim required

CONVENTIONAL SIZE

DIMENSIONAL DATA

RADIAL



RL-3+ RL-4 RL-4B RL-4J

BIAS



HRL-3A HRL-4B
MRL-4B

Size	Type	Ind Code	Current In Line Location	Rim Width & Flange	Min. Dual Spacing in mm	INFLATED DIMENSIONS		LOADED DIMENSIONS		Revol Per mi km	Gross Contact Area in ² cm ²	Tire Volume gal ltrs		Tread Depth 1/32 in mm		PERFORMANCE CAPABILITY		
						Overall Width in mm	Overall Diameter in mm	Load Sect & Growth in mm	Static Load Rad in mm			gal	ltrs	in	mm	2S tmph tkph	4S tmph tkph	6S tmph tkph
18.00-49	HRL-3A	E-3		13.00-2.75	24.2 615	20.2 513	88.0 2235	22.7 577	41.2 1046	228 142	338.0 2181	205.0 778.0	39 31		130 190			
	HRL-4B	E-4		13.00-2.75	24.2 615	20.0 508	90.1 2289	22.4 569	42.3 1074	224 139	328.0 2116	188.0 710.0	70 56		115 170			
21.00-49	HRL-3B	E-3		15.00-3.0	27.6 701	23.6 599	93.2 2367	26.5 673	43.3 1100	210 131	453.0 2923	251.0 950.0	46 37		170 250			
	HRL-4B	E-4		15.00-3.0	27.6 701	23.4 594	94.5 2400	25.9 658	44.2 1123	213 132	429.0 2768	247.0 935.0	70 56		160 230			
24.00-49	HRL-3B	E-3	N A	17.00-3.5	31.3 795	26.4 671	98.7 2507	29.7 754	45.3 1151	208 129	573.0 3697	346.0 1309.7	50 40		200 290			
	HRL-4B	E-4	N L A	17.00-3.5	31.3 795	26.2 665	100.1 2543	29.4 747	46.3 1176	203 126	526.0 3394	330.5 1251.0	73 58		190 280	165 240		
	MRL-4B	E-4	N L	17.00-3.5	31.3 795	26.5 673	100.1 2543	29.4 747	46.3 1176	203 126	526.0 3394		87 69		165 240			
	MRL-4D	E-4	L A	17.00-3.5	31.3 795	27.5 699	100.7 2558		47.8 1214				92 73	234 340	175 260			
24.00R49	RL-3+	E-3+	N A	17.00-3.5	31.3 795	26.4 671	97.7 2482	29.1 739	44.6 1133	215 134	581.0 3748	370.2 1401.1	60 48	375 550	280 410			
	RL-4	E-4		17.00-3.5	31.3 795	27.2 691	98.8 2509	29.2 742	45.2 1148	213 132	590.0 3807	382.1 1444.3	72 57		260 380			
	RL-4B	E-4		17.00-3.5	31.3 795	27.0 685	100.2 2543	30.6 777	45.2 1148	210 130	615.0 3968	400.0 1514.0	73 58					
	RL-4J	E-4	N A	17.00-3.5	31.3 795	27.3 693	100.2 2545	30.6 777	46.0 1163	210 130	586.0 3781	403.7 1528.0	73 58	320 470	245 360	190 280	61	
27.00-49	HRL-3B	E-3		19.50-4.0	35.1 893	29.0 737	103.9 2639	32.2 818	47.9 1217	195 121	642.0 4142	430.0 1629.0	55 44		260 380			
	HRL-4B	E-4	N L A	19.50-4.0	35.1 893	29.2 742	105.9 2690	33.1 841	48.4 1229	191 119	645.0 4162	430.4 1629.2	85 67	310 450	235 345	175 255		
	MRL-4D	E-4		19.50-4.0	35.1 893	29.7 754	105.7 2685	33.1 841	49.6 1260	196 122	639.0 4124	430.4 1629.2	95 75		190 280			
	MRL-4F	E-4		19.50-4.0	35.1 893	29.3 744	105.7 2685	33.2 843	48.8 1240	191 119	700.0 4516	450.6 1705.7	86 68					
	SHY-7A	E-7		19.50-4.0	35.1 893	29.6 752	102.9 2614	32.7 831	47.2 1199	198 123	718.0 4633		44 35		325 470			

See Wide Base Section for 80 aspect ratio tires (e.g. 59/80R63)

Sizes in bold type can be obtained in locations in bold. Extended lead time may be needed in other locations.

Legend	N = North America L = Latin America	E = Europe / Africa / Mid East A = Asia / Australia	# = Estimated Data * = Tube Type Tire	^ = Work Capability Factor
---------------	--	--	--	----------------------------

LOAD LIMITS AT COLD INFLATION PRESSURES

5 MPH (10 KM/H) MAXIMUM SPEED OFF-THE-ROAD SLOW SPEED SERVICE

	PSI	69	73	76	80	83	87	91	94	98	102	105	109	
BIAS	KPA	475	500	525	550	575	600	625	650	675	700	725	750	
18.00-49	LBS	37500	38600	39700	40800(24)	41900	41900	43000	44100(28)	45400	46700	46700	48100(32)	
	KG	17000	17500	18000	18500(24)	19000	19000	19500	20000(28)	20600	21200	21200	21800(32)	
21.00-49	LBS	46700	48100	49400	50700	52000	53600	55100	55100(32)	56800	58400	60000	60000(36)	
	KG	21200	21800	22400	23000	23600	24300	25000	25000(32)	25750	26500	27250	27250(36)	
BIAS	PSI	69	73	76	80	83	87	91	94	98	102	105	109	112
	KPA	475	500	525	550	575	600	625	650	675	700	725	750	775
24.00-49	LBS	58400	60000	61500(30)	64000	66000	68000	69500	71500(36)	71500	74000	76000	76000(42)	82700(48)
	KG	26500	27250	28000(30)	29000	30000	30750	31500	32500(36)	32500	33500	34500	34500(42)	37500(48)
27.00-49	LBS	71500	74000	76000	78500	80500(36)	82500	85500	88000	88000(42)	91000	93500	93500	96500(48)
	KG	32500	33500	34500	35500	36500(36)	37500	38750	40000	40000(42)	41250	42500	42500	43750(48)
RADIAL	PSI	76	80	83	87	91	94	98	102	105	109	112	116	120
	KPA	525	550	575	600	625	650	675	700	725	750	775	800	825
24.00R49	LBS	58400	60000*	61500	64000	66000	68000	69500	71500	74000	76000	78500	80500	82500**
	KG	26500	27250*	28000	29000	30000	30750	31500	32500	33500	34500	35500	36500	37500**

30 MPH (50 KM/H) MAXIMUM SPEED OFF-THE-ROAD HAULAGE SERVICE

	PSI	40	44	47	51	54	58	62	65	69	73	76	80	83	
BIAS	KPA	275	300	325	350	375	400	425	450	475	500	525	550	575	
18.00-49	LBS	18200	19300	20400	20900	22000	22700	23400(24)	24700	25400	26000(28)	26800	27600	28300(32)	
	KG	8250	8750	9250	9500	10000	10300	10600(24)	11200	11500	11800(28)	12150	12500	12850(32)	
BIAS	PSI	40	44	47	51	54	58	62	65	69	73	76	80		
	KPA	275	300	325	350	375	400	425	450	475	500	525	550		
21.00-49	LBS	23400	24000	25400	26800	28700	29100	30000	30900	32000	33100(32)	34200	34200(36)		
	KG	10600	10900	11500	12150	12500	13200	13600	14000	14500	15000(32)	15500	15500(36)		
BIAS	PSI	47	51	54	58	62	65	69	73	76	80	83	87	91	94
	KPA	325	350	375	400	425	450	475	500	525	550	575	600	625	650
24.00-49	LBS	32000	34200	35300	36480(30)	37500	39700	40800(36)	41900	43000	44100	45400(42)	46700	48100	48100(48)
	KG	14500	15500	16000	16500(30)	17000	18000	18500(36)	19000	19500	20000	20600(42)	21200	21800	21800(48)
27.00-49	LBS	39700	41900	43000	45400	46700(36)	48100	49400	50700(42)	52000	53600	55100(48)	56800	58400	60000(54)
	KG	18000	19000	19500	20600	21200(36)	21800	22400	23000(42)	23600	24300	25000(48)	25750	26500	27250(54)
RADIAL	PSI	65	69	73	76	80	83	87	91	94	98	102			
	KPA	450	475	500	525	550	575	600	625	650	675	700			
24.00R49	LBS	34200	36400*	37500	38600	40800	41900	43000	44100	45400	46700	48100**			
	KG	15500	16500*	17000	17500	18500	19000	19500	20000	20600	21200	21800**			

Legend ▲ Permafoam inflation or special rim required

CONVENTIONAL SIZE

DIMENSIONAL DATA

RADIAL

BIAS



Size	Type	Ind Code	Current In Line Location	Rim Width & Flange	Min. Dual Spacing in mm	INFLATED DIMENSIONS		LOADED DIMENSIONS		Revol Per mi km	Gross Contact Area in ² cm ²	Tire Volume gal ltrs		Tread Depth 1/32 in mm	PERFORMANCE CAPABILITY					
						Overall Width in mm	Overall Diameter in mm	Load Sect & Growth in mm	Static Load Rad in mm			2S tmph tkph	4S tmph tkph		6S tmph tkph					
27.00R49	GP-2B	E-3	N	19.50-4.0	35.1 893	29.5 749	104.3 2648	33.6 853	47.6 1209	205 127	730.0 4710	52 41	450 660	375 550						
	GP-4B #	E-4	A	19.50-4.0	35.1 893	29.8 756	106.5 2705	33.8 859	47.8 1214	197 123	707.3 4563	82 65	370# 540#	285# 415#	215# 315#					
	GT-4B	E-4+	A	19.50-4.0	35.1 893	30.1 764	106.9 2715	34.0 865	48.4 1230	196.5 122.1	832.0 5368	89 70.6	360 525	275 400	210 305					
	RL-3+	E-3+	N	19.50-4.0	35.1 893	29.6 752	104.2 2647	33.3 846	47.4 1204	202 126	694.0 4477	67 53	375 550	310 450	185 270					
	RL-4	E-4	N	19.50-4.0	35.1 893	29.4 747	105.1 2670	33.6 853	47.9 1217	200 124	694.0 4477	80 64	425 620	335 490						
	RL-4A #	E-4	A	19.50-4.0	35.1 893	29.9 760	106.5 2705	33.7 857	48.5 1232	197 123	732.5 4726	82 65	350# 510#	270# 394#	210# 306#					
	RL-4B	E-4		19.50-4.0	35.1 893	30.2 767	106.4 2703	34.2 868	47.8 1214	198 123	756.0 4879	80 64	375 550	290 420	225 330					
	RL-4H	E-4	N	A	19.50-4.0	35.1 893	29.6 752	106.5 2705	33.4 848	47.8 1214	198 123	704.0 4542	81 64	345 500	265 385	200 295				
	RL-4J	E-4	N	A	19.50-4.0	35.1 893	29.6 752	106.3 2700	33.4 848	48.7 1237	198 123	704.0 4543	81 64	375 545	300 440	180 265				
	RL-4JII	E-4	N	A	19.50-4.0	35.1 893	29.6 752	106.3 2700	33.4 848	48.7 1237	198 123	704.0 4543	81 64	375 545	300 440	180 265				
	RM-4A+	E-4+	N L E A		19.50-4.0	35.1 893	29.8 758	106.2 2697	33.9 861	48.7 1238	198 123	852.0 5500	96 75	410 600	320 465	250 360				
RT-4A+	E-4+	N		19.50-4.0	35.1 893	29.3 744	106.2 2698	33.0 839	47.7 1211	198 123	787.0 5079	95 75	410 600	320 465	250 360					
30.00-51	ELV-4B	IND-4	L	22.00-4.5		33.1 841	113.3 2878	37.0 940	51.9 1318	180 112	867.0 5594	98 78	255 375							
	HRL-4B	E-4	N L	22.00-4.5	39.1 993	33.1 841	113.3 2878	37.0 940	51.9 1318	180 112	867.0 5594	98 78	265 390							
	MRL-4B	E-4		22.00-4.5	39.1 993	33.0 838	114.3 2903	37.0 940	51.9 1318	180 112	867.0 5594	109 87	245 360							
	MRL-4E #	E-4		22.00-4.5	39.1 993	33.0 838	114.7 2913	37.0 940	51.9 1318	180 112	865.0 5581	109 87								
30.00R51	RL-4H	E-4	N	A	22.00-4.5	39.1 993	33.7 856	115.6 2936	38.3 973	52.5 1334	856.0 5524	88 70	450 655	340 495	205 295					
	RL-4JII	E-4		22.00-4.5	39.1 993	34.0 864	115.1 2924	38.3 973	52.5 1334	182 113	856.0 5524	88 70	410 600	310 450	185 270					
33.00-51	HRL-4B	E-4	N L	A	24.00-5.0	42.3 1074	35.6 904	120.2 3053	40.0 1016	54.7 1389	965.0 6226	104 83	395 575	300 440						

See Wide Base Section for 80 aspect ratio tires (e.g. 59/80R63)

Sizes in bold type can be obtained in locations in bold. Extended lead time may be needed in other locations.

Legend	N = North America L = Latin America	E = Europe / Africa / Mid East A = Asia / Australia	# = Estimated Data * = Tube Type Tire	^ = Work Capability Factor
---------------	--	--	--	----------------------------

LOAD LIMITS AT COLD INFLATION PRESSURES

5 MPH (10 KM/H) MAXIMUM SPEED OFF-THE-ROAD SLOW SPEED SERVICE

RADIAL	PSI KPA	76 525	80 550	83 575	87 600	91 625	94 650	98 675	102 700	105 725	109 750	112 775	116 800	120 825
27.00R49	LBS	71500	74000*	76000	78500	82500	85500	85500	88000	91000	93500	96500	99000	99000**
	KG	32500	33500*	34500	35500	37500	38750	38750	40000	41250	42500	43750	45000	45000**
30.00R51	LBS	88000	91000*	93500	99000	100000	104500	107500	110000	113500	117000	120000	120000	123500**
	KG	40000	41250*	42500	45000	46250	47500	48750	50000	51500	53000	54500	54500	56000**
BIAS	PSI	69	73	76	80	83	87	91	94	98	102	105	109	109
	KPA	475	500	525	550	575	600	625	650	675	700	725	750	750
30.00-51	LBS	88000	91000	93500	96500	99000	102000	104500	107500(46)	110000	113500	113500	117000(52)	
	KG	40000	41250	42500	43750	45000	46250	47500	48750(46)	50000	51500	51500	53000(52)	
33.00-51	LBS	104500	107500	110000	113500	117000	120000	120000	123500(50)	128000	128000	132500	135500(58)	
	KG	47500	48750	50000	51500	53000	54500	54500	56000(50)	58000	58000	60000	61500(58)	

30 MPH (50 KM/H) MAXIMUM SPEED OFF-THE-ROAD HAULAGE SERVICE

RADIAL	PSI KPA	65 450	69 475	73 500	76 525	80 550	83 575	87 600	91 625	94 650	98 675	102 700		
27.00R49	LBS	43000	44100*	45400	48100	49400	50700	52000	55100	56800	58400	60000**		
	KG	19500	20000*	20600	21800	22400	23000	23600	25000	25750	26500	27250**		
30.00R51	LBS	52000	55100*	56800	58400	61500	64000	66000	68000	69500	71500	74000**		
	KG	23600	25000*	25750	26500	28000	29000	30000	30750	31500	32500	33500**		
BIAS	PSI	40	44	47	51	54	58	62	65	69	73	76	80	
	KPA	275	300	325	350	375	400	425	450	475	500	525	550	
30.00-51	LBS	44100	46700	49400	50700	53600	55100	56800	60000	61500	64000(46)	64000	66000(52)	
	KG	20000	21200	22400	23000	24300	25000	25750	27250	28000	29000(46)	29000	30000(52)	
BIAS	PSI	40	44	47	51	54	58	62	65	69	73	76	80	83
	KPA	275	300	325	350	375	400	425	450	475	500	525	550	575
33.00-51	LBS	52000	53600	56800	60000	61500	64000	66000	69500	71500	74000(50)	76000	78500	78500(58)
	KG	23600	24300	25750	27250	28000	29000	30000	31500	32500	33500(50)	34500	35500	35500(58)

Legend ▲ Permafoam inflation or special rim required

CONVENTIONAL SIZE

DIMENSIONAL DATA

RADIAL

BIAS



GP-4B RL-3+ RL-4H RL-4C RL-3J RL-4M+ RL-3 RM-4A+ NRL D/L-5A SRB-7A HRL-4D HRL-4B MRL-4B

Size	Type	Ind Code	Current In Line Location	Rim Width & Flange	Min. Dual Spacing in mm	INFLATED DIMENSIONS		LOADED DIMENSIONS		Revol Per mi km	Gross Contact Area in ² cm ²	Tire Volume gal ltrs		Tread Depth 1/32 in mm	PERFORMANCE CAPABILITY					
						Overall Width in mm	Overall Diameter in mm	Load Sect & Growth in mm	Static Load Rad in mm			in	ltrs		2S tmph tkph	4S tmph tkph	6S tmph tkph			
33.00R51	GP-4B	E-4	A	24.00-5.0	42.3 1074	37.1 942	120.6 3063	41.9 1064	54.7 1389	173 107	1014.0 6542	881.1 3334.9	98 78	490 715	370 540	260 380				
	RC-1A #	E-4		24.00-5.0		37.0 940	119.0 3025	42.0 1067	53.0 1350	176 110	1046.0 6745	850.0 3218.0	101 80							
	RL-3J	E-3	N	A	24.00-5.0	42.3 1074	36.5 927	118.7 3015	41.6 1057	53.7 1364	970.0 6258	892.7 3378.8	63 50	620 900	480 700	290 430				
	RL-4C	E-4		A	24.00-5.0	42.3 1074	37.1 942	120.6 3063	41.9 1064	54.7 1389	1014.0 6542	881.1 3334.9	98 78	470 685	360 525	250 365				
	RL-4H	E-4	N	A	24.00-5.0	42.3 1074	36.7 932	120.6 3063	41.4 1052	54.4 1382	975.0 6290	897.4 3396.7	95 76	470 685	360 525	250 365				
	RL-4HII	E-4	N		24.00-5.0	42.3 1074	37.1 942	120.6 3063	41.9 1064	54.7 1389	1014.0 6542	897.4 3396.7	95 76	470 685	360 525	250 365				
	RL-4JII	E-4	N		24.00-5.0	42.3 1074	37.1 942	120.6 3063	41.9 1064	54.7 1389	1014.0 6542	881.1 3334.9	95 76	520 755	395 575	270 395				
	RL-4M+ #	E-4+		A	24.00-5.0	42.3 1074	36.4 925	120.6 3063	41.9 1064	54.9 1395	1197.0 7723	882.0 3339.0	112 89	540 785	410 595	290 420				
36.00-51	RM-4A+ #	E-4+	N L E A	24.00-5.0	42.3 1074	37.1 942	120.6 3063	42.1 1070	53.7 1365	174 108	1046.0 6745	804.0 3043.0	110 88	540# 785#	410# 595#	285# 415#				
	HRL-3B	E-3		26.00-5.0	46.6 1184	40.0 1016	127.5 3246	44.1 1120	55.3 1405	169 105	1070.0 6903		70 56		370 540					
	HRL-4B	E-4	N L	26.00-5.0	46.6 1184	40.0 1016	127.8 3246	43.9 1115	58.8 1494	159 99	1128.0 7278	948.0 3588.5	112 89	465 680	335 490					
	HRL-4D	E-4	N L	26.00-5.0	46.6 1184	38.7 984	125.6 3190			154 96	1127.0 7271		127 103	450 660						
	MRL-4B	E-4		26.00-5.0	46.6 1184	40.0 1016	127.8 3246	43.9 1115	58.8 1494	159 99	1128.0 7278		118 93		325 470					
36.00R51	SRB-7A	E-7		26.00-5.0	46.6 1184	39.9 1013	121.0 3073	44.6 1133	52.8 1341	177 110	1223.0 7890	979.0 3708.0	37 29		430 630					
	RL-3	E-3	N	A	26.00-5.0	46.6 1184	39.7 1008	125.0 3175	45.1 1146	56.2 1427	1156.0 7459	1075.3 4070.1	73 58	685 1000	515 750	375 545				
	RL-3+	E-3+		26.00-5.0	46.6 1184	39.7 1008	125.0 3175	45.1 1146	56.2 1427	163 104	1156.0 7459	1075.3 4070.1	86 68	525 770	450 660	270 390				
	RL-4H	E-4	N	A	26.00-5.0	46.6 1184	40.6 1031	128.4 3261	45.7 1161	57.8 1468	1168.0 7535	1134.7 4294.8	108 85	565 825	490 715	300 435				
67-51	RL-4JII	E-4	N	A	26.00-5.0	46.6 1184	40.8 1036	128.4 3261	46.0 1168	57.8 1468	1168.0 7535	1134.7 4294.8	108 85	515 750	445 650	270 390				
	NRL D/L-5A	L-5		45.00-5.5		65.6 1666	137.7 3498	72.0 1829	60.2 1529	155 96	2450.015807	1538.0 5820.0	172 137							
39/90R53	RL-4H	E-4		26.00-4.0	46.6 1184	40.7 1034	128.3 3260	45.8 1163	57.8 1468	164 102	1170.0 7548	1115.2 4215.4	108 85	540 790	410 600					

See Wide Base Section for 80 aspect ratio tires (e.g. 59/80R63)

Sizes in bold type can be obtained in locations in bold. Extended lead time may be needed in other locations.

Legend	N = North America L = Latin America	E = Europe / Africa / Mid East A = Asia / Australia	# = Estimated Data * = Tube Type Tire	^ = Work Capability Factor
---------------	--	--	--	----------------------------

LOAD LIMITS AT COLD INFLATION PRESSURES

5 MPH (10 KM/H) MAXIMUM SPEED OFF-THE-ROAD SLOW SPEED SERVICE

		76	80	83	87	91	94	98	102	105	109	112	116	120
RADIAL		525	550	575	600	625	650	675	700	725	750	775	800	825
33.00R51	LBS	102000	107500*	110000	113500	117000	120000	123500	128000	132500	132500	139000	139000	143500**
	KG	46250	48750*	50000	51500	53000	54500	56000	58000	60000	60000	63000	63000	65000**
36.00R51	LBS	123500	128000*	132500	139000	143500	147500	152000	156500	161000	165500	165500	171000	176500**
	KG	56000	58000*	60000	63000	65000	67000	69000	71000	73000	75000	75000	77500	80000**
39/90R53	LBS	123500	128000*	132500	139000	143500	147500	152000	156500	161000	165500	165500	171000	176500**
	KG	56000	58000*	60000	63000	65000	67000	69000	71000	73000	75000	75000	77500	80000**
BIAS	PSI	69	73	76	80	83	87	91	94	98				
	KPA	475	500	525	550	575	600	625	650	675				
36.00-51	LBS	128000(42)	128000	132500	139000	143500	143500(50)	147500	153000	156500(58)				
	KG	58000(42)	58000	60000	63000	65000	65000(50)	67000	69000	71000(58)				
BIAS	PSI	47	51	54	58	62	65	69	73	76	80	83	87	
	KPA	325	350	375	400	425	450	475	500	525	550	575	600	
67-51	LBS	156500	165500	171000	176500	187500	193000(54)	198500	204000	209500	215000	220500	227000	
	KG	71000	75000	77500	80000	85000	87500(54)	90000	92500	95000	97500	100000	103000	

30 MPH (50 KM/H) MAXIMUM SPEED OFF-THE-ROAD HAULAGE SERVICE

		65	69	73	76	80	83	87	91	94	98	102	105	109	112	116
RADIAL		450	475	500	525	550	575	600	625	650	675	700	725	750	775	800
33.00R51	LBS	60000	64000*	66000	68000	71500	74000	76000	78500	80500	82500	85500**	88000	88000	91000	93500***
	KG	27250	29000*	30000	30750	32500	33500	34500	35500	36500	37500	38750**	40000	40000	41250	42500***
BIAS	PSI	40	44	47	51	54	58	62	65	69	73	76				
	KPA	275	300	325	350	375	400	425	450	475	500	525				
36.00-51	LBS	61500	66000	69500	71500	76000(42)	78500	80500	82500(50)	85500	88000	91000(58)				
	KG	28000	30000	31500	32500	34500(42)	35500	36500	37500(50)	38750	40000	41250(58)				
RADIAL	PSI	65	69	73	76	80	83	87	91	94	98	102				
	KPA	450	475	500	525	550	575	600	625	650	675	700				
36.00R51	LBS	74000	78500*	80500	82500	85500	88000	91000	93500	96500	99000	102000**				
	KG	33500	35500*	36500	37500	38750	40000	41250	42500	43750	45000	46250**				
39/90R53	LBS	74000	78500*	80500	82500	85500	88000	91000	93500	96500	99000	102000**				
	KG	33500	35500*	36500	37500	38750	40000	41250	42500	43750	45000	46250**				

40 MPH (65 KM/H) MAXIMUM SPEED OFF-THE-ROAD SAND SERVICE

		11	15	18	22	25	29	33	36
BIAS		75	100	125	150	175	200	225	250
36.00-51	LBS	24700	29100	33100	37500	40800	44100	46700	50700
	KG	11200	13200	15000	17000	18500	20000	21200	23000

Legend

▲ Permafoam inflation or special rim required

CONVENTIONAL SIZE

DIMENSIONAL DATA

RADIAL

BIAS



GP-4C RL-3A RL-4A
RL-4H
RL-4HII RL-4B RL-4C RL-4JII RL-4M+ RM-4B+ RM-4A+ HRL-4B

Size	Type	Ind Code	Current In Line Location	Rim Width & Flange	Min. Dual Spacing in mm	INFLATED DIMENSIONS		LOADED DIMENSIONS		Revol Per mi km	Gross Contact Area in ² cm ²	Tire Volume gal ltrs		Tread Depth 1/32 in mm	PERFORMANCE CAPABILITY					
						Overall Width in mm	Overall Diameter in mm	Load Sect & Growth in mm	Static Load Rad in mm			2S tmph tkph	4S tmph tkph		6S tmph tkph					
37.00R57	GP-4C #	E-4	A	27.00-6.0	48.5 1232	42.5 1080	135.8 3449	44.3 1125	61.5 1562	155 96	1350.0 8710	1275.0 4825.9	112 89	615# 900#	460# 670#	295# 430#				
	RL-4C	E-4	A	27.00-6.0	48.5 1232	42.5 1080	135.8 3449	44.3 1125	61.5 1562	155 96	1350.0 8710	1275.0 4825.9	112 89	550 800	415 605	265 390				
	RL-4H	E-4	N A	27.00-6.0	48.5 1232	42.2 1072	135.5 3442	47.5 1207	60.9 1547	155 96	1285.0 8290	1298.8 4916.1	108 85	655 960	490 715	315 460				
	RL-4HII	E-4	N A	27.00-6.0	48.5 1232	42.1 1069	135.8 3449	47.1 1196	61.6 1565	155 96	1345.0 8678	1298.8 4916.1	108 85	550 800	410 600	245 360				
	RL-4JII	E-4	N A	27.00-6.0	48.5 1232	42.1 1069	135.8 3449	47.1 1196	61.6 1565	155 96	1345.0 8678	1298.8 4916.1	108 85	620 900	480 700	290 420				
	RL-4M+	E-4+	N A	27.00-6.0 29.00-6.0	48.5 1232	42.5 1080	135.8 3449	49.3 1252	61.5 1562	155 96	1500.0 9677	1450.0 5489.0	124 98	770 1125	590 860	350 515				
40.00-57	HRL-4B	E-4	N L E A	27.00-6.0	47.9 1216	42.2 1072	136.5 3467	48.0 1220	60.8 1545	154 96	1353.0 8729	1212.0 4588.0	124 98	770# 1125#	590# 860#	350# 515#				
				29.00-6.0	47.9 1216	42.2 1072	136.5 3467	48.0 1220	60.8 1545	154 96	1353.0 8729	1212.0 4588.0	124 98	770# 1125#	590# 860#	350# 515#				
40.00R57	RL-3A	E-3		29.00-6.0	53.1 1349	44.2 1124	140.5 3569	51.4 1306	62.4 1585	150 93	1460.0 9419	1488.3 5633.0	80 63	785 1150	600 870	355 520				
	RL-4A	E-4		29.00-6.0	53.1 1349	44.2 1124	140.5 3569	51.4 1306	62.4 1585	150 93	1488.3 5633.0	1488.3 5633.0	108 85	785 1150	600 870	355 520				
	RL-4B	E-4	N A	29.00-6.0	53.1 1349	44.5 1130	140.5 3569	50.7 1287	62.4 1585	150 93	1611.010394	1488.3 5633.0	108 85	865 1260	660 965	390 570				
	RL-4H	E-4		29.00-6.0	53.1 1349	44.5 1130	140.5 3569	50.7 1287	62.4 1585	150 93	1488.3 5633.0	1488.3 5633.0	108 85	785 1150	600 870	355 520				
	RM-4B+ #	E-4+	N L E A	29.00-6.0	53.1 1348	44.9 1142	140.7 3573	51.2 1302	63.0 1604	149.3 92.8	1600.010323	1475.0 5583.0	124 98	890# 1300#	675# 980#	395# 580#				
45R57	Two Piece Assembly	E-4		29.00-6.0	55.4 1406	46.2 1173	139.8 3551	51.6 1311	63.5 1613	150 93	1640.010581	1500.0 5678.0	110 87	785 1150	600 870	360 530				
46/90R57	RL-4B	E-4	N	32.00-6.0	56.3 1429	47.2 1199	140.8 3576	54.3 1379	63.0 1600	150 93	1925.012419	1575.0 5962.0	108 85	910 1325	690 1010	410 595				
	RM-4A+	E-4+	N L E A	29.00-6.0	57.0 1448	46.2 1174	140.8 3576	52.6 1336	62.5 1588	149 93	1742.011237	1500.0 5678.0	124 98	980 1430	750 1090	440 645				
	RM-4B+	E-4+	N L E A	29.00-6.0	57.0 1447	46.2 1174	140.8 3576	52.7 1339	63.0 1600	149.3 92.8	1725.011129	1470.0 5565.0	124 98	935 1360	710 1040	415 600				

See Wide Base Section for 80 aspect ratio tires (e.g. 59/80R63)

Sizes in bold type can be obtained in locations in bold. Extended lead time may be needed in other locations.

Legend	N = North America L = Latin America	E = Europe / Africa / Mid East A = Asia / Australia	# = Estimated Data * = Tube Type Tire	^ = Work Capability Factor
---------------	--	--	--	----------------------------

LOAD LIMITS AT COLD INFLATION PRESSURES

5 MPH (10 KM/H) MAXIMUM SPEED OFF-THE-ROAD SLOW SPEED SERVICE

RADIAL	PSI	76	80	83	87	91	94	98	102	105	109	112	116	120
	KPA	525	550	575	600	625	650	675	700	725	750	775	800	825
37.00R57	LBS	132500	135500*	139000	143500	147500	152000	156500	161000	165500	171000	176500	176500	182000**
	KG	60000	61500*	63000	65000	67000	69000	71000	73000	75000	77500	80000	80000	82500**
40.00R57	LBS	161000	165500*	171000	176500	182000	187500	193000	198500	204000	209400	215000	220500	220500**
	KG	73000	75000*	77500	80000	82500	85000	87500	90000	92500	95000	97500	100000	100000**
45R57	LBS	161000	165500*	171000	176500	182000	187500	193000	198500	204000	209400	215000	220500	220500**
	KG	73000	75000*	77500	80000	82500	85000	87500	90000	92500	95000	97500	100000	100000**
46/90R57	LBS	165500	171000*	176500	182000	187500	193000	198500	204000	209400	215000	220500	220500	227000**
	KG	75000	77500*	80000	82500	85000	87500	90000	92500	95000	97500	100000	100000	103000**
	PSI	69	73	76	80	83	87	91	94	98	102	105		
BIAS	KPA	475	500	525	550	575	600	625	650	675	700	725		
40.00-57	LBS	161000	165500	171000	176500	182000	182000	187500	193000(60)	198500	204000	204000(68)		
	KG	73000	75000	77500	80000	82500	82500	85000	87500(60)	90000	92500	92500(68)		

30 MPH (50 KM/H) MAXIMUM SPEED OFF-THE-ROAD HAULAGE SERVICE

RADIAL	PSI	65	69	73	76	80	83	87	91	94	98	102		
	KPA	450	475	500	525	550	575	600	625	650	675	700		
37.00R57	LBS	82500	85500*	88000	91000	96500	99000	102000	104500	107500	110000	113500**		
	KG	37500	38750*	40000	41250	43750	45000	46250	47500	48750	50000	51500**		
40.00R57	LBS	93500	99000*	102000	107500	110000	113500	117000	120000	123500	128000	132500**		
	KG	42500	45000*	46250	48750	50000	51500	53000	54500	56000	58000	60000**		
	PSI	40	44	47	51	54	58	62	65	69	73	76	80	
BIAS	KPA	275	300	325	350	375	400	425	450	475	500	525	550	
40.00-57	LBS	80500	85500	88000	91000	96500	99000	102000	107500	110000(60)	113500	117000	120000(68)	
	KG	36500	38750	40000	41250	43750	45000	46250	48750	50000(60)	51500	53000	54500(68)	
	PSI	65	69	73	76	80	83	87	91	94	98	102	105	109
RADIAL	KPA	450	475	500	525	550	575	600	625	650	675	700	725	750
45R57	LBS	93500	99000*	102000	107500	110000	113500	117000	120000	123500	128000	132500	135500	139000**
	KG	42500	45000*	46250	48750	50000	51500	53000	54500	56000	58000	60000	61500	63000**
46/90R57	LBS	99000	104500*	107500	113500	117000	120000	123500	128000	132500	135500	139000**		
	KG	45000	47500*	48750	51500	53000	54500	56000	58000	60000	61500	63000**		

<u>Legend</u>	▲ Permafoam inflation or special rim required
---------------	---

WIDE BASE SIZE

BIAS



DIMENSIONAL DATA

Size	Type	Ind Code	Current In Line Location	Rim Width & Flange	INFLATED DIMENSIONS		LOADED DIMENSIONS		Revol Per mi km	Gross Contact Area in ² cm ²	Tire Volume gal ltrs	Tread Depth 1/32 in mm	PERFORMANCE CAPABILITY		
					Overall Width in mm	Overall Diameter in mm	Load Sect & Growth in mm	Static Load Rad in mm					2S tmph tkph	4S tmph tkph	6S tmph tkph
8.25-15NHS	American Miner SLHD	IND-3	N	6.5x15	9.4 238	33.3 845						25 19			
12.5/80-18	American Backhoe F	R-4	N L E A	W9, W10	12.5 318	38.6 980						37 29			
10.5-20MPT	IND SG			9	10.9 276	37.6 955		17.5 444	549 341						
12.5-20MPT	IND SG			11	12.9 330	40.9 1040		18.9 480	508 316						
27.25-21	* SAW-7A	E-7		19.50-1.5	26.9 683	59.4 1509	28.0 711	25.7 653	371 231	378.0 2439		34 27			
	* SRB-7A	E-7		19.50-1.5	26.9 683	59.4 1509	28.0 711	25.7 653	371 231	378.0 2439		19 15			

Sizes in bold type can be obtained in locations in bold. Extended lead time may be needed in other locations.

Legend	N = North America L = Latin America	E = Europe / Africa / Mid East A = Asia / Australia	# = Estimated Data * = Tube Type Tire	^ = Work Capability Factor
---------------	--	--	--	----------------------------

LOAD LIMITS AT COLD INFLATION PRESSURES

5 MPH (10 KM/H) MAXIMUM SPEED OFF-THE-ROAD SAND SERVICE

BIAS	PSI	11	15	18	22	25	29	33	36
	KPA	75	100	125	150	175	200	225	250
27.25-21	LBS	10200	12020	13890	15210	17090	18190	19290	20940
	KG	4625	5450	6300	6900	7750	8250	8750	9500

25 MPH (40 KM/H) MAXIMUM SPEED OFF-THE-ROAD INDUSTRIAL TRACTOR SERVICE

BIAS	PSI	26	29	32	36	41	44	48	51	54
	KPA	180	200	220	250	280	300	330	350	375
10.5-20MPT	LBS	2920	3020	3150	3550(6)	3780	3935(8)	3980	4365	4560(10)
	KG	1325	1370	1430	1610(6)	1715	1785(8)	1800	1980	2070(10)
12.5-20MPT	LBS	3460	3690	3890	4210	4495	4660(10)	4915	5070(12)	
	KG	1570	1675	1765	1910	2040	2125(10)	2230	2300(12)	

25 MPH (40 KM/H) 25mph (40km/h) Drive Wheel Industrial Tractor

BIAS	PSI	45	45
	KPA	310	310
12.5/80-18	LBS	3740(10 R4)	5360(10 I3)
	KG	1700(10 R4)	2430(10 I3)

40 MPH (65 KM/H) MAXIMUM SPEED OFF-THE-ROAD SAND SERVICE

BIAS	PSI	11	15	18	22	25	29	33	36
	KPA	75	100	125	150	175	200	225	250
27.25-21	LBS	6390	7610	8820	9650	10750	11350	12350	13230
	KG	2900	3450	4000	4375	4875	5150	5600	6000

Legend

▲ Permafoam inflation or special rim required

WIDE BASE SIZE

WIDE BASE SIZE

RADIAL

BIAS



DIMENSIONAL DATA

Size	Type	Ind Code	Current In Line Location	Rim Width & Flange	INFLATED DIMENSIONS				LOADED DIMENSIONS				Gross Contact Area		Tire Volume		Tread Depth 1/32 in mm	PERFORMANCE CAPABILITY							
					Overall Width in mm		Overall Diameter in mm		Load Sect & Growth in mm		Static Load Rad in mm		mi	km	in2	cm2		gal	ltrs	2S		4S		6S	
15.5-25	HRL D/L-3A	G-3	E A	12.00-1.3	15.7	399	50.2	1275	17.7	441	22.7	577	415	258	150.0	968	51.0	191.0	33	26					
	HRL D/L-3A	L-3	N E A	12.00-1.3	15.7	399	50.2	1275	17.7	450	22.4	569	425	264	214.0	1381	51.0	191.0	33	26					
	SGL D/L-2A	G-2	N L E A	12.00-1.3	15.7	399	49.4	1255	17.3	439	22.4	569	421	262	170.0	1097	47.0	179.0	30	24					
	SGL D/L-2A	L-2	N L E A	12.00-1.3	15.7	399	49.4	1255	17.6	447	21.5	546	442	275	206.0	1320	47.0	179.0	30	24					
15.5R25	GP-2B	E-3	N A	12.00-1.3	15.6	396	50.3	1278	17.6	447	22.8	580	419	260	198.0	1277	67.1	253.9	30	24					
	GP-2B	G-3		12.00-1.3	15.6	396	50.3	1278	17.6	447	22.8	580	419	260	149.0	961	67.1	253.9	30	24					
	GP-2B	L-3	N A	12.00-1.3	15.6	396	50.3	1278	17.6	447	22.8	580	419	260	198.0	1277	67.1	253.9	30	24					
	RL-2F	E-2		12.00-1.3	15.4	391	50.6	1285	17.6	447	22.6	573	415	257	200.0	1295	60.5	229.1	29	23	100	150	75	110	
	RL-2F	G-2		12.00-1.3	15.4	391	50.6	1285	17.6	447	22.6	573	415	257	151.0	974	60.5	229.1	29	23					
	RL-2F	L-2		12.00-1.3	15.4	391	50.6	1285	17.6	447	22.6	573	415	257	200.0	1295	60.5	229.1	29	23			60	90	55

Sizes in bold type can be obtained in locations in bold. Extended lead time may be needed in other locations.

Legend	N = North America L = Latin America	E = Europe / Africa / Mid East A = Asia / Australia	# = Estimated Data * = Tube Type Tire	^ = Work Capability Factor
---------------	--	--	--	----------------------------

LOAD LIMITS AT COLD INFLATION PRESSURES

5 MPH (10 KM/H) MAXIMUM SPEED OFF-THE-ROAD SLOW SPEED SERVICE

	PSI	33	36	40	44	47	51	54	58								
BIAS	KPA	225	250	275	300	325	350	375	400								
15.5-25	LBS	8800	9350(8)	9900	10500	10700(10)	11400	11700	12300(12)								
	KG	4000	4250(8)	4500	4750	4875(10)	5150	5300	5600(12)								
	PSI	29	33	36	40	44	47	51	54	58	62	65	69	73	76	80	
RADIAL	KPA	200	225	250	275	300	325	350	375	400	425	450	475	500	525	550	Continued
15.5R25	LBS	6600	7150	7600	8250	8800	9350	9900	10500	11000	11400	12000	12300	12800*	13600	13900	
	KG	3000	3250	3450	3750	4000	4250	4500	4750	5000	5150	5450	5600	5800*	6150	6300	
	PSI	83	87	91	94												
	KPA	575	600	625	650												
	LBS	14300	14800	15200	15700**												
	KG	6500	6700	6900	7100**												

25 MPH (40 KM/H) MAXIMUM SPEED OFF-THE-ROAD TRACTOR AND GRADER SERVICE

	PSI	22	25	29	33	36					
BIAS	KPA	150	175	200	225	250					
15.5-25	LBS	4300(8)	4800(10)	5200	5520	5840(12)					
	KG	1950(8)	2180(10)	2360	2580	2650(12)					
RADIAL	PSI	25	29	33	36	40	44				
	KPA	175	200	225	250	275	300				
15.5R25	LBS	4400	4800	5200	5680	6150	6600*				
	KG	2000	2180	2360	2575	2800	3000*				

30 MPH (50 KM/H) MAXIMUM SPEED OFF-THE-ROAD HAULAGE SERVICE

	PSI	25	29	33	36										
BIAS	KPA	175	200	225	250										
15.5-25	LBS	5680(8)	6150	6600	7150(12)										
	KG	2575(8)	2800	3000	3250(12)										
RADIAL	PSI	40	44	47	51	54	58	62	65	69	73	76			
	KPA	275	300	325	350	375	400	425	450	475	500	525			
15.5R25	LBS	6150	6600	6950	7400	7850*	8050	8550	8800	9350	9650	9900**			
	KG	2800	3000	3150	3350	3550*	3650	3875	4000	4250	4375	4500**			

Legend

▲ Permafoam inflation or special rim required

WIDE BASE SIZE

WIDE BASE SIZE

DIMENSIONAL DATA

BIAS



Size	Type	Ind Code	Current In Line Location	Rim Width & Flange	INFLATED DIMENSIONS		LOADED DIMENSIONS		Revol Per mi km	Gross Contact Area		Tire Volume		Tread Depth		PERFORMANCE CAPABILITY							
					Overall Width in mm	Overall Diameter in mm	Load Sect in mm	Static Load Rad in mm		in2	cm2	gal	ltrs	1/32 in	mm	2S		4S		6S			
																tmph	tkph	tmph	tkph	tmph	tkph		
17.5-25	GRL D/L-3A #	G-3		14.00-1.5	17.7	450	52.6	1336						32	25								
	GRL D/L-3A #	L-3		14.00-1.5	17.7	450	52.6	1336	18.8	478	24.1	612		32	25								
	HRL D/L-3A	G-3	N L E A	14.00-1.5	17.7	450	53.3	1354	20.2	513	23.5	597	404	251	266.0	2080	70.0	264.9	35	28			
	HRL D/L-3A	L-3	N L E A	14.00-1.5	17.7	450	53.3	1354	20.2	513	23.5	597	404	251	322.0	2080	70.0	264.9	35	28			
	SGL D/L-2A	G-2	N L E A	14.00-1.5	17.9	455	52.7	1339	19.7	500	23.0	584	396	246	195.0	1258	66.7	252.3	31	25			
	SGL D/L-2A	L-2	N L E A	14.00-1.5	18.0	457	53.3	1354	19.5	495	23.0	584	396	246	287.0	1855	66.7	252.3	31	25			
	SHRL XT D/L	L-4		E	14.00-1.5	17.5	445	55.1	1400	20.0	508	24.1	612	395	245	250.0	1613						
	SM-3A	L-3S		E A	14.00-1.5	18.8	477	54.8	1393			24.4	619	383	238	188.0	1212	80.0	302.0	38	30		
	SMO D/L-4B	L-4S			14.00-1.5	17.5	445	55.1	1400	20.0	508	24.1	612	395	245	250.0	1613						
	SMO D/L-5A	L-5S		E	14.00-1.5	17.5	445	55.1	1400	20.0	508	24.1	612	395	245	250.0	1613			82	65		
	SMO D/L-5B	L-5S		N A	14.00-1.5	17.5	445	55.1	1400	20.0	508	25.4	644	376	234	170.0	1097			104	59		
	SMO D/L-5C	L-5S		L	14.00-1.5	17.5	445	55.1	1400	20.0	508	24.1	612	395	245	250.0	1613			87	69		

Sizes in bold type can be obtained in locations in bold. Extended lead time may be needed in other locations.

Legend	N = North America L = Latin America	E = Europe / Africa / Mid East A = Asia / Australia	# = Estimated Data * = Tube Type Tire	^ = Work Capability Factor
---------------	--	--	--	----------------------------

LOAD LIMITS AT COLD INFLATION PRESSURES

5 MPH (10 KM/H) MAXIMUM SPEED OFF-THE-ROAD SLOW SPEED SERVICE

	PSI	33	36	40	44	47	51	54	58	62	65	69	73	76	80	83
BIAS	KPA	225	250	275	300	325	350	375	400	425	450	475	500	525	550	575
17.5-25	LBS	10500	11000	11700	12300	12800	13600(12)	13900	14800(14)	15200	15700	16100(16)	16500	17100	17600	18200(20)
	KG	4750	5000	5300	5600	5800	6150(12)	6300	6700(14)	6900	7100	7300(16)	7500	7750	8000	8250(20)

25 MPH (40 KM/H) MAXIMUM SPEED OFF-THE-ROAD TRACTOR AND GRADER SERVICE

	PSI	22	25	29	33	36	40	44	47
BIAS	KPA	150	175	200	225	250	275	300	325
17.5-25	LBS	5200	5680	6400(12)	6600(14)	6950	7400(16)	7850	8050(20)
	KG	2360	2575	2900(12)	3000(14)	3150	3350(16)	3550	3650(20)

30 MPH (50 KM/H) MAXIMUM SPEED OFF-THE-ROAD HAULAGE SERVICE

	PSI	25	29	33	36	40	44	47	51	54	58
BIAS	KPA	175	200	225	250	275	300	325	350	375	400
17.5-25	LBS	6800	7400	8050(12)	8550	8800	9350(16)	9900	10200	10700	11000(20)
	KG	3075	3350	3650(12)	3875	4000	4250(16)	4500	4625	4875	5000(20)

Legend

▲ Permafoam inflation or special rim required

WIDE BASE SIZE

WIDE BASE SIZE

RADIAL

DIMENSIONAL DATA



Size	Type	Ind Code	Current In Line Location	Rim Width & Flange	INFLATED DIMENSIONS				LOADED DIMENSIONS				Gross Contact Area		Tire Volume		Tread Depth		PERFORMANCE CAPABILITY								
					Overall Width		Overall Diameter		Load Sect & Growth		Static Load Rad								Revol Per	in2	cm2	gal	ltrs	in	mm	2S	
					in	mm	in	mm	in	mm	in	mm	mi	km					in	mm	tmph	tkph	tmph	tkph	tmph	tkph	
17.5R25	AS-3A	G-3	N	14.00-1.5	17.7	450	53.1	1348	20.1	510	23.8	604	396	246	185.0	1190	75.0	284.0	32	25							
	AT-2A	E-3		14.00-1.5	17.4	442	52.8	1341	19.1	485	24.1	612	398	247	190.0	1226	85.8	329.6	30	24	130	190					
	AT-2A	G-3		14.00-1.5	17.4	442	52.8	1341	19.1	485	24.1	612	398	247	245.0	1580	85.8	324.6	30	24							
	GP-2B	E-3	N	14.00-1.5	17.5	445	53.0	1346	19.4	493	24.2	615	396	246	205.0	1325	87.6	331.6	32	25	135	200	105	150	95	140	
	GP-2B	G-3	N	14.00-1.5	17.5	445	53.0	1346	19.4	493	24.2	615	396	246	205.0	1325	87.6	331.6	32	25	135	200	105	150	95	140	
	RL-2+	E-3+T		14.00-1.5	17.6	446	54.3	1379	19.7	500	24.4	621	387	240	205.0	1325	79.2	299.9	45	36	100	150	75	110			
	RL-2+	G-3+T		14.00-1.5	17.6	446	54.3	1379	19.7	500	24.4	621	387	240	205.0	1325	79.2	299.9	45	36	100	150	75	110			
	RL-2F	E-2		14.00-1.5	17.7	449	53.1	1349	19.7	500	24.2	614	396	246	174.0	1125	81.9	310.1	30	24	125	180	95	140			
	RL-2F	G-2		14.00-1.5	17.7	450	53.1	1349	19.8	502	24.4	620	396	246	190.0	1225	81.9	310.1	30	24							
	RL-3J	E-3	A	14.00-1.5	18.2	462	53.1	1349	20.2	513	24.2	615	396	246	210.0	1355	83.2	315.0	32	25	85	120					
	RL-3J	G-3	A	14.00-1.5	18.2	462	53.1	1349	20.2	513	24.2	615	396	246	210.0	1355	83.2	315.0	32	25							
	RT-3B	G-3		E	14.00-1.5	18.1	460	53.2	1351			23.7	603	396	246	235.0	1514			36	29					^76	^110
	SG-2B	G-2		N	14.00-1.5	18.0	457	53.1	1348			24.2	615	396	246					32	25						
	TL-3A+ #	E-3+T		E	14.00-1.5	18.2	462	53.2	1351			24.1	612	395	245			81.0	307.0	45	36	100#	150#	75#	110#	55#	75#

Loader tires for this size are located on page 77

Sizes in bold type can be obtained in locations in bold. Extended lead time may be needed in other locations.

Legend	N = North America	E = Europe / Africa / Mid East	# = Estimated Data	^ = Work Capability Factor
	L = Latin America	A = Asia / Australia	* = Tube Type Tire	

LOAD LIMITS AT COLD INFLATION PRESSURES

25 MPH (40 KM/H) MAXIMUM SPEED OFF-THE-ROAD TRACTOR AND GRADER SERVICE

	PSI	25	29	33	36	40	44	47	51	54	58	62	65
RADIAL	KPA	175	200	225	250	275	300	325	350	375	400	425	450
17.5R25	LBS	5200	5680	6400	6800	7400	8050*	8250	8800	9100	9650	10200	10500**
	KG	2360	2575	2900	3075	3350	3650*	3750	4000	4125	4375	4625	4750**

30 MPH (50 KM/H) MAXIMUM SPEED OFF-THE-ROAD HAULAGE SERVICE

	PSI	40	44	47	51	54	58	62	65	69	73	76
RADIAL	KPA	275	300	325	350	375	400	425	450	475	500	525
17.5R25	LBS	7400	7850	8250	8800	9100*	9650	10200	10500	11000	11400	12000**
	KG	3350	3550	3750	4000	4125*	4375	4625	4750	5000	5150	5450**

30 MPH (50 KM/H) MAXIMUM SPEED OFF-THE-ROAD ARTICULATED DUMP SERVICE

	PSI	29	33	36	40	44	47	51	54	58	62	65
RADIAL	KPA	200	225	250	275	300	325	350	375	400	425	450
17.5R25	LBS	6800	7400	8050	8550	9100*	9650	10200	10700	11400	12000**	12300
	KG	3075	3350	3650	3875	4125*	4375	4625	4875	5150	5450**	5600

30 MPH (50 KM/H) (50kph) MAXIMUM SPEED OFF-THE-ROAD HAULAGE SERVICE

30 MPH (50 KM/H) 50KPH MAXIMUM SPEED OFF-THE-ROAD SERVICE

Legend

▲ Permafoam inflation or special rim required

WIDE BASE SIZE

WIDE BASE SIZE

RADIAL

DIMENSIONAL DATA



Size	Type	Ind Code	Current In Line Location	Rim Width & Flange	INFLATED DIMENSIONS		LOADED DIMENSIONS				Revol Per mi km	Gross Contact Area		Tire Volume		Tread Depth		PERFORMANCE CAPABILITY										
					Overall Width in mm	Overall Diameter in mm	Load Sect in mm	Growth in mm	Static Load Rad in mm	in ²		cm ²	gal	ltrs	1/32 in	mm	2S		4S		6S							
17.5R25	AS-3A	L-3	N	14.00-1.5	17.7	450	53.3	1354	20.3	516	23.9	606	394	245	249.0	1606	75.0	284.0	32	25								
	AT-2A	L-3		14.00-1.5	17.4	442	52.8	1341	20.0	508	23.2	589	398	247	245.0	1580	85.8	324.6	30	24								
	GP-2B	L-3	N	A	14.00-1.5	17.5	445	53.0	1346	20.0	508	23.6	599	396	246	230.0	1487	87.6	331.1	32	25			75	110	65	100	
	RL-2+	L-3+T		14.00-1.5	17.6	446	54.3	1379	20.1	510	24.1	612	387	240	237.0	1532	79.2	295.9	45	36					55	80	50	70
	RL-2F	L-2		14.00-1.5	17.7	449	53.3	1354	20.1	510	23.8	604	394	244	245.0	1586	81.9	310.1	30	24					65	100	65	100
	RL-3A+	L-3+T		14.00-1.5																								
	RL-3J	L-3	N	A	14.00-1.5	18.2	462	53.1	1349	20.5	521	23.7	602	396	246	240.0	1548	83.2	315.0	32	25							
	RL-4K #	L-4		E	14.00-1.5	17.8	542	55.1	1400	19.6	499	24.6	624	381	237	215.0	1389	75.0	284.0	58	46							
	RL-4S	L-4S	L		14.00x1.5	18.1	460	55.2	1401	19.7	500	24.6	625	380.9	236.6	195.6	1262	87.0	329.0	59	46.4							
	Hi-Stability #																											
	RL-5K (08/08)	L-5	N		14.00-1.5	17.8	452	55.1	1400	20.2	513	24.6	624	381	237	215.0	1389	75.0	284.0	80	64							
	RL-5K (12/12)	L-5	N		14.00-1.5	17.8	452	55.1	1400	20.2	513	24.6	624	381	237	215.0	1389	75.0	284.0	80	64							
RT-3B	L-3		E	14.00-1.5	18.1	460	53.2	1351			23.7	603	396	246	235.0	1514			36	29							^76	^110
TL-3A+ #	L-3+T		E	14.00-1.5	18.2	462	53.2	1351	19.4	493	23.8	605	395	245	250.0	1613	81.0	307.0	45	36			^55#	^80#	^50#	^70#	^77	

Sizes in bold type can be obtained in locations in bold. Extended lead time may be needed in other locations.

Legend	N = North America	E = Europe / Africa / Mid East	# = Estimated Data	^ = Work Capability Factor
	L = Latin America	A = Asia / Australia	* = Tube Type Tire	

LOAD LIMITS AT COLD INFLATION PRESSURES

5 MPH (10 KM/H) MAXIMUM SPEED OFF-THE-ROAD SLOW SPEED SERVICE

RADIAL	PSI	29	33	36	40	44	47	51	54	58	62	65	69	73	76	80	
	KPA	200	225	250	275	300	325	350	375	400	425	450	475	500	525	550	Continued
17.5R25	LBS	8050	8800	9350	10200	10700	11700	12300	12800	13200	13600	14300	14800	15700*	16100	16500	
	KG	3650	4000	4250	4625	4850	5300	5600	5800	6000	6150	6500	6700	7100*	7300	7500	
	PSI	83	87	91	94	116											
	KPA	575	600	625	650	800											
	LBS	17100	17600	18200	18700**	22000***											
	KG	7750	8000	8250	8500**	10000***											

5 MPH (10 KM/H) OFF-THE-ROAD UNDERGROUND MINE SERVICE

RADIAL	PSI	29	33	36	40	44	47	51	54	58	62	65	69	73	76	80	
	KPA	200	225	250	275	300	325	350	375	400	425	450	475	500	525	550	Continued
17.5R25	LBS	8050	8800	9350	10200	10700	11700	12300	12800	13200	13600	14300	14800	15700*	16100	16500	
	KG	3650	4000	4250	4625	4850	5300	5600	5800	6000	6150	6500	6700	7100*	7300	7500	
	PSI	83	87	91	94	116											
	KPA	575	600	625	650	800											
	LBS	17100	17600	18200	18700**	22000***											
	KG	7750	8000	8250	8500**	10000***											

Legend

▲ Permafoam inflation or special rim required

WIDE BASE SIZE

WIDE BASE SIZE

DIMENSIONAL DATA

BIAS



Size	Type	Ind Code	Current In Line Location	Rim Width & Flange	INFLATED DIMENSIONS		LOADED DIMENSIONS		Revol Per mi	Gross Contact Area in ² cm ²	Tire Volume gal ltrs		Tread Depth 1/32 in mm		PERFORMANCE CAPABILITY									
					Overall Width in	Overall Diameter mm	Load Sect & Growth in	Static Load Rad in			mm	mm	mm	mm	2S	4S	6S	tkph	tkph	tkph	tkph			
20.5-25	GGL D/L-2A	E-2		17.00-2.0																				
	GGL D/L-2A	G-2		17.00-2.0																				
	GGL D/L-2A #	L-2		17.00-2.0	20.5	521	58.6	1488	21.7	551	26.5	673		36	28.6									
	GRL D/L-3A #	E-3		17.00-2.0	20.6	523	58.5	1486						36	29									
	GRL D/L-3A #	G-3		17.00-2.0	20.6	523	58.5	1486						36	29									
	GRL D/L-3A #	L-3		17.00-2.0	20.3	516	59.2	1504	21.5	546	26.8	681		36	29									
	HRL D/L-3A	G-3	L	17.00-2.0	21.8	554	59.2	1504	24.0	610	26.4	671	353	219	230.0	1485	116.8	442.1						
	HRL D/L-3A	L-3	L	17.00-2.0	22.3	565	59.4	1509	24.4	620	26.0	660	354	220	295.0	1903	116.8	442.1		45	70			
	HRL D/L-3C	L-3		17.00-2.0	22.8	579	58.1	1476	23.2	589	26.3	668	360	224										
	HRL DL 5A/C	L-5	L E A	17.00-2.0	21.8	554	61.3	1557	23.8	605	28.9	734	329	204	276.0	1781	99.3	376.0	93	74	^35	^50	^30	^40
	HRL E/L-3A	E-3	N L E A	17.00-2.0	21.8	554	58.9	1496	23.3	592	27.3	693	348	216	240.0	1548	116.8	442.1	38	30				
	HRL E/L-3A	G-3	N L A	17.00-2.0	21.8	554	59.2	1504	24.0	610	26.4	671	353	219	230.0	1485	116.8	442.1	38	30				
	HRL E/L-3A	L-3	N L E A	17.00-2.0	21.8	554	59.2	1504	23.9	607	26.8	681	354	220	297.0	1916	116.8	442.1	38	30			79	
	HRL-3A	E-3	L A	17.00-2.0	22.0	559	59.2	1504	24.1	612	26.3	668	353	219	240.0	1548	116.8	442.1	38	30	65	100		
	SGL D/L-2A	G-2	L	17.00-2.0	21.8	554	58.7	1491	24.0	610	26.2	665	356	221	235.0	1516	119.2	451.2	35	28				
	SGL D/L-2A	L-2	L	17.00-2.0	22.0	559	59.2	1504	23.1	586	25.1	639	368	229	285.0	1839	119.2	451.2	35	28				
	SGL E/L-2A	E-2	N E A	17.00-2.0	21.8	554	59.1	1501	24.0	610	25.1	639	355	221	277.0	1787	119.2	451.2	35	28				
	SGL E/L-2A	G-2	N A	17.00-2.0	21.8	554	58.7	1491	24.0	610	26.2	665	356	221	235.0	1516	119.2	451.2	35	28				
	SGL E/L-2A	L-2	N E A	17.00-2.0	21.8	554	59.1	1501	24.0	610	25.1	639	355	221	277.0	1787	119.2	451.2	35	28				
	SGL-2A	E-2	L A	17.00-2.0	21.4	544	59.1	1501	23.5	597	26.7	678	355	221	245.0	1581	119.2	451.2	35	28	75	110		
SHRL	L-3		17.00-2.0	21.8	554	59.2	1504	23.9	607	26.8	681	354	220	297.0	1916	116.8	442.1	38	30					
SXT LDR	L-5	N L E A	17.00-2.0	21.8	554	61.3	1557	23.8	605	28.9	734	329	204	276.0	1781	99.3	376.0	93	74	^35	^50	^30	^40	

Sizes in bold type can be obtained in locations in bold. Extended lead time may be needed in other locations.

Legend	N = North America L = Latin America	E = Europe / Africa / Mid East A = Asia / Australia	# = Estimated Data * = Tube Type Tire	^ = Work Capability Factor
---------------	--	--	--	----------------------------

LOAD LIMITS AT COLD INFLATION PRESSURES

5 MPH (10 KM/H) MAXIMUM SPEED OFF-THE-ROAD SLOW SPEED SERVICE

	PSI	33	36	40	44	47	51	54	58	62	65	69	73	76
BIAS	KPA	225	250	275	300	325	350	375	400	425	450	475	500	525
20.5-25	LBS	13900	14800(12)	15700	16500	17100	18200(16)	18700	19300	20400	20900(20)	21500	22000	22700(24)
	KG	6300	6700(12)	7100	7500	7750	8250(16)	8500	8750	9250	9500(20)	9750	10000	10300(24)

25 MPH (40 KM/H) MAXIMUM SPEED OFF-THE-ROAD TRACTOR AND GRADER SERVICE

	PSI	22	25	29	33	36	40
BIAS	KPA	150	175	200	225	250	275
20.5-25	LBS	6950	7850(12)	8250	8800(16)	9350	9900(20)
	KG	3150	3550(12)	3750	4000(16)	4250	4500(20)

30 MPH (50 KM/H) MAXIMUM SPEED OFF-THE-ROAD HAULAGE SERVICE

	PSI	25	29	33	36	40	44	47
BIAS	KPA	175	200	225	250	275	300	325
20.5-25	LBS	9100	9900(12)	10700	11400	12000(16)	12800	13200(20)
	KG	4125	4500(12)	4875	5150	5450(16)	5800	6000(20)

Legend

▲ Permafoam inflation or special rim required

WIDE BASE SIZE

WIDE BASE SIZE

RADIAL

DIMENSIONAL DATA



Size	Type	Ind Code	Current In Line Location	Rim Width & Flange	INFLATED DIMENSIONS		LOADED DIMENSIONS		Revol Per	Gross Contact Area		Tire Volume		Tread Depth		PERFORMANCE CAPABILITY										
					Overall Width	Overall Diameter	Load Sect & Growth	Static Load Rad		in ²	cm ²	gal	ltrs	1/32	mm	2S		4S		6S						
					in	mm	in	mm	in	mm	mi	km			in	mm	tmph	tkph	tmph	tkph	tmph	tkph				
20.5R25	AS-3A	G-3	N L E A	17.00-2.0	20.3	516	25.0	635	23.5	597	26.7	678	362.8	225.4	323.0	2084	128.0	485.0	50	31.8						
	GP-2B	E-3	N A	17.00-2.0	20.9	532	58.1	1476	23.4	594	26.4	671	362	225	277.0	1787	132.4	501.3	36	29	150	220	115	170	105	150
	GP-2B	G-3	N A	17.00-2.0	20.9	532	58.1	1476	23.4	594	26.4	671	362	225	277.0	1787	132.4	501.3	36	29	150	220	115	170	105	150
	GP-4B AT	E-4	A	17.00-2.0	21.0	533	58.9	1496	23.3	592	26.0	660	357	222	296.0	1910			62	49						
	GP-4D	E-4	N E	17.00-2.0	21.1	536	58.9	1495	23.4	593	26.6	677	357	222	295.0	1904	125.0	473.0	66	52	115	170	90	130	80	115
	GP-4D	G-4	N E	17.00-2.0	21.1	536	58.9	1495			27.0	687	357	222	274.0	1767	125.0	473.0	66	52						
	RL-2+	E-3+T	N E A	17.00-2.0	21.0	533	58.4	1483	23.1	587	27.0	686	360	224	236.0	1520	124.4	470.9	50	40	120	180	90	130		
	RL-2+	G-3+T	N E	17.00-2.0	21.3	541	58.0	1473	23.5	597	26.8	681	362	225	218.0	1406	124.4	470.9	50	40						
	RL-2F	E-2		17.00-2.0	21.2	537	58.5	1486	23.5	597	26.8	681	359	223	284.0	1832	124.4	470.9	34	27	145	210	105	150		
	RL-2F	G-2		17.00-2.0	21.2	537	58.5	1486	23.4	594	27.0	686	359	223	250.0	1612	124.4	470.9	34	27						
	RL-3J	G-3	A	17.00-2.0	21.3	541	58.6	1488	23.6	599	26.7	678	359	223	288.0	1858	129.8	491.4	36	29						
	RT-3B	E-3		17.00-2.0	21.4	544	58.5	1486	23.7	602	26.6	676	360	224	280.0	1806	125.0	473.0	41	32						
	RT-3B	G-3	N E	17.00-2.0	21.4	544	58.5	1486	23.8	605	26.5	673	360	224	294.0	1897	125.0	473.0	41	32						
	TL-3A+	E-3+T	E	17.00-2.0	21.5	545	58.1	1476	23.7	602	25.8	655	361	225	337.0	2172	133.0	503.0	50	40	120	180	90	130	70	100

Loader tires for this size are located on page 83

Sizes in bold type can be obtained in locations in bold. Extended lead time may be needed in other locations.

Legend	N = North America	E = Europe / Africa / Mid East	# = Estimated Data	^ = Work Capability Factor
	L = Latin America	A = Asia / Australia	* = Tube Type Tire	

LOAD LIMITS AT COLD INFLATION PRESSURES

25 MPH (40 KM/H) MAXIMUM SPEED OFF-THE-ROAD TRACTOR AND GRADER SERVICE

	PSI	25	29	33	36	40	44	47	51	54	58	62	65
RADIAL	KPA	175	200	225	250	275	300	325	350	375	400	425	450
20.5R25	LBS	6950	7600	8550	9100	9650	10200*	10700	11400	12000	12800	13200	13600**
	KG	3150	3450	3825	4125	4375	4625*	4875	5150	5450	5800	6000	6150**

30 MPH (50 KM/H) MAXIMUM SPEED OFF-THE-ROAD HAULAGE SERVICE

	PSI	40	44	47	51	54	58	62	65	69	73	76
RADIAL	KPA	275	300	325	350	375	400	425	450	475	500	525
20.5R25	LBS	9650	10500	11000	11700	12300*	12800	13600	14300	14800	15200	16100**
	KG	4375	4750	5000	5300	5600*	5800	6150	6500	6700	6900	7300**

30 MPH (50 KM/H) MAXIMUM SPEED OFF-THE-ROAD ARTICULATED DUMP SERVICE

	PSI	29	33	36	40	44	47	51	54	58	62	65
RADIAL	KPA	200	225	250	275	300	325	350	375	400	425	450
20.5R25	LBS	8800	9650	10500	11000	12000	12800*	13200	13900	14800	15200	16100**
	KG	4000	4375	4750	5000	5450	5800*	6000	6300	6700	6900	7300**

30 MPH (50 KM/H) (50kph) MAXIMUM SPEED OFF-THE-ROAD HAULAGE SERVICE

30 MPH (50 KM/H) 50KPH MAXIMUM SPEED OFF-THE-ROAD SERVICE

Legend

▲ Permafoam inflation or special rim required

WIDE BASE SIZE

WIDE BASE SIZE

RADIAL

DIMENSIONAL DATA



Size	Type	Ind Code	Current In Line Location	Rim Width & Flange	INFLATED DIMENSIONS				LOADED DIMENSIONS				Gross Contact Area		Tire Volume		Tread Depth		PERFORMANCE CAPABILITY										
					Overall Width		Overall Diameter		Load Sect & Growth		Static Load Rad		mi	km	in ²	cm ²	gal	ltrs	1/32	mm	2S		4S		6S				
					in	mm	in	mm	in	mm	in	mm							in	mm	tmph	tkph	tmph	tkph	tmph	tkph			
20.5R25	AS-3A	L-3	N L E A	17.00-2.0	20.3	516	25.0	635	23.5	597	26.7	678	362.8	225.4	323.0	2084	128.0	485.0	50	31.8									
	GP-2B	L-3	N	17.00-2.0	20.9	532	58.1	1476	24.0	610	25.7	653	362	225	328.0	2116	132.4	501.3	36	29			^100	^150	^90	^130			
	GP-4B AT	L-4		A	17.00-2.0	21.0	533	58.9	1496	23.7	602	26.2	665	356	221	312.0	2012	62	49										
	GP-4D	L-4		E	17.00-2.0	21.1	536	58.9	1495	26.2	665	25.6	651	357	222	338.0	2184	125.0	473.0	66	52								
	RL-2+	L-3+T	N	E	17.00-2.0	21.1	536	58.4	1483	23.7	601	25.9	658	360	224	286.0	1847	124.4	470.9	50	40			^65	^100	^60	^90		
	RL-2F	L-2			17.00-2.0	21.2	537	58.5	1486	23.9	607	26.1	662	359	223	324.0	2090	124.4	470.9	34	27			75	110	70	100		
	RL-3J	L-3			A	17.00-2.0	21.3	541	58.6	1488	24.0	610	26.1	663	359	223	325.0	2097	129.8	491.4	36	29							
	RL-3S #	L-3S		E	17.00-2.0	21.8	554	60.4	1534	24.3	617	26.7	679	348	216	277.0	1786	150.0	568.0	43	34								
	RL-4K (24/24) #	L-4		E	17.00-2.0	21.8	554	60.4	1534	24.3	617	26.7	679	348	216	277.0	1786	125.0	473.0	64	51								
	RL-5K (24/24)	L-5	N	E A	17.00-2.0	21.8	554	60.4	1534	24.2	615	27.3	693	348	216	285.0	1839	129.5	490.1	90	71					^55	^80		
	RL-5S	L-5S		E	17.00-2.0																								
	RT-3B	L-3	N	E	17.00-2.0	21.4	544	58.5	1486	24.5	622	26.0	660	360	224	358.0	2310	125.0	473.0	41	32								
	RT-5C	L-5			17.00-2.0	22.7	577	63.8	1621	25.2	640	27.6	701	331	206														
	RT-5D Hi-Stability	L-5	N	L E A	17.00-2.0	21.8	554	60.4	1534	24.3	617	26.7	679	347.8	216.1	276.8	1786	125.0	473.0	95	74.9								83
	SM-3A	L-3S			17.00-2.0	21.4	544	58.9	1495	23.8	605	26.3	668	357	222	330.0	2129	129.5	490.1	90	71					^65	^100	^60	^90
TL-3A+	L-3+T		E	17.00-2.0	21.5	545	58.1	1476	23.7	602	25.8	655	361	225	337.0	2172	133.0	503.0	50	40									

Sizes in bold type can be obtained in locations in bold. Extended lead time may be needed in other locations.

Legend	N = North America L = Latin America	E = Europe / Africa / Mid East A = Asia / Australia	# = Estimated Data * = Tube Type Tire	^ = Work Capability Factor
---------------	--	--	--	----------------------------

LOAD LIMITS AT COLD INFLATION PRESSURES

5 MPH (10 KM/H) MAXIMUM SPEED OFF-THE-ROAD SLOW SPEED SERVICE

RADIAL	PSI	29	33	36	40	44	47	51	54	58	62	65	69	73	76	80	Continued
	KPA	200	225	250	275	300	325	350	375	400	425	450	475	500	525	550	
20.5R25	LBS	10500	11400	12300	13200	13900	14800	15700	16500	17600	18200	19300	19800	20900*	21500	22000	
	KG	4750	5150	5600	6000	6300	6700	7100	7500	8000	8250	8750	9000	9500*	9750	10000	
	PSI	83	87	91	94												
	KPA	575	600	625	650												
	LBS	22700	24000	24700	25400**												
	KG	10300	10900	11200	11500**												

5 MPH (10 KM/H) OFF-THE-ROAD UNDERGROUND MINE SERVICE

RADIAL	PSI	29	33	36	40	44	47	51	54	58	62	65	69	73	76	80	Continued
	KPA	200	225	250	275	300	325	350	375	400	425	450	475	500	525	550	
20.5R25	LBS	10500	11400	12300	13200	13900	14800	15700	16500	17600	18200	19300	19800	20900*	21500	22000	
	KG	4750	5150	5600	6000	6300	6700	7100	7500	8000	8250	8750	9000	9500*	9750	10000	
	PSI	83	87	91	94												
	KPA	575	600	625	650												
	LBS	22700	24000	24700	25400**												
	KG	10300	10900	11200	11500**												

Legend

▲ Permafoam inflation or special rim required

WIDE BASE SIZE

WIDE BASE SIZE

BIAS

DIMENSIONAL DATA



Size	Type	Ind Code	Current In Line Location		Rim Width & Flange	INFLATED DIMENSIONS				LOADED DIMENSIONS				Revol Per		Gross Contact Area		Tire Volume		Tread Depth		PERFORMANCE CAPABILITY						
						Overall Width		Overall Diameter		Load Sect & Growth		Static Load Rad										2S		4S		6S		
						in	mm	in	mm	in	mm	in	mm	mi	km	in ²	cm ²	gal	ltrs	in	mm	mph	tkph	mph	tkph	mph	tkph	
23.5-25	ELV-3A	IND-3	N	A	19.50-2.5	24.9	633	64.6	1640	27.2	690	29.0	737	300	186	422.0	2723	144.7	547.6	41	33							
	GGL D/L-2A	E-2			19.50-2.5																							
	GGL D/L-2A	G-2			19.50-2.5																							
	GGL D/L-2A #	L-2			19.50-2.5	24.2	615	63.5	1613	25.6	650	28.5	724							40	31.8							
	GRL D/L-3A	E-3			19.50-2.5	23.6	599	63.0	1600	25.0	635	28.3	719							40	31.8							
	GRL D/L-3A	G-3			19.50-2.5																							
	GRL D/L-3A	L-3			19.50-2.5	23.6	599	63.0	1600	25.0	635	28.3	719							40	31.8							
	HRL D/L-3A	G-3			19.50-2.5	24.2	615	63.6	1615	26.7	678	28.3	719	329	204	310.0	2000	144.7	547.2	41	33							
	HRL D/L-3A	L-3		A	19.50-2.5	25.0	635	64.0	1626	26.8	681	28.2	716	328	204	418.0	2696	144.7	547.2	41	33			50	70			
	HRL D/L-3B	L-3			19.50-2.5	24.6	626	63.4	1610	26.3	668	27.9	710	336	209	431.0	2781	142.8	540.5	40	33							
	HRL D/L-3C	L-3			19.50-2.5	22.8	579	62.9	1597	25.6	650	27.7	703	340	211	414.0	2671			34	28							
	HRL D/L-5C	L-5			19.50-2.5	24.4	619	66.0	1676	26.4	671	29.2	740	317	197	342.0	2207			100	79							
	HRL E/L-3A	E-3	N	L	A	19.50-2.5	24.5	622	63.8	1620	26.6	676	28.7	729	328	204	352.0	2271	144.7	547.6	41	33						
	HRL E/L-3A	G-3	N		A	19.50-2.5	24.2	615	63.6	1615	26.7	678	28.3	719	329	204	310.0	2000	144.7	547.6	41	33						
	HRL E/L-3A	L-3	N	L	A	19.50-2.5	24.2	615	63.6	1615	27.2	691	28.0	711	336	209	414.0	2671	144.7	547.6	41	33						
	HRL E/L-3B	E-3			19.50-2.5	24.6	626	63.4	1610	26.3	668	27.9	710	336	209	431.0	2781	142.8	540.5	40	33							
	HRL-3A	E-3	N		A	19.50-2.5	24.5	622	63.8	1620	26.6	676	28.7	729	328	204	352.0	2271	144.7	547.2	41	33			70	100		
	SGL D/L-2A	G-2			A	19.50-2.5	24.4	620	63.0	1600	26.8	681	28.0	711	332	206	275.0	1774	145.3	550.1	39	31						
	SGL D/L-2A	L-2			A	19.50-2.5	24.7	627	62.9	1598	26.6	676	26.8	681	337	210	496.0	3202	145.3	550.1	39	31			65	100		
	SGL E/L-2A	E-2	N	L	E	A	19.50-2.5	24.4	620	64.1	1628	27.4	696	27.8	706	335	208	375.0	2420	145.3	550.1	39	31					
SGL E/L-2A	G-2	N			19.50-2.5	24.4	620	63.0	1600	26.8	681	28.0	711	332	206	275.0	1774	145.3	550.1	39	31							
SGL E/L-2A	L-2	N	L	E	A	19.50-2.5	24.4	620	64.1	1628	27.7	704	27.1	688	336	209	470.0	3032	145.3	550.1	39	31			^65	^100		
SGL-2A	E-2	N		A	19.50-2.5	24.4	620	64.1	1628	27.4	696	27.1	688	347	216	375.0	2420	145.3	550.1	39	31			90	130			
SHRL XT D/L	L-4	N			19.50-2.5	24.6	625	66.2	1681	27.1	688	30.5	775	309	192	326.0	2103	146.7	555.1	70	56			^45	^70			
SXT DL	L-5	N	L	E	A	19.50-2.5	24.3	617	66.4	1687	26.4	671	31.0	787	304	189	348.0	2245	136.8	517.0	100	79			^40	^60		

85

Sizes in bold type can be obtained in locations in bold. Extended lead time may be needed in other locations.

Legend	N = North America	E = Europe / Africa / Mid East	# = Estimated Data	^ = Work Capability Factor
	L = Latin America	A = Asia / Australia	* = Tube Type Tire	

LOAD LIMITS AT COLD INFLATION PRESSURES

5 MPH (10 KM/H) MAXIMUM SPEED OFF-THE-ROAD SLOW SPEED SERVICE

	PSI	33	36	40	44	47	51	54	58	62	65	69	73	76	80	83	
BIAS	KPA	225	250	275	300	325	350	375	400	425	450	475	500	525	550	575	Continued
23.5-25	LBS	17600(12)	18700	19800	20900(16)	22000	23400	24000(20)	24700	26000	26800	27600(24)	28300	29100	30000(28)	30900	
	KG	8000(12)	8500	9000	9500(16)	10000	10600	10900(20)	11200	11800	12150	12500(24)	12850	13200	13600(28)	14000	
	PSI	87	91	94	98	102	105	109	112								
	KPA	600	625	650	675	700	725	750	775								
	LBS	32000	32000(32)	33100	34200	34200(36)	35300	36400	36400(40)								
	KG	14500	14500(32)	15000	15500	15500(36)	16000	16500	16500(40)								

25 MPH (40 KM/H) MAXIMUM SPEED OFF-THE-ROAD TRACTOR AND GRADER SERVICE

	PSI	22	25	29	33	36
BIAS	KPA	150	175	200	225	250
23.5-25	LBS	8800(12)	9650	10500(16)	11400	12000(20)
	KG	4000(12)	4375	4750(16)	5150	5450(20)

30 MPH (50 KM/H) MAXIMUM SPEED OFF-THE-ROAD HAULAGE SERVICE

	PSI	25	29	33	36	40	44	47	51
BIAS	KPA	175	200	225	250	275	300	325	350
23.5-25	LBS	11700(12)	12800	13600(16)	14300	15200	16100(20)	17100	17600(24)
	KG	5300(12)	5800	6150(16)	6500	6900	7300(20)	7750	8000(24)

Legend

▲ Permafoam inflation or special rim required

WIDE BASE SIZE

LOAD LIMITS AT COLD INFLATION PRESSURES

25 MPH (40 KM/H) MAXIMUM SPEED OFF-THE-ROAD TRACTOR AND GRADER SERVICE

	PSI	25	29	33	36	40	44	47	51	54	58	62	65
RADIAL	KPA	175	200	225	250	275	300	325	350	375	400	425	450
23.5R25	LBS	8800	9900	10700	11700	12300	13200*	13900	14300	15200	16100	16500	17100**
	KG	4000	4500	4875	5300	5600	6000*	6300	6500	6900	7300	7500	7750**

30 MPH (50 KM/H) MAXIMUM SPEED OFF-THE-ROAD HAULAGE SERVICE

	PSI	40	44	47	51	54	58	62	65	69	73	76
RADIAL	KPA	275	300	325	350	375	400	425	450	475	500	525
23.5R25	LBS	12300	13200	14300	14800	15700*	16500	17100	18200	18700	19800	20400**
	KG	5600	6000	6500	6700	7100*	7500	7750	8250	8500	9000	9250**

30 MPH (50 KM/H) MAXIMUM SPEED OFF-THE-ROAD ARTICULATED DUMP SERVICE

	PSI	29	33	36	40	44	47	51	54	58	62	65
RADIAL	KPA	200	225	250	275	300	325	350	375	400	425	450
23.5R25	LBS	11000	12000	13200	13900	14800	16100*	16500	17600	18700	19300	20400**
	KG	5000	5450	6000	6300	6700	7300*	7500	8000	8500	8750	9250**

30 MPH (50 KM/H) (50kph) MAXIMUM SPEED OFF-THE-ROAD HAULAGE SERVICE

30 MPH (50 KM/H) 50KPH MAXIMUM SPEED OFF-THE-ROAD SERVICE

Legend

▲ Permafoam inflation or special rim required

WIDE BASE SIZE

WIDE BASE SIZE

RADIAL

DIMENSIONAL DATA



Size	Type	Ind Code	Current In Line Location	Rim Width & Flange	INFLATED DIMENSIONS				LOADED DIMENSIONS				Revol Per mi km	Gross Contact Area		Tire Volume		Tread Depth		PERFORMANCE CAPABILITY					
					Overall Width		Overall Diameter		Load Sect & Growth		Static Load Rad			in ²	cm ²	gal	ltrs	1/32 in	mm	2S		4S		6S	
					in	mm	in	mm	in	mm	in	mm		in	cm	in	mm	in	mm	mph	tkph	mph	tkph	mph	tkph
23.5R25	GP-2B	L-3	N	19.5-2.5	24.1	612	63.3	1608	27.8	706	28.2	718	336	209	337.0	2174	192.6	728.9	40	32	^115	^170	^95	^140	
	GP-3D	L-3T		19.5-2.5	24.1	612	63.3	1608	27.8	706	28.2	718	332	206	337.0	2174	192.6	728.9	47	37	115	170	95	140	
	GP-4B AT	L-4	A	19.5-2.5	24.6	626	63.8	1620					329	204			177.8	673.0	68	54					
	GP-4C	L-4		19.5-2.5	24.8	629	65.5	1665	27.9	708	29.3	745	321	199	400.0	2582	181.5	686.9	68	54	70	100	65	100	
	GP-4D	L-4	E	19.50-2.5	24.9	632	63.7	1618	28.5	723	28.0	710	328	204	397.0	2560	175.0	662.0	69	55					
	RL-2+	L-3+T	N	19.5-2.5	24.1	612	63.9	1623	27.5	699	28.2	716	329	204	394.0	2542	176.9	669.5	53	42	^70	^100	^65	^100	
	RL-2F	L-2		19.5-2.5	24.1	613	63.5	1613	27.2	691	28.1	714	331	206	382.0	2465	177.7	672.7	38	30	85	120	80	120	
	RL-3J	L-3	A	19.5-2.5	24.5	622	63.6	1615	27.8	706	27.7	704	330	205	410.0	2645	181.1	685.4	40	32					
	RL-3S Hi-Stability #	L-3S	L	19.5x2.5	24.5	622	65.1	1654	27.4	697	28.7	729	322.7	200.5	379.0	2445	189.0	715.0	50	39					
	RL-4K (24/24)	L-4	E	19.5-2.5	24.5	622	65.1	1653	27.4	697	28.7	729	232	201	379.0	2445	175.0	662.0	68	54					
	RL-4S Hi-Stability	L-4S		19.5x2.5																					
	RL-5K (24/24)	L-5	N	E A	19.5-2.5	24.5	623	65.1	1654	27.3	694	29.4	747	333	207	379.0	2445	160.6	607.9	99	79	^55	^80	^5	89
	RL-5S	L-5S		E	19.5-2.5	24.5	623	65.1	1654	27.3	694	29.4	747	333	207	379.0	2445	160.6	607.9	99	79				
	RT-3B #	L-3	N	E	19.5-2.5	25.2	640	63.2	1605	28.2	718	27.9	710	332	206	450.0	2903	175.0	662.0	44	35			^80#	^120#
	RT-5C	L-5		E	19.5-2.5	24.0	610	65.7	1669	27.1	688	29.3	745	321	199	383.0	2473			98	78				
RT-5D Hi-Stability	L-5	N	L E A	19.50-2.5	24.5	622	65.1	1654	27.4	697	28.7	729	322.7	200.5	379.0	2445	175.0	662.0	101	80					
SM-3A	L-3S			19.5-2.5	24.0	610	64.1	1628	27.2	691	28.4	722	328	204	360.0	2323	178.0	673.7							
TL-3A+	L-3+T		E	19.5-2.5	24.2	615	63.9	1623	27.2	691	28.6	726	329	204	353.0	2277	175.0	662.0	54	43					

Sizes in bold type can be obtained in locations in bold. Extended lead time may be needed in other locations.

Legend	N = North America	E = Europe / Africa / Mid East	# = Estimated Data	^ = Work Capability Factor
	L = Latin America	A = Asia / Australia	* = Tube Type Tire	

LOAD LIMITS AT COLD INFLATION PRESSURES

5 MPH (10 KM/H) MAXIMUM SPEED OFF-THE-ROAD SLOW SPEED SERVICE

RADIAL	PSI	29	33	36	40	44	47	51	54	58	62	65	69	73	76	80	Continued
	KPA	200	225	250	275	300	325	350	375	400	425	450	475	500	525	550	
23.5R25	LBS	13200	14300	15700	17100	18200	19300	20400	21500	22700	23400	24700	25400	26800*	27600	28300	
	KG	6000	6500	7100	7750	8250	8750	9250	9750	10300	10600	11200	11500	12150*	12500	12850	
	PSI	83	87	91	94												
	KPA	575	600	625	650												
	LBS	29100	30000	30900	32000**												
	KG	13200	13600	14000	14500**												

5 MPH (10 KM/H) OFF-THE-ROAD UNDERGROUND MINE SERVICE

RADIAL	PSI	29	33	36	40	44	47	51	54	58	62	65	69	73	76	80	Continued
	KPA	200	225	250	275	300	325	350	375	400	425	450	475	500	525	550	
23.5R25	LBS	13200	14300	15700	17100	18200	19300	20400	21500	22700	23400	24700	25400	26800*	27600	28300	
	KG	6000	6500	7100	7750	8250	8750	9250	9750	10300	10600	11200	11500	12150*	12500	12850	
	PSI	83	87	91	94												
	KPA	575	600	625	650												
	LBS	29100	30000	30900	32000**												
	KG	13200	13600	14000	14500**												

Legend

▲ Permafoam inflation or special rim required

WIDE BASE SIZE

WIDE BASE SIZE

DIMENSIONAL DATA

BIAS



Size	Type	Ind Code	Current In Line Location	Rim Width & Flange	INFLATED DIMENSIONS				LOADED DIMENSIONS				Gross Contact Area		Tire Volume		Tread Depth		PERFORMANCE CAPABILITY																					
					Overall Width		Overall Diameter		Load Sect & Growth		Static Load Rad								Revol Per	mi	km	in2	cm2	gal	ltrs	in	mm	2S		4S		6S								
					in	mm	in	mm	in	mm	in	mm	in	mm	mi	km	in2	cm2	gal	ltrs	1/32	mm	in	mm	in	mm	in	mm	in	mm	in	mm	in	mm	in	mm				
26.5-25	GRL D/L-3A #	L-3		22.00	28.2	716	68.4	1737	29.9	760	30.5	775																												
	HRL D/L-5C	L-5	N	22.00-3.0	27.4	696	71.4	1813	29.2	742	33.0	838	284	177	440.0	2838																								
	SGL D/L-2A	L-2	N	22.00-3.0	27.5	699	68.0	1727	29.7	754	28.5	724	313	195	599.0	3864	188.0	711.6										^75	^110											
	SGL-2A	E-2		22.00-3.0	27.5	691	68.9	1750	30.1	765	29.9	759	315	196	400.0	2581	188.0	712.0											105	150										
	SHRL	E-3	N L A	22.00-3.0	27.2	691	68.9	1750	30.1	765	29.9	759	315	196	400.0	2581	188.0	712.0											90	130										
	SHRL DL	L-3	N L A	22.00-3.0	27.6	701	68.4	1737	29.3	744	29.9	759	308	191	490.0	3162	223.2	844.9											^60	^90	^55	^80								
	SHRL XT D/L	L-4	N	22.00-3.0	27.7	704	70.6	1793	30.8	782	32.2	818	292	181	453.0	2923	178.7	676.3											^50	^70	^45	^70								
	SMO D/L-5B	L-5S		22.00-3.0	27.4	696	71.0	1803	29.9	759	33.0	838	286	178	409.0	2639	175.8	664.5																						
	SMO D/L-5C	L-5S	N A	22.00-3.0	27.4	696	71.0	1803	29.9	759	33.0	838	286	178	409.0	2639	175.8	664.5											^40	^60	^35	^50								
	SMO D/L-5D	L-5S		22.00-3.0	27.4	696	71.0	1803	29.9	759	33.0	838	286	178	302.0	1948																								
	SMO D/L-5E	L-5S	N A	22.00-3.0	25.2	640	70.4	1788	27.5	699	31.8	808	296	184	300.0	1935																								
	SXT DL	L-5	N L A	22.00-3.0	27.4	696	71.0	1803	29.9	760	33.0	838	286	178	409.0	2639	185.3	701.5											^45	^70										

Sizes in bold type can be obtained in locations in bold. Extended lead time may be needed in other locations.

Legend	N = North America L = Latin America	E = Europe / Africa / Mid East A = Asia / Australia	# = Estimated Data * = Tube Type Tire	^ = Work Capability Factor
---------------	--	--	--	----------------------------

LOAD LIMITS AT COLD INFLATION PRESSURES

5 MPH (10 KM/H) MAXIMUM SPEED OFF-THE-ROAD SLOW SPEED SERVICE

	PSI	33	36	40	44	47	51	54	58	62	65	69	73	76	80
BIAS	KPA	225	250	275	300	325	350	375	400	425	450	475	500	525	550
26.5-25	LBS	22000(14)	24000	25400	26800	27600	29100(20)	30000	30900(24)	32000	33100(26)	34200(28)	35300	36400	37500(32)
	KG	10000(14)	10900	11500	12150	12500	13200(20)	13600	14000(24)	14500	15000(26)	15500(28)	16000	16500	17000(32)

30 MPH (50 KM/H) MAXIMUM SPEED OFF-THE-ROAD HAULAGE SERVICE

	PSI	25	29	33	36	40	44	47	51
BIAS	KPA	175	200	225	250	275	300	325	350
26.5-25	LBS	14800	16100	17100	18200(20)	19300	20400(24)	20900(26)	22000(28)
	KG	6700	7300	7750	8250(20)	8750	9250(24)	9500(26)	10000(28)

Legend ▲ Permafoam inflation or special rim required

WIDE BASE SIZE

WIDE BASE SIZE

RADIAL

DIMENSIONAL DATA



Size	Type	Ind Code	Current In Line Location		Rim Width & Flange	INFLATED DIMENSIONS		LOADED DIMENSIONS		Revol Per		Gross Contact Area		Tire Volume		Tread Depth		PERFORMANCE CAPABILITY									
						Overall Width	Overall Diameter	Load Sect & Growth	Static Load Rad									2S		4S		6S					
						in	mm	in	mm	in	mm	in ²	cm ²	gal	ltrs	in	mm	tmph	tkph	tmph	tkph	tmph	tkph				
26.5R25	EV-3B	IND-3			22.0-3.0	26.8	681	68.4	1737	30.8	782	30.0	762	307	191	485.0	3128	239.0	904.5	45	36						
	GP-2B	E-3	N	A	22.0-3.0	26.8	681	68.4	1737	30.0	762	30.9	785	307	191	400.0	2581	239.0	904.5	45	36	195	280	155	230	130	190
	GP-4B AT #	E-4		A	22.0-3.0	26.7	678	69.0	1753	30.0	762	31.2	792	303	188	400.0	2581			67	53	145#	210#	110#	160#	90#	130#
	GP-4D #	E-4		E A	22.0-3.0	27.6	701	68.8	1748	29.9	759	31.2	792	303	188	429.0	2770	225.0	852.0	69	55	145#	210#	110#	160#	95#	140#
	RL-2+	E-3+T	N	A	22.0-3.0	27.3	693	68.8	1748	29.7	754	31.2	792	305	190	400.0	2581	237.6	899.4	56	44	155	230	115	170		
	RL-2F	E-2			22.0-3.0	27.5	699	68.8	1748	30.2	767	31.5	800	305	190	345.0	2226	240.4	909.9	43	34	180	260	135	200		
	RT-3B	E-3			22.0-3.0	27.4	695	68.6	1741	30.4	773	30.1	765	306	190	462.0	2981	250.0	946.0	50	40						
	TL-3A+	E-3+T	N	E	22.0-3.0	27.4	695	68.6	1741	30.4	773	30.1	765	306	190	462.0	2981	250.0	946.0	50	40						
			N	E	22.0-3.0	27.5	699	69.0	1753	30.2	767	30.3	770	305	189	484.0	3121	250.0	946.0	59	47	155	230	115	170	95	140

Loader tires for this size are located on page 95

Sizes in bold type can be obtained in locations in bold. Extended lead time may be needed in other locations.

Legend	N = North America L = Latin America	E = Europe / Africa / Mid East A = Asia / Australia	# = Estimated Data * = Tube Type Tire	^ = Work Capability Factor
---------------	--	--	--	----------------------------

LOAD LIMITS AT COLD INFLATION PRESSURES

25 MPH (40 KM/H) MAXIMUM SPEED OFF-THE-ROAD TRACTOR AND GRADER SERVICE

RADIAL	PSI	18	22	25	29	33	36	40	44
	KPA	125	150	175	200	225	250	275	300
26.5R25	LBS	8550	9900	11000	12300	13600	14800	15700	16500*
	KG	3875	4500	5000	5600	6150	6700	7100	7500*

30 MPH (50 KM/H) MAXIMUM SPEED OFF-THE-ROAD HAULAGE SERVICE

RADIAL	PSI	40	44	47	51	54	58	62	65	69	73	76
	KPA	275	300	325	350	375	400	425	450	475	500	525
26.5R25	LBS	15700	16500	17600	18700	19800*	20900	21500	22700	23400	24700	25400**
	KG	7100	7500	8000	8500	9000*	9500	9750	10300	10600	11200	11500**

30 MPH (50 KM/H) MAXIMUM SPEED OFF-THE-ROAD ARTICULATED DUMP SERVICE

RADIAL	PSI	29	33	36	40	44	47	51	54	58	62	65
	KPA	200	225	250	275	300	325	350	375	400	425	450
26.5R25	LBS	13900	15200	16500	17600	18700	19800*	20900	22000	23400	24000	25400**
	KG	6300	6900	7500	8000	8500	9000*	9500	10000	10600	10900	11500**

30 MPH (50 KM/H) (50kph) MAXIMUM SPEED OFF-THE-ROAD HAULAGE SERVICE

30 MPH (50 KM/H) 50KPH MAXIMUM SPEED OFF-THE-ROAD SERVICE

Legend

▲ Permafoam inflation or special rim required

WIDE BASE SIZE

WIDE BASE SIZE

RADIAL

DIMENSIONAL DATA



Size	Type	Ind Code	Current In Line Location	Rim Width & Flange	INFLATED DIMENSIONS				LOADED DIMENSIONS				Revol Per		Gross Contact Area		Tire Volume		Tread Depth		PERFORMANCE CAPABILITY						
					Overall Width		Overall Diameter		Load Sect & Growth		Static Load Rad										2S		4S		6S		
					in	mm	in	mm	in	mm	in	mm	mi	km	in ²	cm ²	gal	ltrs	in	mm	tmph	tkph	tmph	tkph	tmph	tkph	
26.5R25	GP-2B	L-3	N	22.0-3.0	26.8	681	68.4	1737	30.8	782	30.0	762	307	191	485.0	3128	239.0	904.5	45	36			^130	^190	^110	^160	
	GP-4B AT	L-4	A	22.0-3.0	26.7	678	69.0	1753					303	188					67	53							
	GP-4D	L-4	E A	22.0-3.0	27.6	701	68.8	1748	30.8	782	30.2	766	306	190	400.0	2581	225.0	852.0	69	55							
	RL-2+	L-3+T	N	22.0-3.0	27.3	693	68.8	1748	30.3	770	30.5	775	305	190	456.0	2942	237.6	894.4	56	44			75	110	70	100	
	RL-2F	L-2		22.0-3.0	27.5	699	68.8	1748	30.9	785	30.7	780	305	190	416.0	2683	240.4	909.9	43	34			100	150	95	140	
	RL-3S	L-3S	E	22.0-3.0	27.8	707	68.9	1750	29.7	754	30.3	769	305	189	410.0	2645	250.0	946.0	56	44							
	RL-4K	L-4		22.0-3.0	27.7	703	70.2	1783	30.8	782	31.3	795	299	186	508.9	3283	250.0	946.0	67	53					75	109	
	RL-4K (24/24)	L-4		22.0-3.0	27.7	703	70.2	1783	30.8	782	31.6	803	299	186	459.0	2961	219.0	829.0	67	53			80	120	75	110	
	RL-4S	L-4S		22.0-3.0																							
	RL-5K	L-5		22.0-3.0	27.7	703	70.2	1783	30.8	782	31.6	803	299	186	459.0	2961	219.0	829.0	110	87							
	RL-5K (03/03)	L-5	N	22.00-3.0	27.7	703	70.2	1783	30.8	782	31.6	803	299	186	459.0	2961	219.0	829.0	110	87							
	RL-5K (08/08)	L-5		22.0-3.0	27.7	703	70.2	1783	30.8	782	31.6	803	299	186	459.0	2961	219.0	829.0	110	87							
	RL-5K (12/12)	L-5		22.0-3.0	27.7	703	70.2	1783	30.8	782	31.6	803	299	186	459.0	2961	219.0	829.0	110	87							
	RL-5K (24/24)	L-5	N E A	22.0-3.0	27.7	703	70.2	1783	30.8	782	31.6	803	299	186	459.0	2961	219.0	829.0	110	87			^65	^100	95	90	
	RL-5K 00/23	L-5		22.0-3.0	27.7	703	70.2	1783	30.8	782	31.6	803	299	186	459.0	2961	219.0	829.0	110	87							
	RT-3B	L-3	N E	22.0-3.0	27.4	695	68.6	1741	30.4	773	30.1	765	306	190	462.0	2981	250.0	946.0	50	40							
	RT-5C	L-5	E	22.0-3.0	26.7	678	70.7	1796	30.5	775	31.5	799	297	185	453.0	2920			105	83							
RT-5D Hi-Stability	L-5	N L E A	22.00-3.0	27.9	709	70.5	1791	31.3	795	31.6	803	299	185.8	508.9	3283	225.0	852.0	111	87.9								
SM-5A	L-5S	E A	22.0-3.0	27.7	703	70.2	1783	30.8	782	31.6	803	299	186	459.0	2961	219.0	829.0	110	87								
TL-3A+	L-3+T	N	E	22.0-3.0	27.5	699	69.0	1753	30.2	767	30.3	770	305	189	484.0	3121	250.0	946.0	59	47							

Sizes in bold type can be obtained in locations in bold.
 Extended lead time may be needed in other locations.

Legend	N = North America	E = Europe / Africa / Mid East	# = Estimated Data	^ = Work Capability Factor
	L = Latin America	A = Asia / Australia	* = Tube Type Tire	

LOAD LIMITS AT COLD INFLATION PRESSURES

5 MPH (10 KM/H) MAXIMUM SPEED OFF-THE-ROAD SLOW SPEED SERVICE

RADIAL	PSI	29	33	36	40	44	47	51	54	58	62	65	69	73	76	80	
	KPA	200	225	250	275	300	325	350	375	400	425	450	475	500	525	550	Continued
26.5R25	LBS	16500	18200	19800	20900	22700	24000	25400	26800	28300	29100	30900	32000	33100*	34200	35300	
	KG	7500	8250	9000	9500	10300	10900	11500	12150	12850	13200	14000	14500	15000*	15500	16000	
	PSI	83	87	91	94	116											
	KPA	575	600	625	650	800											
	LBS	36400	37500	39700	40800**	46700***											
	KG	16500	17000	18000	18500**	21800***											

5 MPH (10 KM/H) OFF-THE-ROAD UNDERGROUND MINE SERVICE

RADIAL	PSI	29	33	36	40	44	47	51	54	58	62	65	69	73	76	80	
	KPA	200	225	250	275	300	325	350	375	400	425	450	475	500	525	550	Continued
26.5R25	LBS	16500	18200	19800	20900	22700	24000	25400	26800	28300	29100	30900	32000	33100*	34200	35300	
	KG	7500	8250	9000	9500	10300	10900	11500	12150	12850	13200	14000	14500	15000*	15500	16000	
	PSI	83	87	91	94	116											
	KPA	575	600	625	650	800											
	LBS	36400	37500	39700	40800**	46700***											
	KG	16500	17000	18000	18500**	21800***											

Legend

▲ Permafoam inflation or special rim required

WIDE BASE SIZE

LOAD LIMITS AT COLD INFLATION PRESSURES

5 MPH (10 KM/H) MAXIMUM SPEED OFF-THE-ROAD SLOW SPEED SERVICE

	PSI	33	36	40	44	47	51	54	58	62	65	69	73	76
BIAS	KPA	225	250	275	300	325	350	375	400	425	450	475	500	525
29.5-25	LBS	26800	28300(16)	30000	32000	33100(22)	35300	36400	37500	38600(28)	40800	41900	43000	44100(34)
	KG	12150	12850(16)	13600	14500	15000(22)	16000	16500	17000	17500(28)	18500	19000	19500	20000(34)

30 MPH (50 KM/H) MAXIMUM SPEED OFF-THE-ROAD HAULAGE SERVICE

	PSI	25	29	33	36	40	44	47	51	54	58
BIAS	KPA	175	200	225	250	275	300	325	350	375	400
29.5-25	LBS	17600	19300	20400	22000(22)	23400	24000	25400(28)	26800	27600	29100(34)
	KG	8000	8750	9250	10000(22)	10600	10900	11500(28)	12150	12500	13200(34)

30 MPH (50 KM/H) MAXIMUM SPEED OFF-THE-ROAD SAND SERVICE

	PSI	11	15	18	22	25	29	33	36
BIAS	KPA	75	100	125	150	175	200	225	250
29.5-25	LBS	10470	12350	13890	15650	17090	18190	19840	20940
	KG	4750	5600	6300	7100	7750	8250	9000	9500

40 MPH (65 KM/H) MAXIMUM SPEED OFF-THE-ROAD SAND SERVICE

	PSI	11	15	18	22	25	29	33	36
BIAS	KPA	75	100	125	150	175	200	225	250
29.5-25	LBS	8540	10200	11680	12790	14330	15210	16530	17640
	KG	3875	4625	5300	5800	6500	6900	7500	8000

Legend

▲ Permafoam inflation or special rim required

WIDE BASE SIZE

WIDE BASE SIZE

RADIAL

DIMENSIONAL DATA



Size	Type	Ind Code	Current In Line Location		Rim Width & Flange	INFLATED DIMENSIONS		LOADED DIMENSIONS		Revol Per		Gross Contact Area		Tire Volume		Tread Depth		PERFORMANCE CAPABILITY									
						Overall Width	Overall Diameter	Load Sect & Growth	Static Load Rad									2S		4S		6S					
						in	mm	in	mm	in	mm	in ²	cm ²	gal	ltrs	in	mm	tmph	tkph	tmph	tkph	tmph	tkph				
29.5R25	EV-3B	IND-3			25.00-3.5	30.5	775	73.1	1857	34.6	879	32.2	817	288	179	505.0	3258	307.7	1164.6	48	38						
	GP-2B	E-3	N	A	25.00-3.5	30.5	775	73.1	1857	33.9	861	33.0	837	288	179	418.0	2697	307.7	1164.6	48	38	235	340	185	270	155	230
	GP-4B AT	E-4	N	E A	25.00-3.5	29.2	742	73.5	1866	33.9	861	32.8	833	284	177	542.0	3497	300.0	1136.0	72	57	165	240	130	190	105	150
	GP-4D #	E-4		E	25.00-3.5	29.9	760	73.6	1870			32.6	829	285	177			300.0	1136.0	72	57	170#	245#	135#	195#	115#	165#
	GP-4D Hi-Stability	E-4		E	25.00-3.5	29.9	760	73.6	1870			32.6	829	285	177			300.0	1136.0	72	57	170	245	135	195	115	165
	GT-4A #	E-4	N	A	25.00-3.5	30.4	772	74.5	1892	34.3	871	32.6	827	282	175	522.8	3373	297.0	1125.0	76	60	160#	230#	125#	180#	100#	150#
	RL-2+	E-3+T	N	A	25.00-3.5	30.9	785	74.0	1880	33.4	848	33.9	861	284	176	447.0	2884	315.1	1192.7	60	48	185	270	140	200		
	RL-2F	E-2			25.00-3.5	30.7	780	73.1	1857	33.9	861	33.9	861	288	179	410.0	2645	307.8	1165.1	44	35	220	320	160	230		
	RT-3B	G-3		E	25.00-3.5	29.9	760	73.1	1857			32.4	823	289	180	523.0	3373			55	44					^90	^130
	TL-3A+ #	E-3+T	N	E	25.00-3.5	31.0	787	74.0	1880	34.1	866	33.7	856	284	176	496.0	3201	312.0	1180.0	60	48	185#	270#	150#	215#	125#	185#

Loader tires for this size are located on page 101

Sizes in bold type can be obtained in locations in bold. Extended lead time may be needed in other locations.

Legend	N = North America	E = Europe / Africa / Mid East	# = Estimated Data	^ = Work Capability Factor
	L = Latin America	A = Asia / Australia	* = Tube Type Tire	

LOAD LIMITS AT COLD INFLATION PRESSURES

25 MPH (40 KM/H) MAXIMUM SPEED OFF-THE-ROAD TRACTOR AND GRADER SERVICE

30 MPH (50 KM/H) MAXIMUM SPEED OFF-THE-ROAD HAULAGE SERVICE

RADIAL	PSI	40	44	47	51	54	58	62	65	69	73	76
	KPA	275	300	325	350	375	400	425	450	475	500	525
29.5R25	LBS	18700	20400	21500	22700	24000*	25400	26000	27600	28300	30000	30900**
	KG	8500	9250	9750	10300	10900*	11500	11800	12500	12850	13600	14000**

30 MPH (50 KM/H) MAXIMUM SPEED OFF-THE-ROAD ARTICULATED DUMP SERVICE

RADIAL	PSI	29	33	36	40	44	47	51	54	58	62	65
	KPA	200	225	250	275	300	325	350	375	400	425	450
29.5R25	LBS	16500	18200	19800	20900	22700	24000*	25400	26800	28300	29100	30900**
	KG	7500	8250	9000	9500	10300	10900*	11500	12150	12850	13200	14000**

30 MPH (50 KM/H) (50kph) MAXIMUM SPEED OFF-THE-ROAD HAULAGE SERVICE

30 MPH (50 KM/H) 50KPH MAXIMUM SPEED OFF-THE-ROAD SERVICE

Legend

▲ Permafoam inflation or special rim required

WIDE BASE SIZE

WIDE BASE SIZE

RADIAL

DIMENSIONAL DATA



Size	Type	Ind Code	Current In Line Location	Rim Width & Flange	INFLATED DIMENSIONS				LOADED DIMENSIONS				Gross Contact Area		Tire Volume		Tread Depth		PERFORMANCE CAPABILITY									
					Overall Width in	mm	Overall Diameter in	mm	Load Sect in	Growth mm	Static Load Rad in	mm	Revol Per mi	km	in2	cm2	gal	ltrs	1/32 in	mm	2S tmph	tkph	4S tmph	tkph	6S tmph	tkph		
29.5R25	GP-2B	L-3	N	25.00-3.5	30.1	765	73.1	1857	34.1	866	31.6	803	288	179	597.0	3852	307.7	1164.6	48	38			155	230	130	190		
	GP-4B AT	L-4	A	25.00-3.5	29.3	744	73.4	1864	34.4	874	32.1	817	286	178	595.0	3839	300.0	1136.0	72	57								
	GP-4D #	L-4	E	25.00-3.5	29.9	760	73.6	1870			32.2	819	285	177			300.0	1136.0	72	57					^85#	^120#		
	GP-4D Hi-Stability #	L-4	E	25.00-3.5	29.9	760	73.6	1870			32.2	819	285	177			300.0	1136.0	72	57							85#	120#
	GT-4A #	L-4	N A	25.00-3.5	30.4	772	74.5	1892	34.3	871	32.6	827	282	175	522.8	3373	297.0	1125.0	76	60	160#	230#	125#	180#	100#	150#		
	RL-2+	L-3+T	N	25.00-3.5	30.9	785	74.0	1880	34.2	869	32.9	834	284	176	514.0	3316	315.1	1192.7	60	48			^85	^120	^80	^120		
	RL-2F	L-2		25.00-3.5	30.7	780	73.1	1857	34.6	879	32.2	817	288	179	498.0	3213	307.8	1165.1	44	35			115	170	110	160		
	RL-4K (24/24)	L-4	N E	25.00-3.5	30.4	771	75.7	1923	33.6	853	33.0	839	278	173	583.0	3758	325.0	1230.0	72	57			^90	^130	^85	^120		
	RL-4S Hi-Stability #	L-4S	L	25.0x25	30.4	771	75.7	1923	33.6	853	33.0	839	277.5	172.4	582.5	3758	325.0	1230.0	72	57.2								
	RL-5K (24/24)	L-5	N E A	25.00-3.5	31.7	805	75.6	1920	34.9	887	33.9	861	278	173	468.0	3019	273.7	1036.1	120	95			^70	^100	^65	^100		
	RL-5S	L-5S	N E	25.00-3.5	31.7	805	75.6	1920	34.9	887	33.9	861	278	173	467.9	3019			122	97								
	RT-3B	L-3	E	25.00-3.5	29.9	760	73.1	1857			32.4	823	289	180	523.0	3373			55	44							^90	^130
	RT-5D Hi-Stability	L-5	N L E A	25.00-3.5	31.7	805	75.6	1920	34.9	887	33.9	861	277.9	172.7	468.0	3019	300.0	1136.0	120	95.3			^110	^160	^90	101	0	
TL-3A+	L-3+T	N E	25.00-3.5	31.0	788	74.0	1880	35.2	894	32.7	831	284	176	592.0	3818	312.0	1180.0	60	48					^95	^140			

Sizes in bold type can be obtained in locations in bold. Extended lead time may be needed in other locations.

Legend	N = North America L = Latin America	E = Europe / Africa / Mid East A = Asia / Australia	# = Estimated Data * = Tube Type Tire	^ = Work Capability Factor
---------------	--	--	--	----------------------------

LOAD LIMITS AT COLD INFLATION PRESSURES

5 MPH (10 KM/H) MAXIMUM SPEED OFF-THE-ROAD SLOW SPEED SERVICE

RADIAL	PSI	58	62	65	69	73	76	80	83	87	91	94	116
	KPA	400	425	450	475	500	525	550	575	600	625	650	800
29.5R25	LBS	34200	35300	37500	38600	39700*	41900	43000	44100	45400	46700	49400**	56800***
	KG	15500	16000	17000	17500	18000*	19000	19500	20000	20600	21200	22400**	25750***

5 MPH (10 KM/H) OFF-THE-ROAD UNDERGROUND MINE SERVICE

Legend ▲ Permafoam inflation or special rim required

WIDE BASE SIZE

WIDE BASE SIZE

DIMENSIONAL DATA

RADIAL

BIAS



RL-2F RL-3S SGL D/L-2A SHRL DL SHRL SHRL XT D/L SMO D/L-5A SMO D/L-5C SMO-5C SMO D/L-4A HRL D/L-5C SXT DL HRL D/L-3A HRL-3A

Size	Type	Ind Code	Current In Line Location	Rim Width & Flange	INFLATED DIMENSIONS		LOADED DIMENSIONS		Revol Per mi km	Gross Contact Area		Tire Volume		Tread Depth		PERFORMANCE CAPABILITY										
					Overall Width in mm	Overall Diameter in mm	Load Sect & Growth in mm	Static Load Rad in mm		in ²	cm ²	gal	ltrs	1/32 in	mm	2S		4S		6S						
																tmph	tkph	tmph	tkph	tmph	tkph					
26.5-29	SGL D/L-2A	L-2	L	22.0-3.0	27.2	691	72.8	1849	30.0	762	32.2	818	292	181	471.0	3039	45	36	^70	^100						
	SGL-2A	E-2		22.0-3.0	27.0	686	73.1	1857	29.1	739	32.9	836	286	178	438.0	2826	43	34	120	180						
	SHRL	E-3		22.0-3.0	27.0	686	73.1	1857	29.1	739	32.9	836	286	178	438.0	2826	45	36	110	160						
26.5R29	RL-2F	E-2	E	22.00-3.0	27.1	688	72.4	1839	29.9	759	33.0	838	290	180	380.0	2452	254.3	962.4	43	34	195	280	145	210		
	RL-2F	L-2		22.00-3.0	27.1	688	72.4	1839	31.0	788	32.0	813	290	180	440.0	2838	254.3	962.4	43	34	110	160	105	153		
	RL-3S	L-3S		22.00-3.0	29.0	737	73.4	1864	30.4	772	32.5	825	286	178	410.0	2645	305.0	1155.0	56	44						
29.5-29	AMS D/L-5/8H	L-5	N L A	25.00-3.5	29.9	759	78.8	2002	32.5	826	36.8	935	256	159	486.0	3136			126	99	55	80	50	70		
	DRL D/L-5A	L-5		25.00-3.5	30.0	762	78.9	2004	32.5	826	36.8	935	256	159	496.0	3200			128	102	70	100	65	100		
	HRL D/L-3A	L-3		25.00-3.5	30.5	775	77.1	1958	33.7	856	34.6	879	272	169	587.0	3787	308.8	1168.9	52	41	^80	^120				
	HRL D/L-5C	L-5		25.00-3.5	30.1	765	78.9	2004	33.0	838	36.3	922	259	161	560.0	3613			117	93						
	HRL-3A	E-3		25.00-3.5	30.3	770	77.1	1958	32.7	831	34.4	874	273	170	476.0	3071	308.8	1168.9	52	41	175	260	125	180	103	
	SGL-2A	E-2		25.00-3.5	30.3	770	77.1	1958	32.7	831	34.4	874	273	170	476.0	3071	267.0	1012.0	47	37			135	200		
	SHRL	E-3		25.00-3.5	30.3	770	77.1	1958	32.7	831	34.4	874	273	170	476.0	3071	308.8	1168.9	52	41	175	260	125	180		
	SHRL	L-3		25.00-3.5	30.3	770	77.1	1958	33.3	846	33.6	853	280	174	625.0	4033	268.0	1014.4	47	37			100	150		
	SHRL DL	L-3		25.00-3.5	30.5	775	77.1	1958	33.7	856	34.6	879	272	169	587.0	3787	308.8	1168.9	52	41			80	120		
	SHRL XT D/L	L-4		25.00-3.5	30.8	782	78.7	1999	34.1	866	35.6	904	264	164	568.0	3665	273.3	1034.7	77	61			75	110	70	100
	SMO D/L-4A	L-4S		25.00-3.5	31.3	795	78.2	1986	34.9	886	35.7	907	259	161	512.0	3303			74	58			^65	^100		
	SMO D/L-5A	L-5S		25.00-3.5	30.1	765	78.9	2004	33.0	838	36.3	922	259	161	566.0	3652	268.6	1016.7	137	108			55	80	50	70
	SMO D/L-5C	L-5S		25.00-3.5																						
	SMO-5C	L-5S		25.00-3.5	A	30.1	765	78.9	2004	33.0	838	36.3	922	259	161	566.0	3652	268.6	1016.7	137	108			^55	^80	^50
SXT DL	L-5	25.00-3.5	N L A	30.1	765	78.9	2004	33.0	838	36.3	922	259	161	566.0	3652	261.0	988.0	128	102			^70	^100	^65	^100	

Sizes in bold type can be obtained in locations in bold. Extended lead time may be needed in other locations.

Legend	N = North America	E = Europe / Africa / Mid East	# = Estimated Data	^ = Work Capability Factor
	L = Latin America	A = Asia / Australia	* = Tube Type Tire	

LOAD LIMITS AT COLD INFLATION PRESSURES

5 MPH (10 KM/H) MAXIMUM SPEED OFF-THE-ROAD SLOW SPEED SERVICE

		PSI	33	36	40	44	47	51	54	58	62	65	69	73	76			
BIAS		KPA	225	250	275	300	325	350	375	400	425	450	475	500	525			
26.5-29	LBS		24000	25400	26800	28300	30000	30900	32000(22)	33100	34200	35300(26)	37500	38600	39700(30)			
	KG		10900	11500	12150	12850	13600	14000	14500(22)	15000	15500	16000(26)	17000	17500	18000(30)			
RADIAL	PSI		58	62	65	69	73	76	80	83	87	91	94					
	KPA		400	425	450	475	500	525	550	575	600	625	650					
26.5R29	LBS		30000	30900	33100	34200	35300*	36400	38600	39700	40800	41900	43000**					
	KG		13600	14000	15000	15500	16000*	16500	17500	18000	18500	19000	19500**					
BIAS	PSI		33	36	40	44	47	51	54	58	62	65	69	73	76	80	83	Continued
	KPA		225	250	275	300	325	350	375	400	425	450	475	500	525	550	575	
29.5-29	LBS		28300	30900	32000	34200	35300(22)	37500	38600	39700	41900(28)	43000	44100	45400	46700(34)	48100	49400	
	KG		12850	14000	14500	15500	16000(22)	17000	17500	18000	19000(28)	19500	20000	20600	21200(34)	21800	22400	
	PSI		87	91														
	KPA		600	625														
	LBS		50700	52000(40)														
	KG		23000	23600(40)														

30 MPH (50 KM/H) MAXIMUM SPEED OFF-THE-ROAD HAULAGE SERVICE

		PSI	25	29	33	36	40	44	47								
BIAS		KPA	175	200	225	250	275	300	325								
26.5-29	LBS		15700	17100	18200	19300	20400(22)	21500	22700(26)								
	KG		7100	7750	8250	8750	9250(22)	9750	10300(26)								
RADIAL	PSI		40	44	47	51	54	58	62	65	69	73	76				
	KPA		275	300	325	350	375	400	425	450	475	500	525				
26.5R29	LBS		16500	17600	18700	19800	20900*	22000	23400	24000	25400	26000	27600**				
	KG		7500	8000	8500	9000	9500*	10000	10600	10900	11500	11800	12500**				
BIAS	PSI		25	29	33	36	40	44	47	51	54	58					
	KPA		175	200	225	250	275	300	325	350	375	400					
29.5-29	LBS		18700	20400	22000	23400(22)	24700	26000	26800(28)	28300	29100	30900(34)					
	KG		8500	9250	10000	10600(22)	11200	11800	12150(28)	12850	13200	14000(34)					

Legend ▲ Permafoam inflation or special rim required

WIDE BASE SIZE

WIDE BASE SIZE

RADIAL

DIMENSIONAL DATA

BIAS



Size	Type	Ind Code	Current In Line Location		Rim Width & Flange	INFLATED DIMENSIONS		LOADED DIMENSIONS		Revol Per mi km	Gross Contact Area		Tire Volume		Tread Depth		PERFORMANCE CAPABILITY										
						Overall Width in mm	Overall Diameter in mm	Load Sect & Growth in mm	Static Load Rad in mm		in ²	cm ²	gal	ltrs	1/32 in	mm	2S		4S		6S						
29.5R29	RL-2+	E-3+T	N	A	25.00-3.5	30.4	772	78.6	1996	34.0	864	36.0	914	267	166	525.0	3387	342.6	1296.8	60	48	210	310	160	230		
	RL-2+	G-3+T	N	A	25.00-3.5	30.4	772	78.6	1996	34.0	864	36.0	914	267	166	525.0	3387	342.6	1296.8	60	48	210	310	160	230		
	RL-2+	L-3+T	N		25.00-3.5	30.4	772	78.6	1996	34.7	881	34.2	869	267	166	575.0	3710	342.6	1296.8	60	48			[^] 100	[^] 150	[^] 95	[^] 140
	RL-2F	E-2			25.00-3.5	30.3	770	77.0	1956	33.4	848	35.2	894	273	170	480.0	3097	334.3	1265.4	44	35	260	380	195	280		
	RL-2F	L-2			25.00-3.5	30.3	770	77.0	1956	34.0	864	34.6	879	273	170	535.0	3452	334.3	1265.4	44	35			120	180	115	170
	RL-3	E-3			25.00-3.5	30.5	775	77.0	1956	33.5	851	35.2	894	272	169	492.0	3174	338.5	1281.0	47	37	185	270				
	RL-4K (24/24)	L-4	N	A	25.00-3.5	30.7	779	79.7	2024	34.6	879	35.0	890	264	164	554.0	3571	350.0	1325.0	72	57			100	150	95	140
	RL-5K (24/24)	L-5	N		25.00-3.5	30.1	764	79.7	2024	34.2	869	35.0	890	264	164	554.0	3571	325.0	1230.0	120	95			[^] 80	[^] 120	[^] 75	[^] 110
RL-5S #	L-5S			25.00-3.5	30.1	764	79.7	2024	34.2	869	35.0	890	264	164	554.0	3571	325.0	1230.0	120	95							
33.25-29	SHRL8	E-3			27.00-3.5	33.6	853	81.9	2080	37.2	945	36.4	925	256	159	652.0	4207	288.0	1090.7	54	43			140	200		
33.25R29	RL-2F	E-2			27.00-3.5	34.2	869	82.2	2089	35.5	902	37.0	940	256	159	570.0	3677	437.2	1654.8	53	42	275	400	210	310		
	RL-2F	L-2			27.00-3.5	34.2	869	82.2	2089	37.0	940	36.0	914	256	159	690.0	4452	437.2	1654.8	53	42						
	RT-3A	E-3	N		27.00-3.5	34.2	869	82.2	2089	35.5	902	37.0	940	248	154	600.0	3871	437.2	1654.8	53	42	285	420	220	320		
	TL-3A #	E-3	N		27.00 x 3.5	34.0	864	82.2	2088	38.5	978	36.0	915	255.6	158.8	645.8	4166	425.0	1609.0	57	45	255#	370#	205#	300#	170	105 #
	TL-4A #	E-4	N		27.00 x 3.5	34.0	864	82.2	2088	38.5	978	36.0	915	255.6	158.8	645.8	4166	425.0	1609.0	81	64	185#	270#	150#	215#	125#	185#
24.5-32	* American Log Skidder	LS-2	N	L E A	DH21B, DH21H	24.5	645	72.0	1829											68	54						

Sizes in bold type can be obtained in locations in bold. Extended lead time may be needed in other locations.

<u>Legend</u>	N = North America L = Latin America	E = Europe / Africa / Mid East A = Asia / Australia	# = Estimated Data * = Tube Type Tire	^ = Work Capability Factor
---------------	--	--	--	----------------------------

LOAD LIMITS AT COLD INFLATION PRESSURES

5 MPH (10 KM/H) MAXIMUM SPEED OFF-THE-ROAD SLOW SPEED SERVICE

	PSI	58	62	65	69	73	76	80	83	87	91	94	116
RADIAL	KPA	400	425	450	475	500	525	550	575	600	625	650	800
29.5R29	LBS	36400	37500	39700	40800	43000*	44100	45400	46700	49400	50700	52000**	60000***
	KG	16500	17000	18000	18500	19500*	20000	20600	21200	22400	23000	23600**	27250***
	PSI	33	36	40	44	47	51	54	58	62	65		
BIAS	KPA	225	250	275	300	325	350	375	400	425	450		
33.25-29	LBS	35300	37500	38600(20)	40800	43000	45400(26)	46700	48100	50700	52000(32)		
	KG	16000	17000	17500(20)	18500	19500	20600(26)	21200	21800	23000	23600(32)		
	PSI	58	62	65	69	73	76	80	83	87	91	94	
RADIAL	KPA	400	425	450	475	500	525	550	575	600	625	650	
33.25R29	LBS	44100	46700	48100	50700	52000*	53600	56800	58400	60000	61500	64000**	
	KG	20000	21200	21800	23000	23600*	24300	25750	26500	27250	28000	29000**	

25 MPH (40 KM/H) MAXIMUM SPEED OFF-THE-ROAD TRACTOR AND GRADER SERVICE

	PSI	25	29	33	36	40	44	47	51	54	58	62	65
RADIAL	KPA	175	200	225	250	275	300	325	350	375	400	425	450
29.5R29	LBS	14300	15700	17100	18700	20400	21500*	22700	24000	25400	26800	27600	29100**
	KG	6500	7100	7750	8500	9250	9750*	10300	10900	11500	12150	12500	13200**

30 MPH (50 KM/H) MAXIMUM SPEED OFF-THE-ROAD HAULAGE SERVICE

	PSI	40	44	47	51	54	58	62	65	69	73	76
RADIAL	KPA	275	300	325	350	375	400	425	450	475	500	525
29.5R29	LBS	20400	21500	22700	24000	25400*	26800	27600	29100	30000	32000	33100**
	KG	9250	9750	10300	10900	11500*	12150	12500	13200	13600	14500	15000**
33.25R29	LBS	24700	26800	28300	30000	30900*	33100	34200	36480	37500	38600	40800**
	KG	11200	12150	12850	13600	14000*	15000	15500	16500	17000	17500	18500**
	PSI	25	29	33	36	40	44	47				
BIAS	KPA	175	200	225	250	275	300	325				
33.25-29	LBS	22700	24700	26800	28300	30000(26)	30900	33100(32)				
	KG	10300	11200	12150	12850	13600(26)	14000	15000(32)				

Legend

▲ Permafoam inflation or special rim required

WIDE BASE SIZE

WIDE BASE SIZE

BIAS



DIMENSIONAL DATA

Size	Type	Ind Code	Current In Line Location		Rim Width & Flange	INFLATED DIMENSIONS				LOADED DIMENSIONS				Gross Contact Area		Tire Volume		Tread Depth		PERFORMANCE CAPABILITY														
						Overall Width		Overall Diameter		Load Sect & Growth		Static Load Rad								Revol Per	mi	km	in2	cm2	gal	ltrs	in	mm	2S		4S		6S	
						in	mm	in	mm	in	mm	in	mm																mi	km	in2	cm2	gal	ltrs
33.5-33	HRL-3F	E-3	N	A	28.00-4.0	34.2	869	87.7	2228	36.8	935	40.0	1016	235	146	609.0	3929	443.8	1679.9	63	50			160	230									
	SHRL	E-3			28.00-4.0	34.3	871	87.1	2212	36.6	930	39.0	991	239	149	590.0	3807			53	42													
	SHRL XT D/L	L-4	N	L	28.00-4.0	34.2	869	90.6	2301	39.6	1006	40.5	1029	231	144	887.0	5723	416.0	1574.0	87	69			90	130									
	SHRL8	E-3			28.00-4.0	34.2	869	88.3	2243	36.8	935	39.7	1008	235	146	609.0	3929			59	47			170	250									
	SHRL8 DL	L-3			28.00-4.0	34.2	869	87.7	2228	37.3	947	38.8	986	241	150	788.0	5084	374.0	1415.6	59	47			^105	^150									
37.5-33	HRL-3F	E-3	N	A	32.00-4.5	40.3	1024	93.3	2370	43.1	1095	41.8	1062	223	139	814.0	5252			67	53			210	310									
	SGL-2A	E-2			32.00-4.5	38.9	988	93.7	2380	41.8	1062	41.6	1057	225	140	737.0	4755			57	45			220	320									
	SHRL8	E-3			32.00-4.5	38.9	988	93.2	2367	42.3	1074	41.8	1062	223	139	814.0	5252	452.0	1711.0	61	48			220	320									
	SHRL8 DL	L-3			32.00-4.5	39.5	1003	93.3	2370	42.3	1074	41.8	1062	223	139	814.0	5252	452.0	1711.0	61	48			^130	^190									
29.5-35	SGL-2A	E-2			25.00-3.5	29.6	752	83.4	2118	32.3	820	37.7	958	250	155	537.0	3465	281.3	1064.7	47	37			170	250									
	SHRL	E-3			25.00-3.5	29.6	752	83.4	2118	32.3	820	37.7	958	250	155	537.0	3465	278.0	1052.3	49	39			145	210									
	SHRL8	E-3			25.00-3.5	29.7	754	83.3	2116	32.0	813	37.5	953	251	156	522.0	3368			51	40			160	230									
33.25-35	HRL D/L-3F	L-3			27.00-3.5	34.1	865	88.7	2252	37.6	955	39.4	1000	236	147	760.0	4904			63	50													
	HRL-3F	E-3	N	A	27.00-3.5	33.7	856	87.5	2223	36.8	935	39.8	1011	237	147	627.0	4045	428.1	1620.5	63	50			160	230									
	SHRL XT D/L	L-4			27.00-3.5	33.1	841	91.1	2314	37.1	942	41.6	1057	225	140	730.0	4710	348.0	1317.2	87	69			95	140									
	SHRL8	E-3	N	L	27.00-3.5	33.7	856	88.2	2240	36.4	925	39.3	998	238	148	616.0	3974			56	44													
	SHRL8	E-3			27.00-3.5	33.7	856	88.4	2245	36.8	935	39.4	1001	237	147	627.0	4045			54	43			170	250									
	SHRL8 DL	L-3			27.00-3.5	33.7	856	87.5	2223	37.4	950	38.5	978	243	151	782.0	5045	374.7	1418.1	54	43			^110	^160									
	SMO D/L-5A	L-5S			27.00-3.5	32.9	836	91.1	2314	36.2	920	42.1	1069	222	138	767.0	4949			137	108			70	100									
SXT DL	L-5			27.00-3.5	32.9	836	91.1	2314	36.2	920	42.1	1069	222	138	767.0	4949	326.7	1236.4	142	113			80	120	75	110								

Sizes in bold type can be obtained in locations in bold. Extended lead time may be needed in other locations.

Legend	N = North America	E = Europe / Africa / Mid East	# = Estimated Data	^ = Work Capability Factor
	L = Latin America	A = Asia / Australia	* = Tube Type Tire	

LOAD LIMITS AT COLD INFLATION PRESSURES

5 MPH (10 KM/H) MAXIMUM SPEED OFF-THE-ROAD SLOW SPEED SERVICE

	PSI	44	47	51	54	58	62	65	69	73	76	80	83	87	
BIAS	KPA	300	325	350	375	400	425	450	475	500	525	550	575	600	
33.5-33	LBS	45400	48100	49400	52000	53600	56800(32)	58400	60000	61500	64000(38)	66000	66000	68000(44)	
	KG	21800	21800	22400	23600	24300	25750(32)	26500	27250	28000	29000(38)	30000	30000	30750(44)	
BIAS	PSI	33	36	40	44	47	51	54	58	62	65	69	73	76	
	KPA	225	250	275	300	325	350	375	400	425	450	475	500	525	
37.5-33	LBS	46700	49400	52000	55100	56800	60000	61500(30)	64000	68000	69500(36)	71500	74000	76000(42)	
	KG	21200	22400	23600	25000	25750	27250	28000(30)	29000	30750	31500(36)	32500	33500	34500(42)	
29.5-35	LBS	30900	33100	35300	37500	38600	40800	41900	44100	45400(28)	46700	48100	49400	50700(34)	
	KG	14000	15000	16000	17000	17500	18500	19000	20000	20600(28)	21200	21800	22400	23000(34)	
BIAS	PSI	33	36	40	44	47	51	54	58	62	65	69	73	76	
	KPA	225	250	275	300	325	350	375	400	425	450	475	500	525	
33.25-35	LBS	37500	39700	41900(20)	44100	46700	49400(26)	50700	53600	55100	56800(32)	58400	60000	61500(38)	74000(50)
	KG	17000	18000	19000(20)	20000	21200	22400(26)	23000	24300	25000	25750(32)	26500	27250	28000(38)	33500(50)

30 MPH (50 KM/H) MAXIMUM SPEED OFF-THE-ROAD HAULAGE SERVICE

	PSI	25	29	33	36	40	44	47	51	54	58					
BIAS	KPA	175	200	225	250	275	300	325	350	375	400					
33.5-33	LBS	25400	27600	29100	30900	33100	35300	36400(32)	38600	39700	40800(38)					
	KG	11500	12500	13200	14000	15000	16000	16500(32)	17500	18000	18500(38)					
37.5-33	LBS	30900	33100	35300	37500	39700(30)	41900	44100(36)	45500	48100	49400(42)					
	KG	14000	15000	16000	17000	18000(30)	19000	20000(36)	20600	21800	22400(42)					
29.5-35	LBS	20400	22000	24000	25400	26800	28300	30000(28)	30900	32000	33100(34)					
	KG	9250	10000	10900	11500	12150	12850	13600(28)	14000	14500	15000(34)					
BIAS	PSI	25	29	33	36	40	44	47	51	54	58	62	65	69	73	76
	KPA	175	200	225	250	275	300	325	350	375	400	425	450	475	500	525
33.25-35	LBS	24700	26800	28300	30900	32000	34200	35300(32)	37500	38600	39700(38)	41900	43000	44100	45400	46700(50)
	KG	11200	12150	12850	14000	14500	15500	16000(32)	17000	17500	18000(38)	19000	19500	20000	20600	21200(50)

Legend ▲ Permafoam inflation or special rim required

WIDE BASE SIZE

WIDE BASE SIZE

DIMENSIONAL DATA

RADIAL



BIAS



Size	Type	Ind Code	Current In Line Location	Rim Width & Flange	INFLATED DIMENSIONS				LOADED DIMENSIONS				Revol Per mi km	Gross Contact Area		Tire Volume		Tread Depth		PERFORMANCE CAPABILITY						
					Overall Width		Overall Diameter		Load Sect & Growth		Static Load Rad			in ²	cm ²	gal	ltrs	1/32 in	mm	2S		4S		6S		
					in	mm	in	mm	in	mm	in	mm		in	cm	in	mm	in	mm	in	mm	in	mm	in	mm	
33.25R35	RL-2F	E-2		27.00-3.5	33.4	848	87.7	2228	37.4	950	39.0	990	240	149	664.0	4284	454.9	1721.6	53	42	325	470	245	360	145	210
	RL-2F	L-2		27.00-3.5	33.4	848	87.7	2228	38.4	975	37.8	960	240	149	776.0	5006	454.9	1721.6	53	42			150	220		
	RL-3	E-3		27.00-3.5	34.0	864	88.1	2238	37.7	958	40.0	1016	238	148	660.0	4258	486.2	1840.3	53	42			210	310		
	RL-3F	E-3		27.00-3.5	34.5	876	88.2	2240	38.4	976	40.1	1020	238	148	644.0	4154	486.2	1840.3	53	42			210	310		
	RL-3F	L-3		27.00-3.5	34.5	876	88.2	2240	39.0	991	39.0	991	238	148	785.0	5064	486.2	1840.3	53	42						
	RL-3J	E-3	N		27.00-3.5	34.9	886	88.3	2243	38.6	980	39.5	1003	238	148	670.0	4323	486.2	1840.3	53	42			230		
37.25-35	HRL-3F	E-3	N	A	31.00-4.0	39.3	998	94.1	2390	42.7	1085	41.8	1062	223	139	804.0	5187	603.5	2284.4	67	53			210	310	
	HRL-3T #	E-3		A	31.00-4.0	37.6	955	93.0	2362	38.6	980	41.3	1049	224	139	804.0	5187	603.5	2284.4	68	53			215#	315#	
	SHRL8	E-3	N	L	31.00-4.0	38.6	980	94.1	2390	41.9	1064	41.8	1062	223	139	804.0	5187	603.5	2284.4	60	48			220	320	
	SHRL8 DL	L-3	N		31.00-4.0	38.6	980	94.1	2390	40.6	1031	42.9	1090	218	135	986.0	6362			60	48			^130	^190	
	SXT DL	L-5	N		31.00-4.0	37.4	950	95.0	2413	40.0	1016	43.8	1113	213	132	950.0	6129	424.7	1607.4	156	124			^110	^160	
37.25R35	RL-2F	E-2		31.00-4.0	37.0	939	93.0	2361	42.4	1076	41.2	1047	226	140	764.0	4929	604.5	2288.0	58	46	375	550	285	420	109	
	RL-2F	L-2		31.00-4.0	37.0	939	93.0	2361	43.2	1097	40.2	1020	226	140	956.0	6168	604.5	2288.0	58	46			^160	^230		
	RL-3J	E-3	N	A	31.00-4.0	40.0	1016	94.1	2390	44.2	1123	41.8	1062	223	139	750.0	4839	668.8	2531.4	60	48			260		380
	RT-3A+	E-3+		31.00-4.0																						
37.5-39	HRL D/L-5A	L-5		32.00-4.5	38.4	975	100.8	2560	41.9	1064	46.5	1181	201	125	975.0	6290	489.3	1852.1	168	133			115	170		
	HRL-3F	E-3	N	A	32.00-4.5	40.2	1021	99.3	2522	43.1	1095	44.6	1133	209	130	829.0	5349	631.8	2388.0	67	53			225	330	
	SHRL8	E-3	N	L	32.00-4.5	39.5	1003	99.3	2522	42.3	1074	44.6	1133	209	130	829.0	5349			61	48			240	350	
	SHRL8 DL	L-3		32.00-4.5	39.5	1003	99.3	2522	41.0	1041	45.8	1163	204	127	1016.0	6555			61	48						

Sizes in bold type can be obtained in locations in bold. Extended lead time may be needed in other locations.

Legend	N = North America	E = Europe / Africa / Mid East	# = Estimated Data	^ = Work Capability Factor
	L = Latin America	A = Asia / Australia	* = Tube Type Tire	

LOAD LIMITS AT COLD INFLATION PRESSURES

5 MPH (10 KM/H) MAXIMUM SPEED OFF-THE-ROAD SLOW SPEED SERVICE

	PSI	58	62	65	69	73	76	80	83	87	91	94				
RADIAL	KPA	400	425	450	475	500	525	550	575	600	625	650				
33.25R35	LBS	48100	50700	53600	55100	56800*	58400	61500	64000	66000	68000	69500**				
	KG	21800	23000	24300	25000	25750*	26500	28000	29000	30000	30750	31500**				
37.25R35	LBS	58400	60000	64000	66000	68000*	71500	74000	76000	78500	80500	82500**				
	KG	26500	27250	29000	30000	30750*	32500	33500	34500	35500	36500	37500**				
BIAS	PSI	33	36	40	44	47	51	54	58	62	65	69	73	76		
	KPA	225	250	275	300	325	350	375	400	425	450	475	500	525		
37.25-35	LBS	45400	48100	50700	53600	56800	58400	61500(30)	64000	66000	68000(36)	69500	71500	74000(42)		
	KG	20600	21800	23000	24300	25750	26500	28000(30)	29000	30000	30750(36)	31500	32500	33500(42)		
	PSI	44	47	51	54	58	62	65	69	73	76	80	83	87	91	
	KPA	300	325	350	375	400	425	450	475	500	525	550	575	600	625	
37.5-39	LBS	58400	61500	64000	68000	69500	71500	74000(36)	76000	78500	82500	82500(44)	85500	88000	91000	93500(52)
	KG	26500	28000	29000	30750	31500	32500	33500(36)	34500	35500	37500	37500(44)	38750	40000	41250	42500(52)

30 MPH (50 KM/H) MAXIMUM SPEED OFF-THE-ROAD HAULAGE SERVICE

	PSI	40	44	47	51	54	58	62	65	69	73	76			
RADIAL	KPA	275	300	325	350	375	400	425	450	475	500	525			
33.25R35	LBS	26800	28300	30900	32000	34200*	35300	37500	38600	40800	41900	44100**			
	KG	12150	12850	14000	14500	15500*	16000	17000	17500	18500	19000	20000**			
37.25R35	LBS	32000	34200	36400	38600	40800*	43000	45400	46700	49400	50700	52000**			
	KG	14500	15500	16500	17500	18500*	19500	20600	21200	22400	23000	23600**			
BIAS	PSI	25	29	33	36	40	44	47	51	54	58				
	KPA	175	200	225	250	275	300	325	350	375	400				
37.25-35	LBS	30000	32000	34200	36400	38600(30)	40800	43000(36)	44100	46800	48100(42)				
	KG	13600	14500	15500	16500	17500(30)	18500	19500(36)	20000	21200	21800(42)				
	PSI	25	29	33	36	40	44	47	51	54	58	62	65	69	
	KPA	175	200	225	250	275	300	325	350	375	400	425	450	475	
37.5-39	LBS	33100	35300	37500	40800	43000	45400	47000(36)	49400	50700	53600(44)	55100	56800	58400(52)	
	KG	15000	16000	17000	18500	19500	20600	21200(36)	22400	23000	24300(44)	25000	25750	26500(52)	

Legend ▲ Permafoam inflation or special rim required

WIDE BASE SIZE

WIDE BASE SIZE

RADIAL

DIMENSIONAL DATA

BIAS



Size	Type	Ind Code	Current In Line Location		Rim Width & Flange	INFLATED DIMENSIONS				LOADED DIMENSIONS				Gross Contact Area		Tire Volume		Tread Depth		PERFORMANCE CAPABILITY							
						Overall Width		Overall Diameter		Load Sect & Growth		Static Load Rad								Revol Per	mi	km	in2	cm2	gal	ltrs	in
						in	mm	in	mm	in	mm	in	mm	mi	km	in2	cm2	gal	ltrs	in	mm	tmph	tkph	tmph	tkph	tmph	tkph
37.5R39	RL-2F	E-2			32.00-4.5	37.5	953	99.6	2530	42.3	1074	44.7	1135	211	131	785.0	5064	680.7	2576.4	57	45	385	560	285	420		
	RL-2F	L-2			32.00-4.5	37.5	953	99.6	2530	43.6	1107	43.4	1102	211	131	937.0	6045	680.7	2576.4	57	45			^185	^270	^170	^250
	RL-3	E-3			32.00-4.5	38.5	978	100.0	2540	43.1	1095	45.3	1151	210	130	830.0	5355	680.7	2576.4	58	46						
	RL-3J	E-3	N		32.00-4.5	38.8	986	100.0	2540	43.7	1110	45.3	1150	210	130	815.0	5258	680.7	2576.4	58	46			295	430		
40.5/75R39	GP-2B	E-3	N	A	32.00-4.5	40.4	1026	101.4	2576	45.9	1166	44.9	1140	207	129	983.0	6342	798.8	3023.5	58	46	400	580	305	450	240	350
	RL-4K	L-4	N	A	32.00-4.5	40.4	1026	101.4	2576	44.0	1119	44.8	1138	207	129	1093.0	7050	725.0	2744.0	87	70			^140	^200	^125	^180
	RT-3A+	E-3+	N		32.00-4.5	40.8	1036	101.6	2581	46.4	1179	44.9	1140	207	129	984.0	6348	775.0	2934.0	62	49	375	550	290	420	220	320
41.25/70-39	NRL D/L-5A	L-5	N	A	32.00-4.5	42.1	1069	98.4	2499	43.8	1113	44.6	1133	209	130	955.0	6162	549.3	2079.2	145	115			95	140	85	120
37.5-51	HRL D/L-5A	L-5			32.00-4.5	37.8	960	113.8	2891	41.5	1054	53.2	1351	176	109	1063.0	6858	507.3	1920.3	168	133			^170	^250		
	HRL-3B	E-3			32.00-4.5	38.7	983	111.8	2840	42.4	1077	50.7	1288	184	114	996.0	6426			60	48			305	450		
49/75-51	HRL D/L-4B	L-4			36.00-5.0	50.0	1270	127.8	3246	53.9	1369	58.8	1494	159	99	1867.0	12046			114	90						
49.5-57	HRL D/L-4B	L-4			36.00-6.00	49.9	1268	141.8	3601	54.9	1394	61.2	1555	151	94	2169.0	13990	1420.6	5369.8	115	91			200	290	171	111
50/80-57	HRL D/L-4/15C	L-4			36.00-6.00	49.6	1260	140.9	3579	53.2	1352	63.0	1601	148	92	1869.0	12057	1443.0	5454.5	123	97			200	290	150	220
	HRL D/L-4G	L-4			36.00-6.00	49.6	1260	140.9	3579	53.2	1352	63.0	1601	148	92	1869.0	12057	1443.0	5454.5	123	97			200	290	150	220
52/80-57	DRL 4/15C	L-4	N	A	36.00-6.00	52.0	1321	140.9	3579	55.2	1403	63.0	1601	148	92	1958.0	12629			123	97			^165	^240	^120	^175
	HRL D/L-4G	L-4	N	A	36.00-6.00	52.0	1321	140.9	3579	55.2	1403	63.0	1601	148	92	1958.0	12629			123	97	^240	^350	^200	^290	^170	^250

Sizes in bold type can be obtained in locations in bold. Extended lead time may be needed in other locations.

Legend	N = North America	E = Europe / Africa / Mid East	# = Estimated Data	^ = Work Capability Factor
	L = Latin America	A = Asia / Australia	* = Tube Type Tire	

LOAD LIMITS AT COLD INFLATION PRESSURES

5 MPH (10 KM/H) MAXIMUM SPEED OFF-THE-ROAD SLOW SPEED SERVICE

RADIAL	PSI	58	62	65	69	73	76	80	83	87	91	94				
BIAS	KPA	400	425	450	475	500	525	550	575	600	625	650				
37.5R39	LBS	61500	66000	68000	71500	74000*	76000	78500	82500	85500	88000	91000**				
	KG	28000	30000	30750	32500	33500*	34500	35500	37500	38750	40000	41250**				
40.5/75R39	LBS	71500	74000	78500	80500	82500*	88000	91000	93500	96500	99000	102000**				
	KG	32500	33500	35500	36500	37500*	40000	41250	42500	43750	45000	46250**				
BIAS	PSI	44	47	51	54	58	62	65	69	73	76	80				
	KPA	300	325	350	375	400	425	450	475	500	525	550				
41.25/70-39	LBS	64000	66000(34)	69500	71500	74000	78500	80500	82500(42)	85500	88000	91000				
	KG	29000	30000(34)	31500	32500	33500	35500	36500	37500(42)	38750	40000	41250				
37.5-51	LBS	66000	69500	74000	76000	78500	82500	85500(36)	88000	91000	93500	93500(44)				
	KG	30000	31500	33500	34500	35500	37500	38750(36)	40000	41250	42500	42500(44)				
BIAS	PSI	44	47	51	54	58	62	65	69	73	76	80	83	87	94	102
	KPA	300	325	350	375	400	425	450	475	500	525	550	575	600	650	700
49/75-51	LBS	107500	113500	117000	123500(40)	128000	132500	135500(48)	139000	143500(54)	147500	152000	156500(62)	161000	171000(68)	176500(74)
	KG	48750	51500	53000	56000(40)	58000	60000	61500(48)	63000	65000(54)	67000	69000	71000(62)	73000	77500(68)	80000(74)
49.5-57	LBS	128000	132500	139000	143500	152000(44)	156000	161000	165000	171000	176500	182000(60)	187500	187500	193000(68)	
	KG	58000	60000	63000	65000	69000(44)	71000	73000	75000	77500	80000	82500(60)	85000	85000	87500(68)	
50/80-57	LBS	128000	135500	139000	147500	152000(44)	156500	161000	165500	171000	176500	182000(60)	187500	193000	198500(68)	
	KG	58000	61500	63000	67000	69000(44)	71000	73000	75000	77500	80000	82500(60)	85000	87500	90000(68)	
BIAS	PSI	44	47	51	54	58	62	65	69	73	76	80	83	87		
	KPA	300	325	350	375	400	425	450	475	500	525	550	575	600		
52/80-57	LBS	135500	139000	147500	152000	161000(44)	165500	171000	176500	182000	187500	193000	198500	204000(68)		
	KG	61500	63000	67000	69000	73000(44)	75000	77500	80000	82500	85000	87500	90000	92500(68)		

30 MPH (50 KM/H) MAXIMUM SPEED OFF-THE-ROAD HAULAGE SERVICE

RADIAL	PSI	40	44	47	51	54	58	62	65	69	73	76				
BIAS	KPA	275	300	325	350	375	400	425	450	475	500	525				
37.5R39	LBS	35300	37500	39700	41900	44100*	46700	48100	50700	52000	55100	56800**				
	KG	16000	17000	18000	19000	20000*	21200	21800	23000	23600	25000	25750**				
40.5/75R39	LBS	39700	41900	45400	48100	49400*	52000	55100	56800	60000	61500	64000**				
	KG	18000	19000	20600	21800	22400*	23600	25000	25750	27250	28000	29000**				
BIAS	PSI	25	29	33	36	40	44	47	51	54	58					
	KPA	175	200	225	250	275	300	325	350	375	400					
37.5-51	LBS	37500	39700	43000	45400	48100	50700	53600(36)	55100	58400	60000(44)					
	KG	17000	18000	19500	20600	21800	23000	24300(36)	25000	26500	27250(44)					

Legend

▲ Permafoam inflation or special rim required

WIDE BASE SIZE

WIDE BASE SIZE

RADIAL



RM-4B+

RM-3A
RM-4A+

BIAS



American Miner SLHD

DIMENSIONAL DATA

Size	Type	Ind Code	Current In Line Location	Rim Width & Flange	INFLATED DIMENSIONS				LOADED DIMENSIONS				Revol Per mi km	Gross Contact Area in ² cm ²	Tire Volume gal ltrs		Tread Depth 1/32 in mm		PERFORMANCE CAPABILITY					
					Overall Width in mm		Overall Diameter in mm		Load Sect & Growth in mm		Static Load Rad in mm				2S tmph tkph	4S tmph tkph	6S tmph tkph							
53/80R63	RM-3A	E-3	N L E A	36.00-5.0	52.8	1341	149.3	3792	60.6	1539	66.2	1681	141.2	87.7	2230.0	14388	2025.0	7665.0	80	63.5	1200	1750	920	1345
	RM-4A+ #	E-4+	N L E A	36.00-5.0	52.8	1341	149.3	3792	60.6	1539	66.2	1681	141.2	87.7	2200.0	14194	1925.0	7287.0	132	104	1070#	1560#	820#	1195#
	RM-4B+ #	E-4+	N L E A	36.00-5.0	52.8	1341	149.3	3792	60.6	1539	66.2	1681	141.2	87.7	2200.0	14194	1915.0	7249.0	140	110	1016#	1480#	780#	1135#
59/80R63	RM-3A #	E-3	N L E A	44.00-5.0	58.9	1496	158.4	4023	68.1	1730	69.9	1775	133	82.6	2560.0	16516	2800.0	10599.0	89	70	1500#	2200#	1150#	1675#
	RM-4A+ #	E-4+	N L E A	44.00-5.0	58.9	1496	158.4	4023	68.1	1730	69.9	1775	133	82.6	2500.0	16129	2600.0	9842.0	146	116	1300#	1900#	995#	1450#
7.5-10NHS	American Miner SLHD	IND-3	N	5.5x10	8.2	208	25.0	635										25	19					

Sizes in bold type can be obtained in locations in bold. Extended lead time may be needed in other locations.

Legend	N = North America L = Latin America	E = Europe / Africa / Mid East A = Asia / Australia	# = Estimated Data * = Tube Type Tire	^ = Work Capability Factor
---------------	--	--	--	----------------------------

LOAD LIMITS AT COLD INFLATION PRESSURES

30 MPH (50 KM/H) MAXIMUM SPEED OFF-THE-ROAD HAULAGE SERVICE

RADIAL	PSI KPA	65 450	69 475	73 500	76 525	80 550	83 575	87 600	91 625	94 650	98 675	102 700
53/80R63	LBS	132500	135500	143500	147500	152000	156500	161000	165500	171000	176500	182000**
	KG	60000	61500	65000	67000	69000	71000	73000	75000	77500	80000	82500**
59/80R63	LBS	156500	165500	171000	176500	182000	187500	198500	204000	209500	215000	220500**
	KG	71000	75000	77500	80000	82500	85000	90000	92500	95000	97500	100000**

Legend ▲ Permafoam inflation or special rim required

WIDE BASE SIZE

65 SERIES SIZE

RADIAL



DIMENSIONAL DATA

Size	Type	Ind Code	Current In Line Location		Rim Width & Flange	INFLATED DIMENSIONS				LOADED DIMENSIONS				Revol Per mi km	Gross Contact Area		Tire Volume		Tread Depth		PERFORMANCE CAPABILITY						
						Overall Width		Overall Diameter		Load Sect & Growth		Static Load Rad			in ²	cm ²	gal	ltrs	1/32	mm	2S		4S		6S		
						in	mm	in	mm	in	mm	in	mm	mi	km					in	mm	tmph	tkph	tmph	tkph	tmph	tkph
22/65R25	AT-2A	L-3			14.00-1.5	21.5	546	54.5	1384	24.6	625	23.9	607	389	243	284.0	1848	110.1	416.6	27	22			^90	^130	^75	^110
25/55R25 (650/55R25)	GP-2A	L-2		E	17.00-2.0	24.6	625	54.2	1378	26.5	673	23.4	594	387	241	330.0	2130	121.4	459.8	34	27						
	GP-2B	L-3			17.00-2.0																						
25/65R25	RL-3F	E-3			19.50-2.0	25.5	647	58.5	1486	27.4	696	26.6	676	359	223	270.0	1740	161.4	611.0	40	32			125	180		
30/65R25 (750/65R25)	GP-3D	E-3T	N	E	24.00-3.0	30.3	769	64.1	1628	33.9	862	28.9	735	328	204	461.0	2976	225.0	852.0	47	37	162	240	120	180	78	110
	GP-3D	L-3T	N	E	24.00-3.0	30.3	769	64.1	1628	33.9	862	28.9	735	328	204	461.0	2976	225.0	852.0	47	37						
	RL-2+	E-3+T	N		24.00-3.0	30.2	767	64.1	1628	33.4	848	28.8	732	328	204	466.0	3004	219.9	833.1	54	43	155	230	115	170	75	110
	RL-2+	L-3+T	N		24.00-3.0	30.2	767	64.1	1628	34.0	864	28.4	721	328	204	450.0	2903	219.9	833.1	54	43						
550/65R25	GP-3D	L-3T			14.00-1.5	21.4	544	54.4	1382	23.9	607	24.3	617	386	240	290.0	1874	100.0	379.0	37	29						
555/65R25 (22/65R25)	AT-2A	E-3			14.00-1.5	21.5	546	54.5	1384	23.9	607	24.3	617	385	240	278.0	1794	110.1	416.6	27	22	195	280				
	AT-2A	L-3			14.00-1.5	21.5	546	54.5	1384	24.6	625	23.9	607	385	240	278.0	1793	110.1	416.6	27	22						

Sizes in bold type can be obtained in locations in bold.
Extended lead time may be needed in other locations.

Legend	N = North America	E = Europe / Africa / Mid East	# = Estimated Data	^ = Work Capability Factor
	L = Latin America	A = Asia / Australia	* = Tube Type Tire	

LOAD LIMITS AT COLD INFLATION PRESSURES

5 MPH (10 KM/H) MAXIMUM SPEED OFF-THE-ROAD SLOW SPEED SERVICE

RADIAL	PSI	58	62	65	69	73					
	KPA	400	425	450	475	500					
22/65R25	LBS	17100	17600	18200	19300	19800*					
(555/65R25)	KG	7750	8000	8250	8750	9000*					
555/65R25	LBS	17100	17600	18200	19300	19800*					
	KG	7750	8000	8250	8750	9000*					
RADIAL	PSI	58	62	65	69	73	76	80	83	87	91
	KPA	400	425	450	475	500	525	550	575	600	625
25/55R25	LBS	17600	18700	19300	20400*						
(650/55R25)	KG	8000	8500	8750	9250*						
25/65R25	LBS	19800	20400	21500	22700*	23400	24000	25400	26000	26800	27600**
	KG	9000	9500	9750	10300*	10600	10900	11500	11800	12150	12500**
30/65R25	LBS	30000	30900	33100	34200*	35300	36400	37500	38600	39700	41900**
	KG	13600	14000	15000	15500*	16000	16500	17000	17500	18000	19000**
550/65R25	LBS	16500	17600	18200	18700*	19800	20400	20900	22000	22700	23400**
	KG	7500	8000	8250	8500*	9000	9250	9500	10000	10300	10600**

30 MPH (50 KM/H) MAXIMUM SPEED OFF-THE-ROAD HAULAGE SERVICE

RADIAL	PSI	29	33	36	40	44	47	51	54
	KPA	200	225	250	275	300	325	350	375
22/65R25	LBS	6950	7600	8250	8800	9350	9900	10500	11000*
(555/65R25)	KG	3150	3450	3750	4000	4250	4500	4750	5000*
555/65R25	LBS	6950	7600	8250	8800	9350	9900	10500	11000*
	KG	3150	3450	3750	4000	4250	4500	4750	5000*

30 MPH (50 KM/H) MAXIMUM SPEED OFF-THE-ROAD ARTICULATED DUMP SERVICE

RADIAL	PSI	29	33	36	40	44	47	51	54	58	62
	KPA	200	225	250	275	300	325	350	375	400	425
25/65R25	LBS	8800	9650	10500	11000	12000	12800*	13600	13900	14800	15700**
	KG	4000	4375	4750	5000	5450	5800*	6150	6300	6700	7100**
30/65R25	LBS	13200	14300	15700	17100	18200	19300*	20400	21500	22700	23400**
	KG	6000	6500	7100	7750	8250	8750*	9250	9750	10000	10600**

Legend

▲ Permafoam inflation or special rim required

65 SERIES SIZE

DIMENSIONAL DATA

RADIAL

BIAS



GP-3D GP-2B RL-2+ TL-3A+ NRL D/L-5A

Size	Type	Ind Code	Current In Line Location		Rim Width & Flange	INFLATED DIMENSIONS				LOADED DIMENSIONS				Revol Per mi km	Gross Contact Area		Tire Volume		Tread Depth		PERFORMANCE CAPABILITY						
						Overall Width		Overall Diameter		Load Sect & Growth		Static Load Rad			in ²	cm ²	gal	ltrs	1/32 in	mm	2S		4S		6S		
						in	mm	in	mm	in	mm	in	mm	mi	km					in	mm	tmph	tkph	tmph	tkph	tmph	tkph
600/65R25	GP-3D	E-3T	N	E	17.00-2.0	23.4	594	56.9	1445	26.7	678	25.4	646	369	229	308.0	1984	128.0	485.4	42	33	132	190	99	140	66	100
	GP-3D	L-3T	N	E	17.00-2.0	23.4	594	56.9	1445	26.3	668	25.3	643	369	229	324.0	2087	128.0	485.4	42	33						
650/55R25 <i>(25/55R25)</i>	GP-2A	L-2		E	17.00-2.0	24.6	625	54.2	1378	26.5	673	23.4	594	387	241	330.0	2130	121.4	459.8	34	27						
	GP-2B	L-3			17.00-2.0																						
650/65R25	GP-3D	E-3T	N	E	19.5-2.5	26.3	668	58.7	1491	29.5	749	26.2	665	357	222	355.0	2290	150.0	568.0	44	35	144	210	108	160	73	110
	GP-3D	L-3T	N	E	19.5-2.5	26.3	668	58.7	1491	29.5	749	26.2	665	357	222	355.0	2290	150.0	568.0	44	35						
750/65R25 <i>(30/65R25)</i>	GP-3D	L-3T	N	E	24.00-3.0	30.3	769	64.1	1628	33.9	862	28.9	735	328	204	461.0	2976	225.0	852.0	47	37						
	RL-2+	L-3+T	N		24.00-3.0	30.2	767	64.1	1628	34.0	864	28.4	721	328	204	450.0	2903	219.9	833.1	54	43						
	TL-3A+	E-3+T	N	E	24.00-3.0	30.5	776	63.9	1622	34.5	875	28.0	711	328	205	450.0	2903	220.0	833.0	58	46	155	230	115	170	75	110
	TL-3A+	L-3+T	N	E	24.00-3.0	30.5	776	63.9	1622	33.5	851	28.1	714	328	205	450.0	2903	220.0	833.0	58	46	155	230	115	170	75	110
30/65-29	NRL D/L-5A	L-5			24.00-3.0	30.4	772	71.3	1811	33.1	841	32.6	828	289	180	436.0	2813	170.7	646.0	111	88			50	70	45	70

Sizes in bold type can be obtained in locations in bold. Extended lead time may be needed in other locations.

Legend	N = North America	E = Europe / Africa / Mid East	# = Estimated Data	^ = Work Capability Factor
	L = Latin America	A = Asia / Australia	* = Tube Type Tire	

LOAD LIMITS AT COLD INFLATION PRESSURES

5 MPH (10 KM/H) MAXIMUM SPEED OFF-THE-ROAD SLOW SPEED SERVICE

RADIAL	PSI	58	62	65	69	73	76	80	83	87	91
	KPA	400	425	450	475	500	525	550	575	600	625
600/65R25	LBS	19300	19800	20900	21500*	22700	23400	24000	24700	26000	26800**
	KG	8750	9000	9500	9750*	10300	10600	10900	11200	11800	12150**
650/65R25	LBS	22000	23400	24000	25400*	26000	26800	28300	29100	30000	30900**
	KG	10000	10600	10900	11500*	11800	12150	12850	13200	13600	14000**
750/65R25	LBS	30000	30900	33100	34200*	35300	36400	37500	38600	39700	41900**
	KG	13600	14000	15000	15500*	16000	16500	17000	17500	18000	19000**
RADIAL	PSI	58	62	65	69						
	KPA	400	425	450	475						
650/55R25	LBS	17600	18700	19300	20400*						
<i>(25/55R25)</i>	KG	8000	8500	8750	9250*						
BIAS	PSI	47	51	54	58						
	KPA	325	350	375	400						
30/65-29	LBS	28300	29100(20)	30900	32000(24)						
	KG	12850	13200(20)	14000	14500(24)						

30 MPH (50 KM/H) MAXIMUM SPEED OFF-THE-ROAD HAULAGE SERVICE

RADIAL	PSI	25	29	33	36	40	44	47
	KPA	175	200	225	250	275	300	325
650/55R25	LBS	7600	8550	9100	9900	10700	11400	12000*
<i>(25/55R25)</i>	KG	3450	3875	4125	4500	4875	5150	5450*

30 MPH (50 KM/H) MAXIMUM SPEED OFF-THE-ROAD ARTICULATED DUMP SERVICE

RADIAL	PSI	29	33	36	40	44	47	51	54	58	62
	KPA	200	225	250	275	300	325	350	375	400	425
650/65R25	LBS	9900	10700	11700	12300	13200	14300*	15200	15700	16500	17600**
	KG	4500	4875	5300	5600	6000	6500*	6900	7100	7500	8000**

30 MPH (50 KM/H) (50kph) MAXIMUM SPEED OFF-THE-ROAD HAULAGE SERVICE

RADIAL	PSI	29	33	36	40	44	47	51	54	58	62
	KPA	200	225	250	275	300	325	350	375	400	425
600/65R25	LBS	9100	9900	10700	11400	12300	13200*	13900	14300	15200	16100**
	KG	4125	4500	4875	5150	5600	6000*	6300	6500	6900	7300**
650/65R25	LBS	10500	11400	12300	13200	14300	15200*	16100	16500	17600	18200**
	KG	4750	5150	5600	6000	6500	6900*	7300	7500	8000	8250**
750/65R25	LBS	13600	14800	16100	17100	18700	19800*	20900	22000	22700	24000**
	KG	6150	6700	7300	7750	8500	9000*	9500	10000	10300	10900**

Legend

▲ Permafoam inflation or special rim required

65 SERIES SIZE

DIMENSIONAL DATA

RADIAL

BIAS



GP-4D RL-4D RL-4K Hi-Stability NDL D/L-5/15C NRL D/L-5A NRL D/L-4A NSM D/L-5B

Size	Type	Ind Code	Current In Line Location		Rim Width & Flange	INFLATED DIMENSIONS				LOADED DIMENSIONS				Gross Contact Area		Tire Volume		Tread Depth		PERFORMANCE CAPABILITY								
						Overall Width		Overall Diameter		Load Sect & Growth		Static Load Rad								Revol Per	mi	km	in ²	cm ²	gal	ltrs	in	mm
						in	mm	in	mm	in	mm	in	mm	mi	km					in	mm	mph	tkph	mph	tkph	mph	tkph	
775/65R29 <i>(800/65R29)</i>	GP-4D	E-4	N	E	24.00-3.0	31.2	792	68.9	1749	34.5	876	30.4	772	305	190	556.0	3585	250.0	946.0	67	53	169	250	125	180	105	150	
	GP-4D	L-4		E	24.00-3.0	31.2	792	68.9	1749	34.5	876	29.8	758	305	190	640.0	4130	250.0	946.0	67	53							
	GP-4D Hi-Stability	E-4	N	E	24.00-3.0	31.2	792	68.9	1749	34.5	876	30.4	772	305	190	556.0	3585	250.0	946.0	67	53	169	250	125	180	105	150	
	GP-4D Hi-Stability	L-4		E	24.00-3.0	31.2	792	68.9	1749	34.5	876	29.8	758	305	190	640.0	4130	250.0	946.0	67	53							
800/65R29	GP-4D	L-4			24.00-3.0	31.2	792	68.9	1749	34.5	876	29.8	758	305	190	640.0	4130	250.0	946.0	67	53							
875/65R29	GP-4D	E-4	N	L	E	A	27.00-3.0	33.9	861	74.0	1880	37.0	939	282	176	552.0	3561	325.0	1230.0	72	57	190	280	150	220	125	180	
	GP-4D	L-4	N		E		27.00-3.0	33.9	861	74.0	1880	37.0	939	282	176	676.0	4362	325.0	1230.0	72	57					^95	^140	
	GP-4D Hi-Stability	E-4	N	L	E	A	27.00-3.0	33.9	861	74.0	1880	37.0	939	282	176	552.0	3561	325.0	1230.0	72	57	190	280	150	220	125	180	
	GP-4D Hi-Stability	L-4	N		E		27.00-3.0	33.9	861	74.0	1880	37.0	939	282	176	676.0	4362	325.0	1230.0	72	57					^95	^140	
	RL-4D	L-4	N			27.00-3.0	33.9	860	74.0	1880	37.7	958	32.3	820	284	176	782.0	4698	323.0	1223.0	72	57					^95	^140
	RL-4K Hi-Stability	E-4	N	E		27.00-3.0	33.9	861	74.0	1880	38.1	968	32.7	831	309	192	676.0	4362	325.0	1230.0	72	57						
35/65-33	NDL D/L-5/15C	L-5	N			28.00-3.5	35.7	907	80.5	2045	38.7	983	36.7	932	253	157	652.0	4207	311.4	1178.7	122	96						
	NRL D/L-4A	E-4			28.00-3.5	35.7	907	80.5	2045									382.9	1449.4	74	59	115	170	95	140	75	110	
	NRL D/L-4A	L-4	N		A	28.00-3.5	35.7	907	80.5	2045	38.0	965	36.7	932	254	158	618.0	3987	382.9	1449.4	74	59	^90	^130	^75	^110	^60	^90
	NRL D/L-5A	L-5	N	L	A	28.00-3.5	35.5	901	80.2	2037	38.7	983	36.9	937	253	157	652.0	4207	311.4	1178.7	122	96			^65	^100	^60	^90
	NSM D/L-5B	L-5S	N			28.00-3.5	35.7	907	80.5	2045	38.7	983	36.7	932	253	157	652.0	4207	311.4	1178.7	122	96						

Sizes in bold type can be obtained in locations in bold. Extended lead time may be needed in other locations.

Legend	N = North America L = Latin America	E = Europe / Africa / Mid East A = Asia / Australia	# = Estimated Data * = Tube Type Tire	^ = Work Capability Factor
---------------	--	--	--	----------------------------

LOAD LIMITS AT COLD INFLATION PRESSURES

5 MPH (10 KM/H) MAXIMUM SPEED OFF-THE-ROAD SLOW SPEED SERVICE

	PSI	58	62	65	69	73	76	80	83	87	91				
RADIAL	KPA	400	425	450	475	500	525	550	575	600	625				
775/65R29	LBS	33100	34200	35300	37500*	38600	39700	40800	41900	44100	45400**				
(800/65R29)	KG	14500	15500	16000	17000*	17500	18000	18500	19000	20000	20600**				
800/65R29	LBS	33100	34200	35300	37500*	38600	39700	40800	41900	44100	45400**				
	KG	14500	15500	16000	17000*	17500	18000	18500	19000	20000	20600**				
RADIAL	PSI	69	73	76	80	83	87	91	94	98	102	105	109	112	116
	KPA	475	500	525	550	575	600	625	650	675	700	725	750	775	800
875/65R29	LBS	46700*	48100	49400	52000	53600	55100	56800**	58400	60000	61500	64000	66000	66000	68000***
	KG	21200*	21800	22400	23600	24300	25000	25750**	26500	27250	28000	29000	30000	30000	30750***
	PSI	47	51	54	58	62	65	69	73	76	80	83	87	91	
BIAS	KPA	325	350	375	400	425	450	475	500	525	550	575	600	625	
35/65-33	LBS	39700	41900(24)	43000	44100	46700	48100(30)	49400	50700	52000(36)	53600	55100	56800	58400(42)	
	KG	18000	19000(24)	19500	20000	21200	21800(30)	22400	23000	23600(36)	24300	25000	25750	26500(42)	

25 MPH (40 KM/H) 25MPH (40km/HR) Underground Haulage Service

	PSI	73	76	80	83	87	91	94	98	102	105	109	112	116
RADIAL	KPA	500	525	550	575	600	625	650	675	700	725	750	775	800
875/65R29	LBS	40800	41900	44100	45400	46700	48100	49400	50700	52000	53600	55100	56800	58400(****)
	KG	18500	19000	20000	20600	21200	21800	22400	23000	23600	24300	25000	25750	26500(****)

30 MPH (50 KM/H) MAXIMUM SPEED OFF-THE-ROAD HAULAGE SERVICE

	PSI	29	33	36	40	44	47	51	54	58	62
RADIAL	KPA	200	225	250	275	300	325	350	375	400	425
875/65R29	LBS	19300	20900	22700	24700	26000	27600*	29100	30900	33100	34200**
	KG	8750	9500	10300	11200	11800	12500*	13200	14000	15000	15500**

30 MPH (50 KM/H) MAXIMUM SPEED OFF-THE-ROAD ARTICULATED DUMP SERVICE

	PSI	29	33	36	40	44	47	51	54	58	62
RADIAL	KPA	200	225	250	275	300	325	350	375	400	425
800/65R29	LBS	16100	17600	18700	20400	21500	22700*	24000	25400	26800	28300**
(775/65R29)	KG	7300	8000	8500	9250	9750	10300*	10900	11500	12150	12850**

30 MPH (50 KM/H) 50KPH MAXIMUM SPEED OFF-THE-ROAD SERVICE

	PSI	29	33	36	40	44	47	51	54	58	62
RADIAL	KPA	200	225	250	275	300	325	350	375	400	425
775/65R29	LBS	15700	17100	18200	19800	20900	22000*	23400	24700	26000	27600**
(800/65R29)	KG	7100	7750	8250	9000	9500	10000*	10600	11200	11800	12500**

Legend

▲ Permafoam inflation or special rim required

65 SERIES SIZE

DIMENSIONAL DATA

RADIAL



Size	Type	Ind Code	Current In Line Location	Rim Width & Flange	INFLATED DIMENSIONS				LOADED DIMENSIONS				Revol Per mi km	Gross Contact Area in ² cm ²	Tire Volume gal ltrs	Tread Depth 1/32 in mm		PERFORMANCE CAPABILITY									
					Overall Width in mm	Overall Diameter in mm	Load Sect & Growth in mm	Static Load Rad in mm	2S tmph tkph	4S tmph tkph	6S tmph tkph																
35/65R33 (875/65R33)	RL-4K	L-4	N	28.00-3.5	35.6	904	81.9	2079	38.7	982	36.9	937	257	159	686.0	4426	425.0	1609.0	73	58							
	RL-4K 20/20	L-4		28.00-3.5	35.6	904	81.9	2079	38.7	982	36.9	937	257	159	686.0	4426	425.0	1609.0	73	58							
	RL-5K	L-5	N E A	28.00-3.5	35.6	904	81.9	2079	38.7	982	36.9	937	257	159	686.0	4426	411.0	1555.6	120	95							
	RL-5K (20/20)	L-5		28.00-3.5	35.6	904	81.9	2079	38.7	982	36.9	937	257	159	686.0	4426	411.0	1555.6	120	95							
	RL-5K 05/10	L-5		28.00-3.5	35.6	904	81.9	2079	38.7	982	36.9	937	257	159	686.0	4426	411.0	1555.6	120	95							
	RL-5S	L-5S		28.00-3.5	35.6	904	81.9	2079	38.7	982	36.9	937	257	159	686.0	4426	411.0	1555.6	120	95							
875/65R33 (35/65R33)	RL-3S	L-3S	N	28.00-3.5	35.9	912	82.1	2085	38.9	988	36.9	937	257	159.7	771.4	4977	425.0	1609.0	61	48.3							
	RL-4K (00/20)	L-4	N L E A	28.00-3.5	35.6	904	81.9	2079	38.7	982	36.9	937	257	159	686.0	4426	425.0	1609.0	73	58							
	RL-4K 20/20 #	L-4		28.00-3.5	35.6	904	81.9	2079	38.7	982	36.9	937	257	159	686.0	4426	425.0	1609.0	73	58							
	RL-4K Hi-Stability	L-4	N L E A	28.00-3.5	35.6	904	81.9	2079	38.7	982	36.9	937	257	159	686.0	4426	425.0	1609.0	73	58							
	RL-4K Hi-Stability 00/20	L-4	N L E A	28.00-3.5	35.6	904	81.9	2079	38.7	982	36.9	937	257	159	686.0	4426	425.0	1609.0	73	58							
	RL-4S	L-4S		E	28.00-3.5	35.6	904	81.9	2079	38.7	982	36.9	937	256	159	686.0	4426			72	57						
	RL-5K	L-5	N E A		28.00-3.5	35.6	904	81.9	2079	38.7	982	36.9	937	257	159	686.0	4426	411.0	1555.6	120	95						
	RL-5K (00/20)	L-5	N L E A		28.00-3.5	35.6	904	81.9	2079	38.7	982	36.9	937	257	159	686.0	4426	411.0	1555.6	120	95						
	RL-5K (20/20)	L-5			28.00-3.5	35.6	904	81.9	2079	38.7	982	36.9	937	257	159	686.0	4426	411.0	1555.6	120	95						
	RL-5K 05/10	L-5			28.00-3.5	35.6	904	81.9	2079	38.7	982	36.9	937	257	159	686.0	4426	411.0	1555.6	120	95						
	RL-5K Hi-Stability	L-5	N E A		28.00-3.5	35.6	904	81.9	2079	38.7	982	36.9	937	257	159	686.0	4426	411.0	1555.6	120	95						
	RL-5K Hi-Stability	L-5	N L E A		28.00-3.5	35.6	904	81.9	2079	38.7	982	36.9	937	257	159	686.0	4426	411.0	1555.6	120	95						
	RL-5S	L-5S	N E		28.00-3.5	35.6	904	81.9	2079	38.7	982	36.9	937	257	159	686.0	4426	411.0	1555.6	120	95						
	RT-4D Hi-Stability	E-4	N L E A		28.00-3.5	35.6	904	81.9	2080	38.6	980	36.9	937	265	164.7	816.3	5266	400.0	1514.0	81	64						
	RT-4D Hi-Stability	L-4	N L E A		28.00-3.5	35.6	904	81.9	2080	38.6	980	36.9	937	265	164.7	816.3	5266	400.0	1514.0	81	64						
RT-5D Hi-Stability	L-5	N L E A		28.00-3.5	35.6	904	81.9	2080	38.6	980	36.9	937	265	164.7	816.3	5266	350.0	1325.0	120	95.3							
1150/65R39 (45/65R39)	RL-4K	L-4	N	36.00-4.5	45.0	1143	101.6	2578	49.8	1264	44.9	1140	207	129	1046.0	6745	825.0	3123.0	89	71							
	RL-4K	L-4		36.00-4.5	45.0	1143	101.6	2578	49.8	1264	44.9	1140	207	129	1046.0	6745	825.0	3123.0	89	71							
	RL-4K	L-4		36.00-4.5	45.5	1156	101.6	2578	49.8	1264	44.9	1140	207	129	1046.0	6745	825.0	3123.0	89	71							
Sizes in bold type can be obtained in locations in bold. Extended lead times may be needed in other locations.																89 = Work Capability Factor											
Legend: N = North America, E = Europe / Africa / Middle East, A = Asia / Australia, L = Latin America																130 116 146 116											

LOAD LIMITS AT COLD INFLATION PRESSURES

5 MPH (10 KM/H) MAXIMUM SPEED OFF-THE-ROAD SLOW SPEED SERVICE

RADIAL	PSI	58	62	65	69	73	76	80	83	87	91	94	
	KPA	400	425	450	475	500	525	550	575	600	625	650	
35/65R33	LBS	43000	45400	46700	49400	50700*	52000	55100	56800	58400	60000	61500**	
(875/65R33)	KG	19500	20600	21200	22400	23000*	23600	25000	25750	26500	27250	28000**	
1150/65R39	LBS	74000	76000	80500	82500	88000*	91000	93500	96500	99000	102000	104500**	
	KG	33500	34500	36500	37500	40000*	41250	42500	43750	45000	46250	47500**	
RADIAL	PSI	73	76	80	83	87	91	94	98	102	105	109	116
	KPA	500	525	550	575	600	625	650	675	700	725	750	800
875/65R33	LBS	50700*	52000	55100	56800	58400	60000	61500**	64000	66000	68000	69500	71500***
(35/65R33)	KG	23000*	23600	25000	25750	26500	27250	28000**	29000	30000	30750	31500	32500***

25 MPH (40 KM/H) 25MPH (40km/HR) Underground Haulage Service

RADIAL	PSI	73	76	80	83	87	91	94	98	102	105	109	112	116
	KPA	500	525	550	575	600	625	650	675	700	725	750	775	800
875/65R33	LBS	44100	46700	48100	49400	50700	52000	53600	55100	56800	58400	60000	61500	64000(****)
(35/65R33)	KG	20000	21200	21800	22400	23000	23600	24300	25000	25750	25750	27250	28000	29000(****)

Legend

▲ Permafoam inflation or special rim required

65 SERIES SIZE

DIMENSIONAL DATA

RADIAL



RL-5K RL-5K 05/05 RL-5K (20/20) RL-4K
RL-4K 20/20

BIAS



NDL D/L-5/15C NRL D/L-4D NSM D/L-5B
NRL D/L-5A

Size	Type	Ind Code	Current In Line Location	Rim Width & Flange	INFLATED DIMENSIONS				LOADED DIMENSIONS				Revol Per mi km	Gross Contact Area in ² cm ²	Tire Volume gal ltrs	Tread Depth 1/32 in mm		PERFORMANCE CAPABILITY					
					Overall Width in mm	Overall Diameter in mm	Load Sect & Growth in mm	Static Load Rad in mm	mi km	in ² cm ²	gal ltrs	in mm				2S tmph tkph	4S tmph tkph	6S tmph tkph					
40/65-39	NRL D/L-5A	L-5	N A	32.00-4.0	42.4 1077	94.4 2398	45.9 1166	43.3 1100	216 134	927.0 5981	457.3 1731.0	137 109											
45/65R39 (1150/65R39)	RL-4K	L-4		36.00-4.5	45.0 1143	101.6 2578	49.8 1264	44.9 1140	207 129	1046.0 6745	825.0 3123.0	89 71											
	RL-5K (20/20)	L-5	N	36.00-4.5	45.5 1156	101.5 2577	51.9 1318	44.8 1139	213 132	1256.0 8106	750.0 2839.0	146 116											
1150/65R45 (45/65R45)	RL-4K	L-4		36.00-4.5	45.0 1143	107.8 2737	49.4 1255	48.0 1218	195 119	1195.0 7704	900.0 3407.0	89 71											
	RL-4K 20/20	L-4		36.00-4.5	45.0 1143	107.8 2737	49.4 1255	48.0 1218	195 119	1195.0 7704	900.0 3407.0	89 71											
	RL-5K	L-5	N	36.00-4.5	45.0 1143	107.8 2737	49.4 1255	48.0 1218	195 119	1195.0 7704	825.0 3123.0	149 118											
	RL-5K (20/20)	L-5		36.00-4.5	45.0 1143	107.8 2737	49.4 1255	48.0 1218	195 119	1195.0 7704	825.0 3123.0	149 118											
	RL-5K 05/05	L-5	N	36.00-4.5	45.0 1143	107.8 2737	49.4 1255	48.0 1218	195 119	1195.0 7704	825.0 3123.0	149 118											
45/65-45	NDL D/L-5/15C	L-5	N A	36.00-4.5	45.0 1143	107.6 2733	48.5 1232	49.4 1255	190 118	1050.0 6775	738.2 2794.3	148 117											
	NRL D/L-4D #	L-4	A	36.00-4.5	45.7 1161	107.6 2733	49.2 1250	47.9 1217	195 121	1138.0 7341		88 69.9											
	NRL D/L-5A #	L-5	N A	36.00-4.5	45.0 1143	107.6 2733	48.5 1232	49.4 1255	190 118	1050.0 6775	738.2 2794.3	145 115											
	NSM D/L-5B	L-5S	N A	36.00-4.5	45.0 1143	107.6 2733	48.5 1232	49.4 1255	190 118	1050.0 6775	738.2 2796.2	148 117											
45/65R45 (1150/65R45)	RL-4K	L-4		36.00-4.5	45.0 1143	107.8 2737	49.4 1255	48.0 1218	195 119	1195.0 7704	900.0 3407.0	89 71											
	RL-4K 20/20	L-4		36.00-4.5	45.0 1143	107.8 2737	49.4 1255	48.0 1218	195 119	1195.0 7704	900.0 3407.0	89 71											
	RL-5K	L-5		36.00-4.5	45.0 1143	107.8 2737	49.4 1255	48.0 1218	195 119	1195.0 7704	825.0 3123.0	149 118											
	RL-5K (20/20)	L-5		36.00-4.5	45.0 1143	107.8 2737	49.4 1255	48.0 1218	195 119	1195.0 7704	825.0 3123.0	149 118											
	RL-5K 05/05	L-5		36.00-4.5	45.0 1143	107.8 2737	49.4 1255	48.0 1218	195 119	1195.0 7704	825.0 3123.0	149 118											
50/65-51	NRL D/L-5A	L-5		40.00-4.5	51.4 1306	120.5 3061	56.0 1422	54.6 1387	171 106	1630.0 10514	846.0 3202.1	160 127											

Sizes in bold type can be obtained in locations in bold. Extended lead time may be needed in other locations.

Legend	N = North America L = Latin America	E = Europe / Africa / Mid East A = Asia / Australia	# = Estimated Data * = Tube Type Tire	^ = Work Capability Factor
---------------	--	--	--	----------------------------

LOAD LIMITS AT COLD INFLATION PRESSURES

5 MPH (10 KM/H) MAXIMUM SPEED OFF-THE-ROAD SLOW SPEED SERVICE

BIAS	PSI	47	51	54	58	62	65	69	73							
	KPA	325	350	375	400	425	450	475	500							
40/65-39	LBS	52000	55100	56800	60000(30)	61500	64000	66000	68000(36)							
	KG	23600	25000	25750	27250(30)	28000	29000	30000	30750(36)							
RADIAL	PSI	58	62	65	69	73	76	80	83	87	91	94				
	KPA	400	425	450	475	500	525	550	575	600	625	650				
45/65R39 <i>(1150/65R39)</i>	LBS	74000	76000	80500	82500	88000*	91000	93500	96500	99000	102000	104500**				
	KG	33500	34500	36500	37500	40000*	41250	42500	43750	45000	46250	47500**				
1150/65R45	LBS	78500	82500	85500	88000	93500*	96500	99000	102000	104500	110000	113500**				
	KG	35500	37500	38750	40000	42500*	43750	45000	46500	47500	50000	51500**				
45/65R45	LBS	78500	82500	85500	88000	93500*	96500	99000	102000	104500	110000	113500**				
	KG	35500	37500	38750	40000	42500*	43750	45000	46250	47500	50000	51500**				
BIAS	PSI	47	51	54	58	62	65	69	73	76	80	83	87	91	94	98
	KPA	325	350	375	400	425	450	475	500	525	550	575	600	625	650	675
45/65-45	LBS	71500	76000	78500	82500	85500(38)	88000	91000	93500	96500(46)	99000	102000	104500	104500	107500	110000(58)
	KG	32500	34500	35500	37500	38750(38)	40000	41250	42500	43750(46)	45000	46250	47500	47500	48750	50000(58)
BIAS	PSI	47	51	54	58	62	65	69	73	76	80	83	87	91	94	
	KPA	325	350	375	400	425	450	475	500	525	550	575	600	625	650	
50/65-51	LBS	93500	96500	102000	104500	107500	113500	117000(46)	120000	123500	128000	128000(54)	132500	135500	139000(62)	
	KG	42500	43750	46250	47500	48750	51500	53000(46)	54500	56000	58000	58000(54)	60000	61500	63000(62)	

Legend

▲ Permafoam inflation or special rim required

METRIC SIZE - HIGH SPEED

DIMENSIONAL DATA

RADIAL



AS-3A AT-2A GP-2B MC-1A

Size	Type	Ind Code	Current In Line Location	Rim Width & Flange	Min. Dual Spacing in mm	INFLATED DIMENSIONS				LOADED DIMENSIONS				Revol Per mi km		Gross Contact Area in ² cm ²		Tire Volume gal ltrs		Tread Depth 1/32 in mm		PERFORMANCE CAPABILITY		
						Overall Width in mm	Overall Diameter in mm	Load Sect & Growth in mm	Static Load Rad in mm	2S tmph tkph	4S tmph tkph	6S tmph tkph												
445/90R21	AT-2A	E-3		10.00-1.5	20.2 513	17.1 434	52.1 1323	18.8 478	23.6 599	403 250	178.0 1148	8.0 303.0	33 26											
385/95R24	GP-2B	E-3		10.00W	17.7 450	15.2 386	53.5 1359	15.5 394	24.9 632	392 244	152.0 981		30 24											
	MC-1A	E-1		10.00W	17.7 450	14.7 373	53.5 1359	16.0 406	24.7 627	393 244	123.0 794	75.0 284.0	31 24											
385/95R25	AS-3A	E-3		10.00-1.5	17.7 450	15.0 381	53.5 1359	16.4 416	23.9 608	393 244	152.0 982	33.0 125.0	32 25											
	GP-2B	E-3	N E	10.00-1.5	17.7 450	15.2 386	53.5 1359	15.5 394	24.9 632	392 244	152.0 982		30 24											
	MC-1A	E-1		10.00-1.5	17.7 450	14.3 363	53.7 1394	15.6 396	24.0 610	391 243	123.0 793	68.7 260.1	31 25											
395/80R25	GP-2B	E-3	E	12.00-1.3		15.6 396	50.3 1278	17.2 436	22.8 580	419 260	198.0 1277		30 24											
445/80R25	GP-2B	E-3	E	14.00-1.5		17.4 442	53.2 1351	19.1 485	24.6 625	395 245	178.0 1148	87.6 331.6	32 25											
445/95R25	GP-2B	E-3	N E A	11.25-2.0	20.2 513	17.2 438	58.6 1489	19.0 482	27.3 693	358 223	194.0 1251	96.2 364.3	34 27											
	MC-1A	E-1		11.25-2.0		16.9 429	59.0 1499	18.6 472	27.2 691	356 221	197.0 1271	101.7 385.0	31 25											
525/80R25	GP-2B	E-3	N	17.00-2.0		20.9 531	58.1 1476	23.1 586	26.7 678	362 224	238.0 1534	132.4 501.3	36 28											
555/65R25	AT-2A	E-3		14.00-1.5		21.5 546	54.5 1384	23.9 607	24.3 617	385 240	278.0 1794	110.1 416.6	27 22	195 280										
605/80R25	GP-2B	E-3		19.5-2.5		24.1 612	63.3 1608	26.8 680	29.4 746	332 206	265.0 1710	192.6 728.0	39 31											

Sizes in bold type can be obtained in locations in bold.
Extended lead time may be needed in other locations.

Legend	N = North America	E = Europe / Africa / Mid East	# = Estimated Data	^ = Work Capability Factor
	L = Latin America	A = Asia / Australia	* = Tube Type Tire	

LOAD LIMITS AT COLD INFLATION PRESSURES

45 MPH (70 KM/H) MAXIMUM SPEED SERVICE

RADIAL	PSI	105	109	116	131	141				
	KPA	725	750	800	900	975				
385/95R24	LBS	11700	12000	12300(L)	13270(M)	13930(N)				
	KG	5300	5450	5600(L)	6000(M)	6300(N)				
385/95R25	LBS	11700	12000	12300(L)	13270(M)	13930(N)				
	KG	5300	5450	5600(L)	6000(M)	6300(N)				
RADIAL	PSI	76	80	83	87	91	94	98	102	
	KPA	525	550	575	600	625	650	675	700	
445/80R25	LBS	10500	11000	11400	11700	12000	12300	12800	13200(170E)	
	KG	4750	5000	5180	5300	5400	5600	5800	6000(170E)	
525/80R25	LBS	13600	14300	14800	15200	15700	16100	16500	17100(179E)	
	KG	6150	6500	6700	6900	7100	7300	7500	7750(179E)	
605/80R25	LBS	17600	18200	18700	19300	20400	20900	21500	22000(188E)	
	KG	8000	8250	8500	8750	9250	9500	9750	10000(188E)	
RADIAL	PSI	105	109	112	116	120	123	127	131	
	KPA	725	750	775	800	825	850	875	900	
445/95R25	LBS	13600	13900	14300	14800	14800	15200	15700	16100(177E)	
	KG	6150	6300	6500	6700	6900	7100	7300	7300(177E)	
RADIAL	PSI	65	69	73	76	80	83	87	91	94
	KPA	450	475	500	525	550	575	600	625	650
555/65R25 (22/65R25)	LBS	10700	11000	11700	12000	12300	12800	13200	13600	13900(172E)
	KG	4875	5000	5300	5450	5600	5800	6000	6150	6300(172E)

55 MPH (90 KM/H) MAXIMUM SPEED SERVICE

RADIAL	PSI	65	70	75	80	85	90	95	100	105	110				
	KPA	450	480	520	550	590	620	660	690	720	760				
445/90R21 (16.00R21)	LBS	9990	10560	11110	11650	12160	12660	13150	13900(L)	14350	14800(M)				
	KG	4530	4790	5040	5280	5520	5740	5960	6300(L)	6500	6700(M)				
RADIAL	PSI	65	70	75	80	85	90	95	100	105	110	115	131	141	
	KPA	450	475	525	550	575	625	650	700	725	750	800	900	975	
385/95R24	LBS	8150	8620	9070	9500	9930	10340	10730	11400(J)	11700	12000	12300(L)	13270(M)	13930(N)	
	KG	3700	3910	4110	4310	4500	4690	4870	5150(J)	5300	5450	5600(L)	6000(M)	6300(N)	
385/95R25	LBS	8150	8620	9070	9500	9930	10340	10730	11400(J)	11700	12000	12300(L)	13270(M)	13930(N)	
	KG	3700	3910	4110	4310	4500	4690	4870	5150(J)	5300	5450	5600(L)	6000(M)	6300(N)	
RADIAL	PSI	110													
	KPA	750													
445/95R25	LBS	16100(177E)													
	KG	7300(177E)													

Legend ▲ Permafoam inflation or special rim required

METRIC SIZE

MINE SERVICE

DIMENSIONAL DATA

RADIAL



RL-5K (24/24)RL-5K (12/12)

BIAS



UMS-3B XTR-3B Xtra Traction Grip Xtra Traction WL Traction Mine Svc

Size	Type	Ind Code	Current In Line Location	Rim Width & Flange	INFLATED DIMENSIONS				LOADED DIMENSIONS				Revol Per		Gross Contact Area		Tread Depth	
					Overall Width in	mm	Overall Diameter in	mm	Load Sect & Growth in	mm	Static Load Rad in	mm						
15L-10NHS	* UMS-3B			13.00B	14.4	366	27.7	704	15.1	384	12.8	325	747	464	80.0	516	27	21
27X15-10NHS	* UMS-3B		N	13.00B	14.4	366	27.7	704	15.1	384	12.8	325	747	464	80.0	516	27	21
27X9-10NHS	* UMS-3B		N	6.00SP	9.5	241	26.7	678									25	20
24X12-12NHS	XTR-3B		N	9	11.8	300	24.8	630	12.4	315	11.3	287	838	521	50.0	323	23	18
10.00L-15NHS (36X11-15)	* Traction Mine Svc			7.50V	11.0	279	36.5	927	12.3	312	16.7	424	569	354	94.0	606	27	21
	* Xtra Traction WL			7.50V	11.2	284	36.1	917	12.5	318	16.6	422	574	357	91.0	587	27	21
14.50L-15NHS (35X15-15)	* Traction Mine Svc			11.5	14.2	361	35.2	894	15.5	394	16.4	417	586	364	120.0	774	31	25
	Xtra Traction WL			11.5	14.2	361	35.4	899	15.5	394	16.4	417	586	364	120.0	774	31	25
32X12-15NHS	* Xtra Traction Grip			9.75BD	12.1	307	32.3	820	13.3	338	15.1	384	638	396	80.0	516	26	21
32X14.50-15NHS (32X15-15)	* Traction Mine Svc			11.5	14.2	361	32.8	833	14.6	371	15.1	384	632	393	86.0	555	31	25
	Xtra Traction WL			11.5	14.2	361	33.1	841	14.6	371	15.1	384	632	393	86.0	555	31	25
32X15-15NHS (32X14.50-15)	* Traction Mine Svc		N	11.5	14.2	361	32.8	833	14.6	371	15.1	384	632	393	86.0	555	31	25
	Xtra Traction WL		N	11.5	14.2	361	33.1	841	14.6	371	15.1	384	632	393	86.0	555	31	25
35X15-15NHS (14.50L-15)	* Traction Mine Svc			11.5	14.2	361	35.2	894	15.5	394	16.4	417	586	364	120.0	774	31	25
	Xtra Traction WL			11.5	14.2	361	35.4	899	15.5	394	16.4	417	586	364	120.0	774	31	25
35X15R15NHS	RL-5K (12/12)	L-5		11.5	14.4	366	34.9	886	15.7	398	15.4	391	611	379	87.0	559	60	48
	RL-5K (24/24)	L-5		11.5	14.4	366	34.9	886	15.7	398	15.4	391	611	379	87.0	559	60	48

Sizes in bold type can be obtained in locations in bold. Extended lead time may be needed in other locations.

Legend	N = North America L = Latin America	E = Europe / Africa / Mid East A = Asia / Australia	# = Estimated Data * = Tube Type Tire	^ = Work Capability Factor
---------------	--	--	--	----------------------------

LOAD LIMITS AT COLD INFLATION PRESSURES

5 MPH (10 KM/H) OFF-THE-ROAD UNDERGROUND MINE SERVICE

BIAS	PSI	95	100	105	110	115	120	125	130	135	140	145	150	▲
	KPA	660	690	720	760	790	830	860	900	930	970	1000	1030	
15L-10NHS	LBS	6515	6715	6905	7100	7285	7470	7650(20)	7825	8000	8175	8345	8510(24)	
(27X15-10)	KG	2955	3045	3130	3220	3305	3390	3470(20)	3550	3630	3710	3785	3860(24)	
27X15-10NHS	LBS	6515	6715	6905	7100	7285	7470	7650(20)	7825	8000	8175	8345	8510(24)	
	KG	2955	3045	3130	3220	3305	3390	3470(20)	3550	3630	3710	3785	3860(24)	
27X9-10NHS	LBS	4405	4540(12)	4675	4800	4930	5050	5175	5295	5415(16)				
	KG	2000	2060(12)	2120	2175	2235	2290	2345	2400	2455(16)				
24X12-12NHS	LBS	5260	5420	5580	5740	5900	6050	6200	6350	6450	6600	6750	6900	7900(24)
	KG	2385	2460	2530	2605	2675	2745	2810	2880	2925	2995	3060	3130	3585(24)
32X12-15NHS	LBS	7150	7400	7600	7800	8000	8200	8400	8600	8800	9000	9150(20)	9350(24)	
	KG	3245	3355	3445	3540	3630	3720	3810	3900	3990	4080	4150(20)	4240(24)	
32X14.50-15NHS	LBS	8350	8600	8850	9100	9300	9550	9800	10000(20)	10200	10500	10700	10900	11100(24)
	KG	3790	3900	4015	4130	4220	4330	4445	4535(20)	4625	4765	4855	4945	5035(24)
32X15-15NHS	LBS	8350	8600	8850	9100	9300	9550	9800	10000(20)	10200	10500	10700	10900	11100(24)
	KG	3790	3900	4015	4130	4220	4330	4445	4535(20)	4625	4765	4855	4945	5035(24)
BIAS	PSI	95	100	105	110	115	120	125	130	135	140	145	▲	
	KPA	660	690	720	760	790	830	860	900	930	970	1000		
10.00L-15NHS	LBS	7520	7750	7975	8195	8410(16)	8620	8830	9035	9235	9435	9630(20)	10750(24)▲	
(36X11-15)	KG	3410	3515	3615	3715	3815(16)	3910	4005	4100	4190	4280	4370(20)	4875(24)▲	
BIAS	PSI	95	100	105	110	115	120	125	130	135	140	145	150	▲
	KPA	660	690	720	760	790	830	860	900	930	970	1000	1030	▲
14.50L-15NHS	LBS	9415	9705	9985	10260	10530	10795	11055	11310(20)	11565	11815	12060	12300	13905(28)▲
(35X15-15)	KG	4270	4400	4530	4655	4775	4895	5015	5130(20)	5245	5360	5470	5580	6305(28)▲
35X15-15NHS	LBS	9415	9705	9985	10260	10530	10795	11055	11310(20)	11565	11815	12060	12300	13905(28)
	KG	4270	4400	4530	4655	4775	4895	5015	5130(20)	5245	5360	5470	5580	6305(28)
RADIAL	PSI	105	109	112	116	120	123	127	131	134	138	141	145	▲
	KPA	725	750	775	800	825	850	875	900	925	950	975	1000	1025
35X15R15NHS	LBS	10200	10500	10700	11000	11400	11700	12000	12000	12300	12800	12800	13200	13200
	KG	4625	4750	4875	5000	5150	5300	5450	5450	5600	5800	5800	6000	8300

Legend ▲ Permafoam inflation or special rim required

MINE SERVICE

DIMENSIONAL DATA

RADIAL

BIAS



RL-5K (24/24)RL-5K (08/08)RL-5K (12/12) RL-5S RL-5K (00/24) Rock Mine Service SMO-5B XTR-3B HR Lug UMS-3A Xtra Traction WL Traction Mine Svc WRL-3A

Size	Type	Ind Code	Current In Line Location	Rim Width & Flange	INFLATED DIMENSIONS		LOADED DIMENSIONS		Revol Per	Gross Contact Area		Tread Depth						
					Overall Width in	Overall Diameter in	Load Sect & Growth in	Static Load Rad in		in ²	cm ²	1/32 in	mm					
36X11-15NHS <i>(10.00L-15)</i>	Traction Mine Svc			7.50V	11.0	279	36.5	927	12.3	312	16.7	424	569	354	94.0	606	27	21
	Xtra Traction WL			7.50V	11.2	284	36.1	917	12.5	318	16.6	422	574	357	91.0	587	27	21
36X11R15NHS	RL-5K (12/12)	L-5		7.5	10.8	274	36.3	922	11.5	291	16.0	405	587	365	58.0	373	60	48
	RL-5K (24/24)	L-5		7.5	10.8	274	36.3	922	11.5	291	16.0	405	587	365	58.0	373	60	48
38X16-15NHS	Rock Mine Service			11.5	15.3	389	38.7	983	16.2	411	17.8	452	531	330	145.0	935	27	21
	XTR-3D			11.5	15.3	389	38.4	975	16.2	411	17.8	452	531	330	145.0	935	29	23
8.25-15NHS	Traction Mine Svc			6.50T	10.2	259	34.0	864	11.4	290	15.8	401	607	377	76.0	490	27	21
	Xtra Traction WL			6.50T	10.2	259	34.0	864	11.4	290	15.8	401	607	377	76.0	490	27	21
10.00-20NHS	HR Lug		N	7.5	10.9	277	42.2	1072	11.8	300	19.9	506	498	309	74.0	477	27	21
12.00-20NHS	SMO-5B	L-5S	E	8.5	13.2	335	46.3	1176									80	64
	UMS-3A		N	8.5	13.0	330	45.6	1158	14.4	366	20.8	528	457	284	125.0	807	28	22
12.00R20NHS	RL-5K	L-5		8.5	12.3	312	47.2	1199	13.7	348	20.8	528	451	280	165.0	1067	78	62
	RL-5K (00/24)	L-5	N	8.5	12.3	312	46.6	1184	13.7	348	20.8	528	451	280	165.0	1067	78	62
	RL-5K (08/08)	L-5	N	8.5	12.3	312	46.6	1184	13.7	348	20.8	528	451	280	165.0	1067	78	62
	RL-5K (12/12)	L-5	N	8.5	12.3	312	46.6	1184	13.7	348	20.8	528	451	280	165.0	1067	78	62
	RL-5K (24/24)	L-5	N	8.5	12.3	312	46.6	1184	13.7	348	20.8	528	451	280	165.0	1067	78	62
	RL-5S	L-5S	N	8.5	12.3	312	46.6	1184	13.7	348	20.8	528	451	280	165.0	1067	78	62
14.00-20NHS	UMS-3A		N	10.00W	14.8	376	49.0	1245	16.1	409	22.4	569	425	264	150.0	968	33	26
	WRL-3A	E-3	N A	10.00W	14.8	376	49.1	1247	16.1	409	22.8	579	417	259	150.0	968	34	27
	XTR-3B		N	10.00W	15.8	401	49.2	1250									32	25

Sizes in bold type can be obtained in locations in bold. Extended lead time may be needed in other locations.

Legend	N = North America L = Latin America	E = Europe / Africa / Mid East A = Asia / Australia	# = Estimated Data * = Tube Type Tire	^ = Work Capability Factor
---------------	--	--	--	----------------------------

LOAD LIMITS AT COLD INFLATION PRESSURES

5 MPH (10 KM/H) OFF-THE-ROAD UNDERGROUND MINE SERVICE

		95	100	105	110	115	120	125	130	135	140	145	▲				
BIAS	PSI	660	690	720	760	790	830	860	900	930	970	1000					
	KPA	660	690	720	760	790	830	860	900	930	970	1000					
36X11-15NHS	LBS	7520	7750	7975	8195	8410(16)	8620	8830	9035	9235	9435	9630(20)	10750(24)▲				
(10.00L-15)	KG	3410	3515	3615	3715	3815(16)	3910	4005	4100	4190	4280	4370(20)	4875(24)▲				
	PSI	105	109	112	116	120	123	127	131	134	138	141	145	149	▲		
RADIAL	KPA	725	750	775	800	825	850	875	900	925	950	975	1000	1025			
36X11R15NHS	LBS	8250	8550	8550	8800	9100	9350	9350	9650	9900	10200	10200	10500	10700	12500		
	KG	3750	3875	3875	4000	4125	4250	4250	4375	4500	4625	4625	4750	4875	5675		
12.00R20NHS	LBS	12300	12800	12800	13200	13600**	13900	13900	14300	14800	15200***	15200	15700	16100	20000		
	KG	5600	5800	5800	6000	6150**	6300	6300	6500	6700	6900***	6900	7100	7300	9075		
	PSI	95	100	105	110	115	120	125	130	135	140	145	150	▲	▲	▲	
BIAS	KPA	660	690	720	760	790	830	860	900	930	970	1000	1030				
38X16-15NHS	LBS	11500	11810	12150	12485	12815	13140	13455	13770	14075	14380	14675	14970	15830(28)	17200(32)	19500(40)	
	KG	5215	5355	5510	5665	5810	5960	6105	6245	6385	6520	6655	6790	7180(28)	7800(32)	8845(40)	
	PSI	95	100	105	110	115	120	125	130	135	140	▲					
BIAS	KPA	660	690	720	760	790	830	860	900	930	970						
8.25-15NHS	LBS	5605	5775	5940	6105	6265	6425	6580	6730	6880	7030(16)	8910(24)▲					
	KG	2540	2620	2695	2770	2840	2915	2985	3055	3120	3190(16)	4040(24)▲					
	PSI	95	100	105	110												
BIAS	KPA	660	690	720	760												
10.00-20NHS	LBS	9350(14)	9650	9900	10200(16)												
	KG	4250(14)	4375	4500	4625(16)												
	PSI	95	100	105	110	115	120	125	130	135	140	145	150	▲			
BIAS	KPA	660	690	720	760	790	830	860	900	930	970	1000	1030				
12.00-20NHS	LBS	11700	12000(16)	12300	12800	13200	13600(20)	13900	13900	14300	14800	15200(24)	15200	16500(28)			
	KG	5300	5450(16)	5600	5800	6000	6150(20)	6300	6500	6500	6700	6900(24)	6900	7500(28)			
	PSI	95	100	105	110	115	120	125	130	135	140	▲	▲				
BIAS	KPA	660	690	720	760	790	830	860	900	930	970						
14.00-20NHS	LBS	16100	16600(20)	17100	17600	18200	18700(24)	18700	19300	19800	20400(28)	22000(32)▲	28300(48)▲				
	KG	7300	7500(20)	7750	8000	8250	8500(24)	8500	8750	9000	9250(28)	10000(32)▲	12850(48)▲				

Legend ▲ Permafoam inflation or special rim required

MINE SERVICE

DIMENSIONAL DATA

RADIAL

BIAS



RL-4J RL-5K (24/24) AMS-4/5A Rock Mine Service SMO-5B UMS-3A XTR-3C Xtra Traction WL
 RL-5K SMO-5B/C

Size	Type	Ind Code	Current In Line Location	Rim Width & Flange	INFLATED DIMENSIONS		LOADED DIMENSIONS		Revol Per	Gross Contact Area		Tread Depth						
					Overall Width in mm	Overall Diameter in mm	Load Sect & Growth in mm	Static Load Rad in mm		in ²	cm ²	1/32 in	mm					
42X13-20NHS	* Xtra Traction WL			9.5	12.9	328	41.7	1059	13.8	351	19.7	500	493	306	85.0	548	27	21
44X18-20NHS	Xtra Traction WL			15.00T	18.5	470	44.3	1125	19.6	498	20.3	516	470	292	200.0	1290	44	35
46X12R20NHS	RL-5K (24/24) #	L-5	N	8.50-2.0	12.3	312	46.6	1184	13.7	348	20.8	528	451	280	165.0	1067	78	62
46X15R20NHS	RL-5K #	L-5	N	11.00-2.0	14.8	376	46.6	1184	16.2	411	20.8	529	451	280	198.0	1277	78	62
46X18R20NHS	RL-5K (24/24) #	L-5	N	13.00-2.0	16.8	427	46.6	1184	18.2	462	20.8	528	451	280	240.0	1548	78	62
50X20-20NHS	Rock Mine Service			15.00T	19.5	495	49.4	1255	21.1	541	22.7	577	417	259	230.0	1484	33	26
	XTR-3C		N	15.00T	20.2	513	50.2	1275			23.0	584	421	262	275.0	1774	32	25
9.50-20NHS	* SMO-5B	L-5S	L A	7.5	11.2	283	41.4	1052	12.2	310	19.1	485	498	309	105.0	677	72	57
12.00-24NHS	* AMS-4/5A	L-4		8.50V	13.1	333	50.7	1288	14.8	376	23.6	599	402	250	121.0	781	55	43
	SMO-5B	L-5S		8.5	12.8	325	50.2	1275	14.8	376	23.6	599	402	250	121.0	781	83	66
	SMO-5B	L-5S	N L E	8.5	12.8	325	50.2	1275	14.8	376	23.6	599	402	250	121.0	781	83	66
	* SMO-5B/C	L-5S	N L E	8.50V	12.8	325	50.2	1275	14.8	376	23.6	599	402	250	121.0	781	83	66
	* UMS-3A		N E A	8.50V	12.8	325	49.5	1257	14.0	356	22.9	582	433	269	140.0	903	28	22
12.00R24NHS	* RL-4J	E-4		8.5	13.3	338	50.3	1275	14.5	368	23.5	599	420	261	113.0	729	42	33

Sizes in bold type can be obtained in locations in bold. Extended lead time may be needed in other locations.

Legend	N = North America L = Latin America	E = Europe / Africa / Mid East A = Asia / Australia	# = Estimated Data * = Tube Type Tire	^ = Work Capability Factor
---------------	--	--	--	----------------------------

LOAD LIMITS AT COLD INFLATION PRESSURES

5 MPH (10 KM/H) OFF-THE-ROAD UNDERGROUND MINE SERVICE

BIAS	PSI	95	100	105	110	115	120	125	130	135	140	145	150	▲	▲	
	KPA	660	690	720	760	790	830	860	900	930	970	1000	1030			
42X13-20NHS	LBS	10500	10800	11100(16)	11500	11800	12100	12300	12600	12900(20)	13200	13500	13700	17000(32)	21600(48)	
	KG	4765	4900	5035(16)	5215	5350	5490	5580	5715	5850(20)	5985	6125	6215	7710(32)	9800(48)	
BIAS	PSI	95	100	105	110	115	120	125	130	135	140	145	150	▲	▲	▲
	KPA	660	690	720	760	790	830	860	900	930	970	1000	1030			
44X18-20NHS	LBS	14300	14700	15200	15600	16000	16400	16800	17200	17600	17900	18300	18700	20100(32)	21500(36)	25500(48)
	KG	6485	6670	6895	7075	7260	7440	7620	7800	7985	8120	8300	8480	9115(32)	9750(36)	11565(48)
RADIAL	PSI	105	109	112	116	120	123	127	131	134	138	141	145	149	▲	
	KPA	725	750	775	800	825	850	875	900	925	950	975	1000	1025		
46X12R20NHS <i>(12.00R20)</i>	LBS	12300	12800	12800	13200	13600**	13900	13900	14300	14800	15200***	15200	15700	16100	24100▲	
	KG	5600	5800	5800	6000	6150**	6300	6300	6500	6700	6900***	6900	7100	7300	10930▲	
46X15R20NHS	LBS	15200	15700	16100	16100***	16500	17100	17600	17600	18200	18700	18700	19300	19800	29700	
	KG	6900	7100	7300	7300***	7500	7750	8000	8000	8250	8500	8500	8750	9000	13500	
46X18R20NHS	LBS	16100	16500	16500	17100***	17600	18200	18200	18700	19300	19800	19800	20400	20900	31700	
	KG	7300	7500	7500	7750***	8000	8250	8250	8500	8750	9000	9000	9250	9500	14400	
BIAS	PSI	95	100	105	110	115	120	125	130	135	▲					
	KPA	660	690	720	760	790	830	860	900	930						
50X20-20NHS	LBS	22500	23200	23900	24500	25200	25800(28)	26400	27100	27700(32)	30000(36)▲					
	KG	10200	10500	10800	11100	11400	11700(28)	12000	12300	12600(32)	13610(36)▲					
BIAS	PSI	69	73	76	80	83	87	91	94	98	102	105	109	112	116	120
	KPA	475	500	525	550	575	600	625	650	675	700	725	750	775	800	825
12.00-24NHS	LBS	11000	11400	11700	12000	12300	12300	12800	13200	13600(16)	13600	13900	14300▲	14800▲	14800▲	15200(20)▲
	KG	5000	5150	5300	5450	5600	5600	5800	6000	6150(16)	6150	6300	6500▲	6700▲	6700▲	6900(20)▲

Legend ▲ Permafoam inflation or special rim required

MINE SERVICE

DIMENSIONAL DATA

RADIAL



RL-4J RL-5K (24/24) RL-5K (08/08) RL-5K (12/12)

BIAS



AMS-4/5A SMO-5B/C SMO-5B UMS-3A WRL-3A
SMO D/L-5C SMO D/L-5B

Size	Type	Ind Code	Current In Line Location	Rim Width & Flange	INFLATED DIMENSIONS				LOADED DIMENSIONS				Revol Per		Gross Contact Area		Tread Depth	
					Overall Width		Overall Diameter		Load Sect & Growth		Static Load Rad		mi	km	in ²	cm ²	1/32 in	mm
14.00-24NHS	SMO-5B	L-5S		10.00W	15.3	389	55.6	1412	17.0	432	25.9	658	367	228	177.0	1142	96	76
	SMO-5B SA	L-5S		10.00W	14.3	363	53.4	1356	15.9	404	25.2	640	384.9	239.1	194.0	1252	82	65.2
	* SMO-5B/C	L-5S	L E A	10.00W	15.3	389	55.6	1412	17.0	432	25.4	645	373	232	177.0	1142	96	76
	* UMS-3A		N	10.00W	14.6	371	52.7	1339	16.2	411	24.6	625	387	241	175.0	1125	33	26
	WRL-3A	E-3	N	10.00VA	14.6	371	52.7	1339	16.2	411	24.6	625	387	241	175.0	1125	33	26
	* WRL-3A	E-3	N A	10.00W	14.6	371	52.7	1339	16.2	411	24.6	625	387	241	175.0	1125	33	26
14.00R24NHS	* RL-4J	E-4	N	10.00W	15.3	389	55.6	1412	16.7	424	25.9	658	377	234	154.0	994	48	38
	RL-5K	L-5		10.00W	15.0	381	55.8	1417	16.2	411	26.0	660	362	225	190.0	1226	81	64
	RL-5K (08/08)	L-5		10.00W	15.0	381	55.8	1417	16.2	411	26.0	660	362	225	190.0	1226	81	64
	RL-5K (12/12)	L-5		10.00W	15.0	381	55.8	1417	16.2	411	26.0	660	362	225	190.0	1226	81	64
	RL-5K (24/24)	L-5		10.00W	15.0	381	55.8	1417	16.2	411	26.0	660	362	225	190.0	1226	81	64
14.00R25NHS	RL-4J	E-4	N A	10.00	15.3	389	55.6	1412	16.7	424	25.9	658	377	234	154.0	994	48	38
16.00-25	AMS-4/5A	L-4		11.25-2.0	17.4	442	59.9	1521	19.4	493	27.6	701	343	213	200.0	1290	66	52
17.5-25	AMS D/L-4/15C	L-4		14.00-1.5	17.5	445	55.1	1400	20.0	508	24.1	612	395	245	250.0	1613	75	59
	AMS D/L-5/15C	L-5		14.00-1.5	17.5	445	55.1	1400	20.0	508	24.1	612	395	245	250.0	1613	104	82
	SMO D/L-5B	L-5S	N A	14.00-1.5	17.5	445	55.1	1400	20.0	508	25.4	644	376	234	170.0	1097	104	59
	SMO D/L-5C	L-5S	L	14.00-1.5	17.5	445	55.1	1400	20.0	508	24.1	612	395	245	250.0	1613	87	69
	UMS D/L-3A	L-3		14.00-1.5	17.7	450	53.3	1354	19.5	496	23.5	597	404	251	260.0	1677	35	28
	UMS-3A		N	14.00-1.5	18.0	457	53.5	1359	19.9	505	23.5	597	391	243	322.0	2080	35	28

Sizes in bold type can be obtained in locations in bold. Extended lead time may be needed in other locations.

Legend	N = North America L = Latin America	E = Europe / Africa / Mid East A = Asia / Australia	# = Estimated Data * = Tube Type Tire	^ = Work Capability Factor
---------------	--	--	--	----------------------------

LOAD LIMITS AT COLD INFLATION PRESSURES

5 MPH (10 KM/H) OFF-THE-ROAD UNDERGROUND MINE SERVICE

		95	100	105	110	115	120	125	130	135						
BIAS	PSI	95	100	105	110	115	120	125	130	135						
	KPA	660	690	720	760	790	830	860	900	930						
14.00-24NHS	LBS	18200	18700(20)	19300	19800	20400	20900(24)	20900	21500	22000(28)						
	KG	8250	8500(20)	8750	9000	9250	9500(24)	9500	9750	10000(28)						
RADIAL	PSI	105	109	112	116	120	123	127	131							
	KPA	725	750	775	800	825	850	875	900							
14.00R24NHS	LBS	18700	19300	19800	20400	20900**	21500	21500	22000***▲							
	KG	8500	8750	9000	9250	9500**	9750	9750	10000***▲							
BIAS	PSI	69	73	76	80	83	87	91	94	98	102	105	109			
	KPA	475	500	525	550	575	600	625	650	675	700	725	750			
16.00-25	LBS	19300	19800	20400	21500(20)	22000	22000	22700	23400(24)	24000	24700	24700	25400(28)			
	KG	8750	9000	9250	9750(20)	10000	10000	10300	10600(24)	10900	11200	11200	11500(28)			
BIAS	PSI	33	36	40	44	47	51	54	58	62	65	69	73	76	80	83
	KPA	225	250	275	300	325	350	375	400	425	450	475	500	525	550	575
17.5-25	LBS	10500	11000	11700	12300	12800	13600(12)	13900	14800(14)	15200	15700	16100(16)	16500	17100	17600	18200(20)
	KG	4750	5000	5300	5600	5800	6150(12)	6300	6700(14)	6900	7100	7300(16)	7500	7750	8000	8250(20)

Legend ▲ Permafoam inflation or special rim required

MINE SERVICE

DIMENSIONAL DATA

RADIAL

BIAS

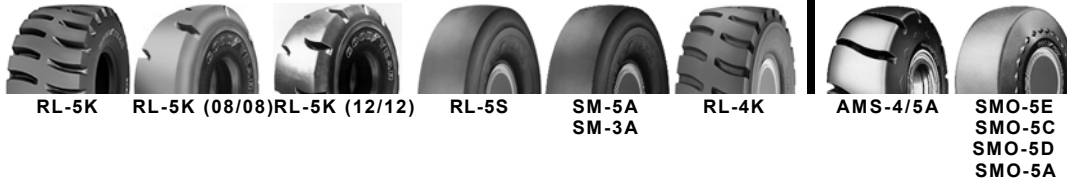

Size	Type	Ind Code	Current In Line Location	Rim Width & Flange	INFLATED DIMENSIONS				LOADED DIMENSIONS				Revol Per		Gross Contact Area		Tread Depth	
					Overall Width		Overall Diameter		Load Sect & Growth		Static Load Rad							
					in	mm	in	mm	in	mm	in	mm	mi	km	in ²	cm ²	in	mm
17.5R25	RL-4K #	L-4	E	14.00-1.5	17.8	542	55.1	1400	19.6	499	24.6	624	381	237	215.0	1389	58	46
	RL-5K	L-5		14.00-1.5	17.8	452	56.2	1427	20.2	513	24.6	624	381	237	215.0	1389	80	64
	RL-5K (08/08)	L-5	N	14.00-1.5	17.8	452	55.1	1400	20.2	513	24.6	624	381	237	215.0	1389	80	64
	RL-5K (12/12)	L-5	N	14.00-1.5	17.8	452	55.1	1400	20.2	513	24.6	624	381	237	215.0	1389	80	64
	RL-5S	L-5S	N	14.00-1.5	18.1	460	55.2	1401	19.7	500	24.6	624	381	237	196.0	1262	80	64
18.00-25	AMS-4/5A	L-4		13.00-2.5	20.1	511	66.3	1684	23.0	584	30.2	767	312	194	294.0	1897	69	55
	SMO-5C	L-5S	N L A	13.00-2.5	20.4	518	65.4	1661	22.8	580	30.1	765	311	190	265.0	1710	114	90
	SMO-5D	L-5S	N L A	13.00-2.5	20.6	523	65.6	1666	22.2	564	30.2	767	312	191	265.0	1710	102	81
	SMO-5E	L-5S	N	13.00-2.5	21.5	546	64.7	1643	22.1	561	28.9	734	321	199	255.0	1645	99	79
18.00R25	RL-5S	L-5S	N E	13.00-2.5	20.2	513	65.8	1671	21.9	557	30.6	776	319	198	349.0	2252	99	78
	SM-5A	L-5S		13.00-2.5	20.2	513	65.8	1671	21.9	557	30.6	776	319	198	327.0	2110	99	78
20.5R25	RL-5S	L-5S	E	17.00-2.0														
	SM-3A	L-3S		17.00-2.0	21.4	544	58.9	1495	23.8	605	26.3	668	357	222	330.0	2129	90	71
21.00-25	SMO-5A	L-5S	N	15.00-3.0	22.8	579	69.0	1753	24.8	630	31.9	810	295	183	336.0	2168	125	99
	SMO-5C	L-5S	A	15.00-3.0	22.8	579	69.0	1753	24.8	630	31.9	810	295	183	336.0	2168	125	99
23.5R25	RL-5S	L-5S	E	19.5-2.5	24.5	623	65.1	1654	27.3	694	29.4	747	333	207	379.0	2445	99	79
	SM-3A	L-3S		19.5-2.5	24.0	610	64.1	1628	27.2	691	28.4	722	328	204	360.0	2323		
23/90-25	SMO-5C	L-5S	N A	15.00-2.5	22.8	579	65.5	1664	24.8	630	30.2	767	312	191	305.0	1968	114	90

Sizes in bold type can be obtained in locations in bold. Extended lead time may be needed in other locations.

Legend	N = North America L = Latin America	E = Europe / Africa / Mid East A = Asia / Australia	# = Estimated Data * = Tube Type Tire	^ = Work Capability Factor
---------------	--	--	--	----------------------------

LOAD LIMITS AT COLD INFLATION PRESSURES

5 MPH (10 KM/H) OFF-THE-ROAD UNDERGROUND MINE SERVICE

	PSI	29	33	36	40	44	47	51	54	58	62	65	69	73	76	80	
RADIAL	KPA	200	225	250	275	300	325	350	375	400	425	450	475	500	525	550	Continued
17.5R25	LBS	8050	8800	9350	10200	10700	11700	12300	12800	13200	13600	14300	14800	15700*	16100	16500	
	KG	3650	4000	4250	4625	4850	5300	5600	5800	6000	6150	6500	6700	7100*	7300	7500	
	PSI	83	87	91	94	116											
	KPA	575	600	625	650	800											
	LBS	17100	17600	18200	18700**	22000***											
	KG	7750	8000	8250	8500**	10000***											
	PSI	69	73	76	80	83	87	91	94	98	102	105	109				
BIAS	KPA	475	500	525	550	575	600	625	650	675	700	725	750				
18.0R25	LBS	25400(20)	26000	26800	27600(24)	28300	29100	30000	30000(28)	30900	32000	32000	33100(32)				
	KG	11500(20)	11800	12150	12500(24)	12850	13200	13600	13600(28)	14000	14500	14500	15000(32)				
	PSI	76	80	83	87	91	94	98	102	105	109	112	116	120	131		
RADIAL	KPA	525	550	575	600	625	650	675	700	725	750	775	800	825	900		
18.0R25	LBS	24700	26000*	26800	27600	28300	29100	30000	30900	32000	33100	33100	34200	35300**	37500***		
	KG	11200	11800*	12150	12500	12850	13200	13600	14000	14500	15000	15000	15500	16000**	17000***		
	PSI	29	33	36	40	44	47	51	54	58	62	65	69	73	76	80	
RADIAL	KPA	200	225	250	275	300	325	350	375	400	425	450	475	500	525	550	Continued
20.5R25	LBS	10500	11400	12300	13200	13900	14800	15700	16500	17600	18200	19300	19800	20900*	21500	22000	
	KG	4750	5150	5600	6000	6300	6700	7100	7500	8000	8250	8750	9000	9500*	9750	10000	
	PSI	83	87	91	94												
	KPA	575	600	625	650												
	LBS	22700	24000	24700	25400**												
	KG	10300	10900	11200	11500**												
	PSI	73	78	80	83	87	91	94	98	102	105	109	112	116	120		
BIAS	KPA	500	525	550	575	600	625	650	675	700	725	750	775	800	825		
21.0R25	LBS	33100(24)	34200	35300	36400(28)	37500	37500	38600(32)	39700	40800	41900(36)	43000	43000	44100	45400(40)		
	KG	15000(24)	15500	16000	16500(28)	17000	17000	17500(32)	18000	18500	19000(36)	19500	19500	20000	20600(40)		
	PSI	29	33	36	40	44	47	51	54	58	62	65	69	73	76	80	
RADIAL	KPA	200	225	250	275	300	325	350	375	400	425	450	475	500	525	550	Continued
23.5R25	LBS	13200	14300	15700	17100	18200	19300	20400	21500	22700	23400	24700	25400	26800*	27600	28300	
	KG	6000	6500	7100	7750	8250	8750	9250	9750	10300	10600	11200	11500	12150*	12500	12850	
	PSI	83	87	91	94												
	KPA	575	600	625	650												
	LBS	29100	30000	30900	32000**												
	KG	13200	13600	14000	14500**												
	PSI	73	78	80	83	87	91	94	98								
BIAS	KPA	500	525	550	575	600	625	650	675								
23/90-25	LBS	29100	30000	30900	32000(30)	32000	33100	34200	35300(36)								
	KG	13200	13600	14000	14500(30)	14500	15000	15500	16000(36)								

Legend ▲ Permafoam inflation or special rim required

MINE SERVICE

DIMENSIONAL DATA

RADIAL

BIAS

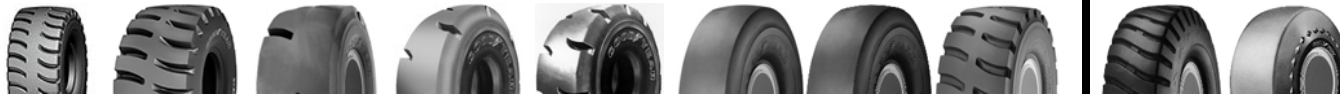

RL-4D RL-5K (24/24) RL-5K (03/03) RL-5K (08/08) RL-5K (12/12) RL-5S SM-5A RL-4K (24/24) SHRL XT D/L SMO D/L-5A
SMO D/L-5C
SMO D/L-5B
SMO D/L-5D
SMO-5C
SMO D/L-4A

Size	Type	Ind Code	Current In Line Location	Rim Width & Flange	INFLATED DIMENSIONS				LOADED DIMENSIONS				Revol Per		Gross Contact Area		Tread Depth	
					Overall Width		Overall Diameter		Load Sect & Growth		Static Load Rad							
					in	mm	in	mm	in	mm	in	mm	mi	km	in ²	cm ²	in	mm
26.5-25	SMO D/L-5B	L-5S		22.00-3.0	27.4	696	71.0	1803	29.9	759	33.0	838	286	178	409.0	2639	141	112
	SMO D/L-5C	L-5S	N A	22.00-3.0	27.4	696	71.0	1803	29.9	759	33.0	838	286	178	409.0	2639	128	102
	SMO D/L-5D	L-5S		22.00-3.0	27.4	696	71.0	1803	29.9	759	33.0	838	286	178	302.0	1948	128	102
	SMO D/L-5E	L-5S	N A	22.00-3.0	25.2	640	70.4	1788	27.5	699	31.8	808	296	184	300.0	1935	110	87
26.5R25	RL-5K (03/03)	L-5	N	22.00-3.0	27.7	703	70.2	1783	30.8	782	31.6	803	299	186	459.0	2961	110	87
	RL-5K (08/08)	L-5		22.0-3.0	27.7	703	70.2	1783	30.8	782	31.6	803	299	186	459.0	2961	110	87
	RL-5K (12/12)	L-5		22.0-3.0	27.7	703	70.2	1783	30.8	782	31.6	803	299	186	459.0	2961	110	87
	RL-5S #	L-5S	N	22.00-3.0	27.9	709	70.5	1791	31.3	795	31.6	803	299	185.8	508.9	3283	110	86.9
	SM-5A	L-5S	E A	22.0-3.0	27.7	703	70.2	1783	30.8	782	31.6	803	299	186	459.0	2961	110	87
29.5-25	SMO D/L-5A	L-5S	N	25.00-3.5	30.8	782	74.4	1890	34.2	869	34.2	869	275	171	468.0	3020	123	98
29.5R25	RL-5S	L-5S	N E	25.00-3.5	31.7	805	75.6	1920	34.9	887	33.9	861	278	173	467.9	3019	122	97
29.5-29	AMS D/L-5/8H	L-5		25.00-3.5	29.9	759	78.8	2002	32.5	826	36.8	935	256	159	486.0	3136	126	99
	SHRL XT D/L	L-4		25.00-3.5	30.8	782	78.7	1999	34.1	866	35.6	904	264	164	568.0	3665	77	61
	SMO D/L-4A	L-4S		25.00-3.5	31.3	795	78.2	1986	34.9	886	35.7	907	259	161	512.0	3303	74	58
	SMO D/L-5A	L-5S		25.00-3.5	30.1	765	78.9	2004	33.0	838	36.3	922	259	161	566.0	3652	137	108
	SMO D/L-5C	L-5S	A	25.00-3.5	30.1	765	78.9	2004	33.0	838	36.3	922	259	161	566.0	3652	137	108
	SMO-5C	L-5S	A	25.00-3.5	30.1	765	78.9	2004	33.0	838	36.3	922	259	161	566.0	3652	137	108
29.5R29	RL-4K (24/24)	L-4	N A	25.00-3.5	30.7	779	79.7	2024	34.6	879	35.0	890	264	164	554.0	3571	72	57
	RL-5K (24/24)	L-5	N	25.00-3.5	30.1	764	79.7	2024	34.2	869	35.0	890	264	164	554.0	3571	120	95
	RL-5S #	L-5S		25.00-3.5	30.1	764	79.7	2024	34.2	869	35.0	890	264	164	554.0	3571	120	95
875/65R29	RL-4D	L-4	N	27.00-3.0	33.9	860	74.0	1880	37.7	958	32.3	820	284	176	782.0	4698	72	57

Sizes in bold type can be obtained in locations in bold. Extended lead time may be needed in other locations.

Legend	N = North America L = Latin America	E = Europe / Africa / Mid East A = Asia / Australia	# = Estimated Data * = Tube Type Tire	^ = Work Capability Factor
---------------	--	--	--	----------------------------

LOAD LIMITS AT COLD INFLATION PRESSURES

5 MPH (10 KM/H) OFF-THE-ROAD UNDERGROUND MINE SERVICE

BIAS	PSI	33	36	40	44	47	51	54	58	62	65	69	73	76	80	
KPA		225	250	275	300	325	350	375	400	425	450	475	500	525	550	
26.5-25	LBS	22000(14)	24000	25400	26800	27600	29100(20)	30000	30900(24)	32000	33100(26)	34200(28)	35300	36400	37500(32)	
	KG	10000(14)	10900	11500	12150	12500	13200(20)	13600	14000(24)	14500	15000(26)	15500(28)	16000	16500	17000(32)	
RADIAL	PSI	29	33	36	40	44	47	51	54	58	62	65	69	73	76	80
	KPA	200	225	250	275	300	325	350	375	400	425	450	475	500	525	550
26.5R25	LBS	16500	18200	19800	20900	22700	24000	25400	26800	28300	29100	30900	32000	33100*	34200	35300
	KG	7500	8250	9000	9500	10300	10900	11500	12150	12850	13200	14000	14500	15000*	15500	16000
	PSI	83	87	91	94	116										
	KPA	575	600	625	650	800										
	LBS	36400	37500	39700	40800**	46700***										
	KG	16500	17000	18000	18500**	21800***										
BIAS	PSI	33	36	40	44	47	51	54	58	62	65	69	73	76		
	KPA	225	250	275	300	325	350	375	400	425	450	475	500	525		
29.5-25	LBS	26800	28300(16)	30000	32000	33100(22)	35300	36400	37500	38600(28)	40800	41900	43000	44100(34)		
	KG	12150	12850(16)	13600	14500	15000(22)	16000	16500	17000	17500(28)	18500	19000	19500	20000(34)		
RADIAL	PSI	58	62	65	69	73	76	80	83	87	91	94	116			
	KPA	400	425	450	475	500	525	550	575	600	625	650	800			
29.5R29	LBS	36400	37500	39700	40800	43000*	44100	45400	46700	49400	50700	52000**	60000***			
	KG	16500	17000	18000	18500	19500*	20000	20600	21200	22400	23000	23600**	27250***			
RADIAL	PSI	58	62	65	69	73	76	80	83	87	91					
	KPA	400	425	450	475	500	525	550	575	600	625					
875/65R29	LBS	40800	43000	44100	46700*	48100	49400	52000	53600	55100	56800**					
	KG	18500	19500	20000	21200*	21800	22400	23600	24300	25000	25750**					

Continued

Legend

▲ Permafoam inflation or special rim required

MINE SERVICE

RADIAL



RL-5S

RL-4K

DIMENSIONAL DATA

Size	Type	Ind Code	Current In Line Location	Rim Width & Flange	INFLATED DIMENSIONS				LOADED DIMENSIONS				Revol Per		Gross Contact Area		Tread Depth	
					Overall Width		Overall Diameter		Load Sect & Growth		Static Load Rad							
					in	mm	in	mm	in	mm	in	mm	mi	km	in ²	cm ²	1/32	mm
35/65R33 (875/65R33)	RL-4K	L-4	N	28.00-3.5	35.6	904	81.9	2079	38.7	982	36.9	937	257	159	686.0	4426	73	58
	RL-5K 05/10	L-5		28.00-3.5	35.6	904	81.9	2079	38.7	982	36.9	937	257	159	686.0	4426	120	95
	RL-5S	L-5S		28.00-3.5	35.6	904	81.9	2079	38.7	982	36.9	937	257	159	686.0	4426	120	95
875/65R33 (35/65R33)	RL-5K 05/10	L-5		28.00-3.5	35.6	904	81.9	2079	38.7	982	36.9	937	257	159	686.0	4426	120	95
	RL-5S	L-5S	N E	28.00-3.5	35.6	904	81.9	2079	38.7	982	36.9	937	257	159	686.0	4426	120	95

Sizes in bold type can be obtained in locations in bold.
Extended lead time may be needed in other locations.

Legend	N = North America	E = Europe / Africa / Mid East	# = Estimated Data	^ = Work Capability Factor
	L = Latin America	A = Asia / Australia	* = Tube Type Tire	

LOAD LIMITS AT COLD INFLATION PRESSURES

5 MPH (10 KM/H) OFF-THE-ROAD UNDERGROUND MINE SERVICE

RADIAL	PSI KPA	58 400	62 425	65 450	69 475	73 500	76 525	80 550	83 575	87 600	91 625	94 650
875/65R33	LBS	43000	45400	46700	49400	50700*	52000	55100	56800	58400	60000	61500**
(35/65R33)	KG	19500	20600	21200	22400	23000*	23600	25000	25750	26500	27250	28000**

Legend

▲ Permafoam inflation or special rim required

DRIVE AWAY

**LOAD AND INFLATION TABLES: English
CONVENTIONAL SIZE TIRES
MAXIMUM SPEED - 30 MPH
(MINIMUM INFLATION PRESSURE - 25 PSI)**

These loads and inflations are used for drive away only.
They cannot be used for jobsite roading.

DANGER: Operation of vehicles over the road, ignoring speed limitations and cooling requirements as noted below, can void tire warranty and induce premature tire failure!

TIRE LOAD LIMITS (POUNDS) AT VARIOUS COLD INFLATION PRESSURES - POUNDS PER SQUARE INCH (PSI)

Tire Size	25	30	35	40	45	50	55	60	65	70	75	80	85	90	95	100
12.00-20,21 NHS	2690	2990	3260	3540	3780	4020	4260	4480	4700	4900	5100	5300	5500	5680	5860	6050
12.00-24,25 NHS	3020	3360	3680	3980	4260	4540	4800	5040	5280	5520	5740	5960	6200	6400	6600	6800
13.00-24,25 NHS	3500	3880	4260	4600	4920	5240	5540	5820	6100	6400	6650	6900	7150	7400	7600	7850
14.00-20,21 NHS	3680	4100	4500	4860	5200	5540	5860	6150	6450	6750	7000	7300	7550	7800	8050	8300
14.00-24,25 NHS	4120	4580	5020	5420	5800	6200	6550	6850	7200	7500	7850	8150	8450	8700	9000	9250
16.00-21 NHS	4920	5460	5980	6450	6950	7350	7800	8200	8600	8950	9350	9700	10100	10400	10700	11100
16.00-25	5380	5980	6550	7100	7600	8050	8550	9000	9400	9850	10200	10600	11000	11400	11800	12100
18.00-25	6950	7750	8500	9150	9800	10400	11000	11600	12200	12700	13200	13700	14200	14700	15200	15700
18.00-33	8050	9000	9850	10600	11400	12100	12800	13500	14100	14700	15400	15900	16500	17100	17600	18200
18.00-49	10200	11400	12400	13400	14400	15300	16200	17000	17800	18600	19400	20200	20900	21600	22300	23000
21.00-25	8950	9950	10900	11800	12600	13400	14200	14900	15700	16400	17000	17700	18300	18900	19600	20200
21.00-35	10600	11800	12900	14000	15000	15900	16900	17700	18600	19400	20200	21000	21700	22500	23200	23900
21.00-49	12900	14300	15700	17000	18200	19300	20400	21500	22500	23500	24500	25400	26300	27200	28100	29000
24.00-25	11600	12900	14100	15200	16300	17400	18400	19300	20200	21100	22000	22900	23700	24500	25300	26000
24.00-29	12400	13800	15100	16300	17500	18600	19700	20700	21700	22600	23600	24500	25400	26200	27100	27900
24.00-35	13600	15100	16600	17900	19200	20400	21600	22700	23800	24800	25800	26800	27800	28800	29700	30600
24.00-43	15200	16900	18500	20000	21400	22700	24000	25300	26500	27700	28800	29900	31000	32100	33100	34100
24.00-49	16300	18100	19900	21500	23000	24500	25900	27200	28500	29800	31000	32200	33400	34500	35600	36700

BIAS - 30 MPH
ADD 10 PSI FOR RADIAL
English

For Service Notes – See next page.
Contact your Rim Supplier regarding information on Rim Strength.

**LOAD AND INFLATION TABLES: English
CONVENTIONAL SIZE TIRES
MAXIMUM SPEED - 30 MPH
(MINIMUM INFLATION PRESSURE - 25 PSI)**

These loads and inflations are used for drive away only.
They cannot be used for jobsite roading.

DANGER: Operation of vehicles over the road, ignoring speed limitations and cooling requirements as noted below, can void tire warranty and induce premature tire failure!

TIRE LOAD LIMITS (POUNDS) AT VARIOUS COLD INFLATION PRESSURES - POUNDS PER SQUARE INCH (PSI)

Tire Size	25	30	35	40	45	50	55	60	65	70	75	80	85	90	95	100
27.00-33	16200	18100	19800	21400	22900	24400	25800	27100	28400	29700	30900	32100	33200	34400	35500	36600
27.00-49	20000	22200	24300	36300	28200	30000	31700	33300	34900	36500	38000	39400	40900	42300	43600	44900
30.00-51	24700	27500	30100	32500	34900	37100	39200	41300	43200	45200	47000	48800	50600	52300	54000	55600
33.00-51	28600	31900	34900	37700	40400	43000	45400	47800	50100	52300	54500	56500	58600	60500	62500	64500
36.00-51	34900	38800	42500	45900	49200	52300	55300	58200	61000	63500	65500	69000	71500	74000	76000	78500
40.00-57	44500	49600	54200	58600	63000	67000	70500	74500	78000	81500	84500	88000	91000	94000	97500	100000

BIAS - 30 MPH
ADD 10 PSI FOR RADIAL
English

Service Notes

- Regular Tread Tires
 - Maximum Highway Speeds: Conventional tires – 30 MPH, Wide Base Tires – 20 MPH.
 - Stop for 30 minute cooling period after each 50 miles of driving or 2 hours of sustained operation, whichever comes first.
 - One hour minimum stop should be observed after each 4 hours of operation.
 - Where Conventional and Wide Base tires are mixed on vehicle, use guidelines specified for Wide Base tires.
- Extra Skid Depth and Special Compound Tires
 - Vehicles equipped with extra skid depth tires are not to be driven in transit over the highway unless the proposed trip is reviewed and approved by the tire manufacturer.
- Instructions for Use of Drive-Away Table
 - Determine the load each tire will carry.
 - Using the table, select the inflation pressure shown for the tire load determined. This is the pressure required for drive-away service.
 - Tire ply rating is ignored when determining drive-away load and pressure conditions.

Contact your Rim Supplier regarding information on Rim Strength.

LOAD AND INFLATION TABLES: English
WIDE BASE SIZE TIRES
MAXIMUM SPEED - 20 MPH
(MINIMUM INFLATION PRESSURE - 26 PSI)

These loads and inflations are used for drive away only.
 They cannot be used for jobsite roading.

DANGER: Operation of vehicles over the road, ignoring speed limitations and cooling requirements as noted below, can void tire warranty and induce premature tire failure!

TIRE LOAD LIMITS (POUNDS) AT VARIOUS COLD INFLATION PRESSURES - POUNDS PER SQUARE INCH (PSI)

Tire Size	25	30	35	40	45	50	55	60	65	70	75	80	85	90	95	100
15.5-25	3740	4160	4540	4920	5260	5600	5920	6250	6550	6800	7100	7400	7650	7900	8150	8400
17.5-25	4460	4960	5440	5880	6300	6700	7100	7450	7800	8150	8500	8800	9150	9450	9750	10000
20.5-25	5960	6650	7250	7850	8400	8950	9450	9950	10400	10900	11300	11800	12200	12600	13000	13400
23.5-25	7600	8450	9250	10000	10700	11400	12100	12700	13300	13900	14500	15000	15600	16100	16600	17100
26.5-25	9550	10600	11600	12600	13500	14300	15200	16000	16700	17500	18200	18900	19600	20200	20900	21500
26.5-29	10200	11400	12400	13400	14400	15300	16200	17000	17900	18700	19400	20200	20900	21600	22300	23000
29.5-25	11500	12800	14000	15200	16300	17300	18300	19200	20200	21000	21900	22800	23600	24400	25200	25900
29.5-29	12300	13700	14900	16200	17300	18400	19500	20500	21500	22400	23300	24200	25100	26000	26800	27600
29.5-35	13400	14900	16300	17600	18800	20000	21200	22300	23400	24400	25400	26400	27300	28300	29200	30100
33.25-29	15100	16800	18400	19900	21300	22700	24000	25200	26500	27600	28800	29900	30900	32000	33000	34000
33.25-35	16400	18200	20000	21600	23100	24600	26000	27400	28700	29900	31200	32400	33500	34700	35800	36900
33.5-33	16500	18400	20100	21700	23300	24800	26200	27500	28900	30100	31400	32600	33800	34900	36000	37100
33.5-39	17800	19800	21600	23400	25100	26700	28200	29700	31100	32500	33800	35100	36400	37600	38800	40000
37.25-35	19800	22000	24100	26000	27900	29600	31300	33000	34500	36100	37600	39000	40400	41800	43100	44400
37.5-33	19800	22100	24200	26100	28000	29800	31500	33100	34700	36200	37700	39200	40600	42000	43300	44700
37.5-39	21300	23700	25900	28000	30000	32000	33800	35600	37300	38900	40500	42100	43600	45100	46500	47900
37.5-51	24100	26800	29300	31700	34000	36100	38200	40200	41200	44000	45800	47600	49300	51000	52600	54200

BIAS - 20 MPH
 ADD 10 PSI FOR RADIAL
 English

Service Notes

- Regular Tread Tires
 - Maximum Highway Speeds: Conventional tires – 30 MPH, Wide Base Tires – 20 MPH.
 - Stop for 30 minute cooling period after each 50 miles of driving or 2 hours of sustained operation, whichever comes first.
 - One hour minimum stop should be observed after each 4 hours of operation.
 - Where Conventional and Wide Base tires are mixed on vehicle, use guidelines specified for Wide Base tires.
- Extra Skid Depth and Special Compound Tires
 - Vehicles equipped with extra skid depth tires are not to be driven in transit over the highway unless the proposed trip is reviewed and approved by the tire manufacturer.
- Instructions for Use of Drive-Away Table
 - Determine the load each tire will carry.
 - Using the table, select the inflation pressure shown for the tire load determined. This is the pressure required for drive-away service.
 - Tire ply rating is ignored when determining drive-away load and pressure conditions.

Contact your Rim Supplier regarding information on Rim Strength.

DRIVE AWAY

**LOAD AND INFLATION TABLES: Metric
CONVENTIONAL SIZE TIRES
MAXIMUM SPEED - 50 KPH
(MINIMUM INFLATION PRESSURE - 1.75 BAR**

These loads and inflations are used for drive away only.
They cannot be used for jobsite roading.

DANGER: Operation of vehicles over the road, ignoring speed limitations and cooling requirements as noted below, can void tire warranty and induce premature tire failure!

TIRE LOAD LIMITS (KILOGRAMS) AT VARIOUS COLD INFLATION PRESSURES - BAR

Tire Size	1.75	2.00	2.25	2.50	2.75	3.00	3.25	3.50	3.75	4.00	4.25	4.50	4.75	5.00	5.25	5.50	5.75	6.00	6.25	6.50	6.75	7.00
12.00-20,21 NHS	1215	1320	1400	1500	1600	1700	1750	1850	1900	2000	2060	2120	2180	2300	2360	2430	2430	2500	2575	2650	2725	2800
12.00-24,25 NHS	1400	1500	1600	1700	1800	1900	2000	2060	2180	2240	2300	2430	2500	2575	2650	2725	2800	2800	2900	3000	3075	3075
13.00-24,25 NHS	1600	1750	1850	2000	2060	2180	2300	2430	2500	2575	2750	2800	2900	3000	3075	3150	3250	3250	3350	3450	3550	3650
14.00-20,21 NHS	1700	1850	1950	2060	2180	2300	2430	2575	2650	2725	2800	2900	3000	3150	3250	3350	3350	3450	3550	3650	3750	3750
14.00-24,25 NHS	1900	2060	2180	2300	2430	2575	2725	2800	3000	3075	3150	3250	3350	3450	3550	3650	3750	3875	4000	4125	4125	4250
16.00-21 NHS	2240	2430	2575	2800	2900	3075	3250	3350	3550	3650	3750	3875	4000	4125	4250	4375	4500	4625	4750	4875	5000	5000
16.00-25	2430	2650	2900	3000	3250	3350	3550	3650	3875	4000	4125	4250	4375	4500	4625	4875	5000	5000	5150	5300	5450	5600
18.00-25	3150	3450	3650	3875	4125	4375	4625	4750	5000	5150	5300	5600	5800	5800	6000	6300	6300	6500	6700	6900	7100	7100
18.00-33	3650	4000	4250	4500	4875	5000	5300	5600	5800	6000	6150	6500	6700	6900	7100	7300	7500	7500	7750	8000	8250	8250
18.00-49	4625	5000	5450	5800	6150	6500	6700	7100	7300	7500	7750	8000	8500	8750	9000	9250	9500	9500	9750	10000	10300	10600
21.00-25	4125	4375	4750	5000	5300	5600	5800	6150	6300	6700	6900	7100	7300	7500	7750	8000	8250	8500	8500	8750	9000	9250
21.00-35	4875	5300	5600	6000	6300	6700	6900	7300	7500	7750	8250	8500	8750	9000	9250	9500	9750	10000	10300	10600	10600	10900
21.00-49	5800	6300	6900	7300	7750	8000	8500	8750	9250	9500	10000	10300	10600	10900	11200	11500	11800	12150	12500	12500	12850	13200
24.00-25	5300	5800	6150	6500	6900	7300	7500	8000	8250	8500	9000	9250	9500	9750	10000	10300	10600	10900	11200	11500	11800	11800
24.00-29	5600	6150	6500	6900	7300	7750	8250	8500	8750	9250	9500	9750	10300	10600	10900	11200	11500	11800	11800	12150	12500	12850
24.00-35	6150	6700	7300	7750	8000	8500	9000	9250	9750	10000	10600	10900	11200	11500	11800	12150	12500	12850	13200	13600	13600	14000
24.00-43	6900	7500	8000	8500	9000	9500	10000	10300	10900	11200	11800	12150	12500	12850	13200	13600	14000	14500	14500	15000	15500	15500
24.00-49	7500	8000	8750	9250	9750	10300	10600	11200	11800	12150	12500	12850	13200	13600	14000	14500	15000	15500	15500	16000	16500	17000

BIAS - 50 KPH
ADD 0.75 BAR FOR RADIAL
Metric

For Service Notes – See next page.
Contact your Rim Supplier regarding information on Rim Strength.

**LOAD AND INFLATION TABLES: Metric
CONVENTIONAL SIZE TIRES
MAXIMUM SPEED - 50 KPH
(MINIMUM INFLATION PRESSURE - 1.75 BAR**

These loads and inflations are used for drive away only.
They cannot be used for jobsite roading.

DANGER: Operation of vehicles over the road, ignoring speed limitations and cooling requirements as noted below, can void tire warranty and induce premature tire failure!

TIRE LOAD LIMITS (KILOGRAMS) AT VARIOUS COLD INFLATION PRESSURES - BAR

Tire Size	1.75	2.00	2.25	2.50	2.75	3.00	3.25	3.50	3.75	4.00	4.25	4.50	4.75	5.00	5.25	5.50	5.75	6.00	6.25	6.50	6.75	7.00
27.00-33	7500	8000	8500	9250	9750	10300	10600	11200	11500	12150	12500	12850	13200	13600	14000	14500	15000	15500	15500	16000	16500	16500
27.00-49	9250	10000	10600	11200	11800	12500	13200	13600	14500	15000	15500	16000	16500	17000	17500	18000	18500	19000	19500	19500	20000	20600
30.00-51	11200	12150	13200	14000	14500	15500	16000	17000	17500	18500	19000	19500	20000	21200	21800	22400	22400	23000	23600	24300	25000	25750
33.00-51	13200	14000	15000	16000	17000	18000	19000	19500	20600	21200	21800	23000	23600	24300	25000	25750	26500	27250	27250	28000	29000	29000
36.00-51	16000	17500	18500	19500	20600	21800	23000	23600	25000	25750	26500	28000	29000	29000	30000	31500	32500	32500	33500	34500	35500	35500
40.00-57	20600	21800	23600	25000	26500	28000	29000	30750	31500	33500	34500	35500	36500	37500	38750	40000	41250	41250	42500	43750	45000	46250

BIAS - 50 KPH
ADD 0.75 BAR FOR RADIAL
Metric

Service Notes

- Regular Tread Tires
 - Maximum Highway Speeds: Conventional tires – 50 KPH, Wide Base Tires – 30 KPH.
 - Stop for 30 minute cooling period after each 50 miles of driving or 2 hours of sustained operation, whichever comes first.
 - One hour minimum stop should be observed after each 4 hours of operation.
 - Where Conventional and Wide Base tires are mixed on vehicle, use guidelines specified for Wide Base tires.
- Extra Skid Depth and Special Compound Tires
 - Vehicles equipped with extra skid depth tires are not to be driven in transit over the highway unless the proposed trip is reviewed and approved by the tire manufacturer.
- Instructions for Use of Drive-Away Table
 - Determine the load each tire will carry.
 - Using the table, select the inflation pressure shown for the tire load determined. This is the pressure required for drive-away service.
 - Tire ply rating is ignored when determining drive-away load and pressure conditions.

Contact your Rim Supplier regarding information on Rim Strength.

LOAD AND INFLATION TABLES: Metric
WIDE BASE SIZE TIRES
MAXIMUM SPEED - 32 KPH
(MINIMUM INFLATION PRESSURE - 1.75 BAR)

These loads and inflations are used for drive away only.
 They cannot be used for jobsite roading.

DANGER: Operation of vehicles over the road, ignoring speed limitations and cooling requirements as noted below, can void tire warranty and induce premature tire failure!

TIRE LOAD LIMITS (KILOGRAMS) AT VARIOUS COLD INFLATION PRESSURES - BAR

Tire Size	1.75	2.00	2.25	2.50	2.75	3.00	3.25	3.50	3.75	4.00	4.25	4.50	4.75	5.00	5.25	5.50	5.75	6.00	6.25	6.50	6.75	7.00
15.5-25	1700	1850	2000	2120	2240	2360	2430	2575	2650	2800	2900	3000	3075	3150	3250	3350	3450	3550	3650	3650	3750	3875
17.5-25	2060	2180	2360	2500	2650	2800	2900	3075	3150	3350	3450	3550	3650	3750	3875	4000	4125	4250	4250	4375	4500	4625
20.5-25	2725	3000	3150	3350	3550	3750	3875	4125	4250	4375	4625	4750	4875	5000	5150	5300	5450	5600	5800	5800	6000	6150
23.5-25	3450	3750	4000	4250	4500	4750	5000	5300	5450	5600	5800	6000	6300	6500	6700	6900	6900	7100	7300	7500	7750	7750
26.5-25	4375	4750	5000	5450	5600	6000	6300	6500	6900	7100	7300	7500	7750	8000	8250	8500	8750	9000	9250	9500	9750	9750
26.5-29	4625	5000	5450	5800	6150	6500	6700	7100	7300	7500	7750	8000	8500	8750	9000	9250	9250	9500	9750	10000	10300	10600
29.5-25	5300	5800	6150	6500	6900	7300	7500	8000	8250	8500	8750	9250	9500	9750	10000	10300	10600	10900	11200	11500	11500	11800
29.5-29	5600	6000	6500	6900	7300	7750	8000	8500	8750	9000	9500	9750	10000	10300	10600	10900	11200	11500	11800	12150	12500	12500
29.5-35	6150	6700	7100	7500	8000	8500	8750	9250	9500	10000	10300	10600	10900	11200	11500	11800	12150	12500	12850	13200	13600	13600
33.25-29	6900	7500	8000	8500	9000	9500	10000	10300	10900	11200	11500	12150	12500	12850	13200	13600	14000	14000	14500	15000	15000	15500
33.25-35	7500	8000	8750	9250	9750	10300	10900	11200	11800	12150	12500	13200	13600	14000	14500	14500	15000	15500	16000	16000	16500	17000
33.5-33	7500	8250	8750	9250	9750	10300	10900	11200	11800	12150	12850	13200	13600	14000	15000	14500	15000	15500	16000	16500	16500	17000
33.5-39	8250	8750	9500	10000	10600	11200	11800	12150	12850	13200	13600	14000	14500	15000	15500	16000	16500	16500	17000	17500	18000	18500
37.25-35	9000	9750	10600	11200	11800	12500	12850	13600	14000	14500	15000	15500	16000	17000	17000	17500	18000	18500	19000	19500	20000	20600
37.5-33	9000	9750	10600	11200	11800	12500	13200	13600	14000	14500	15000	16000	16500	16500	17000	17500	18000	18500	19000	19500	20000	20600
37.5-39	9750	10600	11200	12150	12850	13200	14000	14500	15000	16000	16500	17000	17500	18000	18500	19000	19500	20000	20600	21200	21200	21800
37.5-51	10900	11800	12850	13600	14500	15000	16000	16500	17000	18000	18500	19000	20000	20600	21200	21800	21800	22400	23000	23600	24300	25000

BIAS - 32 KPH
 ADD 0.75 BAR FOR RADIAL
 Metric

Service Notes

- Regular Tread Tires
 - Maximum Highway Speeds: Conventional tires – 50 KPH, Wide Base Tires – 32 KPH.
 - Stop for 30 minute cooling period after each 80 miles of driving or 2 hours of sustained operation, whichever comes first.
 - One hour minimum stop should be observed after each 4 hours of operation.
 - Where Conventional and Wide Base tires are mixed on vehicle, use guidelines specified for Wide Base tires.
- Extra Skid Depth and Special Compound Tires
 - Vehicles equipped with extra skid depth tires are not to be driven in transit over the highway unless the proposed trip is reviewed and approved by the tire manufacturer.
- Instructions for Use of Drive-Away Table
 - Determine the load each tire will carry.
 - Using the table, select the inflation pressure shown for the tire load determined. This is the pressure required for drive-away service.
 - Tire ply rating is ignored when determining drive-away load and pressure conditions.

Contact your Rim Supplier regarding information on Rim Strength.

LOAD INDEX SPEED SYMBOL MARKINGS

SPEED SYMBOL	SPEED	
	KMH	MPH
A1	5	2.5
A2	10	5
A3	15	10
A4	20	12.5
A5	25	15
A6	30	20
A7	35	22.5
A8	40	25
B	50	30
C	60	35
D	65	40
E	70	43
F	80	50
G	90	55
J	100	62

SPEED SYMBOL

A symbol indicating the speed at which the tire can carry a load corresponding to its Load Index under specified service conditions.

LOAD INDEX

A numerical code associated with the maximum load a tire can carry at the speed indicated by its Speed Symbol under specified service conditions.

SERVICE DESCRIPTION

A service designation which is distinct from size designation, consisting of the Load Index and Speed Symbol.

EXAMPLE - 525/80R25 179E

LOAD INDEX - KILOGRAM LOADS, AND TRA EQUIVALENT POUND LOADS

LI	kg	lbs.	LI	kg	lbs.	LI	kg	lbs.	LI	kg	lbs.
0	45	99	40	140	310	80	450	990	120	1400	3080
1	46.2	102	41	145	320	81	462	1020	121	1450	3200
2	47.5	105	42	150	330	82	475	1050	122	1500	3300
3	48.7	107	43	155	340	83	487	1070	123	1550	3420
4	50	110	44	160	355	84	500	1100	124	1600	3520
5	51.5	114	45	165	365	85	515	1140	125	1650	3640
6	53	117	46	170	375	86	530	1170	126	1700	3740
7	54.5	120	47	175	385	87	545	1200	127	1750	3860
8	56	123	48	180	395	88	560	1230	128	1800	3960
9	58	128	49	185	410	89	580	1280	129	1850	4080
10	60	132	50	190	420	90	600	1320	130	1900	4180
11	61.5	136	51	195	430	91	615	1360	131	1950	4300
12	63	139	52	200	440	92	630	1390	132	2000	4400
13	65	143	53	206	455	93	650	1430	133	2060	4540
14	67	148	54	212	465	94	670	1480	134	2120	4680
15	69	152	55	218	480	95	690	1520	135	2180	4800
16	71	157	56	224	495	96	710	1570	136	2240	4940
17	73	161	57	230	505	97	730	1610	137	2300	5080
18	75	165	58	236	520	98	750	1650	138	2360	5200
19	77.5	170	59	243	535	99	775	1710	139	2430	5360
20	80	175	60	250	550	100	800	1760	140	2500	5520
21	82.5	180	61	257	565	101	825	1820	141	2575	5680
22	85	185	62	265	585	102	850	1870	142	2650	5840
23	87.5	195	63	272	600	103	875	1930	143	2725	6000
24	90	200	64	280	615	104	900	1980	144	2800	6150
25	92.5	205	65	290	640	105	925	2040	145	2900	6400
26	95	210	66	300	660	106	950	2090	146	3000	6600
27	97.5	215	67	307	675	107	975	2150	147	3075	6800
28	100	220	68	315	695	108	1000	2200	148	3150	6950
29	103	225	69	325	715	109	1030	2270	149	3250	7150
30	106	235	70	335	740	110	1060	2340	150	3350	7400
31	109	240	71	345	760	111	1090	2400	151	3450	7600
32	112	245	72	355	785	112	1120	2470	152	3550	7850
33	115	255	73	365	805	113	1150	2540	153	3650	8050
34	118	260	74	375	825	114	1180	2600	154	3750	8250
35	121	265	75	387	855	115	1215	2680	155	3875	8550
36	125	275	76	400	880	116	1250	2760	156	4000	8800
37	128	280	77	412	910	117	1285	2830	157	4125	9100
38	132	290	78	425	935	118	1320	2910	158	4250	9350
39	136	300	79	437	965	119	1360	3000	159	4375	9650

LOAD INDEX - KILOGRAM LOADS, AND TRA EQUIVALENT POUND LOADS

LI	kg	lbs.	LI	kg	lbs.	LI	kg	lbs.	LI	kg	lbs.
160	4500	9900	192	11200	24700	224	28000	61500	256	71000	156500
161	4625	10200	193	11500	25400	225	29000	64000	257	73000	161000
162	4750	10500	194	11800	26000	226	30000	66000	258	75000	165500
163	4875	10700	195	12150	26800	227	30750	68000	259	77500	171000
164	5000	11000	196	12500	27600	228	31500	69500	260	80000	176500
165	5150	11400	197	12850	28300	229	32500	71500	261	82500	182000
166	5300	11700	198	13200	29100	230	33500	74000	262	85000	187500
167	5450	12000	199	13600	30000	231	34500	76000	263	87500	193000
168	5600	12300	200	14000	30900	232	35500	78500	264	90000	198500
169	5800	12800	201	14500	32000	233	36500	80500	265	92500	204000
170	6000	13200	202	15000	33100	234	37500	82500	266	95000	209500
171	6150	13600	203	15500	34200	235	38750	85500	267	97500	215000
172	6300	13900	204	16000	35300	236	40000	88000	268	100000	220500
173	6500	14300	205	16500	36400	237	41250	91000	269	103000	227000
174	6700	14800	206	17000	37500	238	42500	93500	270	106000	233500
175	6900	15200	207	17500	38600	239	43750	96500	271	109000	240500
176	7100	15700	208	18000	39700	240	45000	99000	272	112000	247000
177	7300	16100	209	18500	40800	241	46250	102000	273	115000	253500
178	7500	16500	210	19000	41900	242	47500	104500	274	118000	260000
179	7750	17100	211	19500	43000	243	48750	107500	275	121000	267000
180	8000	17600	212	20000	44100	244	50000	110000	276	125000	275500
181	8250	18200	213	20600	45400	245	51500	113500	277	128500	283500
182	8500	18700	214	21200	46700	246	53000	117000	278	132000	291000
183	8750	19300	215	21800	48100	247	54500	120000	279	136000	300000
184	9000	19800	216	22400	49400	248	56000	123500	280	140000	308500
185	9250	20400	217	23000	50700	249	58000	128000	281	145000	319500
186	9500	20900	218	23600	52000	250	60000	132500	282	150000	330500
187	9750	21500	219	24300	53600	251	61500	135500	283	155000	341500
188	10000	22000	220	25000	55100	252	63000	139000	284	160000	353000
189	10300	22700	221	25750	56800	253	65000	143500	285	165000	364000
190	10600	23400	222	26500	58400	254	67000	147500	286	170000	375000
191	10900	24000	223	27250	60000	255	69000	152000	287	175000	386000

LOAD/SPEED VARIATIONS HIGHWAY

FOR EARTHMOVER TIRES
USED IN SUSTAINED HIGHWAY USE

1. T&RA STANDARD BASED UPON LOAD AT 90 KMH

Operating Speed		% Load Change
KMH	MPH	
30	20	+86%
40	25	+77%
50	30	+69%
60	35	+60%
70	43	+43%
80	50	+17%
90	55	No Change
100	62	-14%

2. ETRTO STANDARD BASED UPON RATED LOAD AT 70 KMH

Operating Speed		% Load Change
KMH	MPH	
30	20	+30%
40	25	+24%
50	30	+18%
60	35	+12%
70	43	No Change
80	50	-18%
90	55	-30%
100	62	-40%

These tables apply to AT-2A, MC-1A and metric sized GP-2B tire sizes only.

LOAD/SPEED VARIATIONS OFF-THE-ROAD

1. EARTHMOVER 40MPH (65 KPH) SERVICE

T&RA (English)		ETRTO (Metric)	
Aspect Ratio	% Change (from 30 MPH)	Aspect Ratio	% Change (from 50 KPH)
Bias Conventional	-15%	Bias Conventional	-15%
Bias Wide Base	-17%	Bias Wide Base	-17%
Radial	-12%	Radial	-12%

2. GRADER SERVICE

T&RA (English)		ETRTO (Metric)	
Max Speed	% Change (from 25 MPH)	Max Speed	% Change (from 40 KPH)
30	-9%	50	-9%
35	-18%	60	-18%
40	-27%	65	-27%

3. EARTHMOVER AND INDUSTRIAL VEHICLE SPEED SERVICE

T&RA (English)		ETRTO (Metric)	
Max Speed	% Change (from 5 MPH)	Max Speed	% Change (from 10 KPH)
Static	+60%	Static	+60%
Creep	+30%	1 KPH	+30%
2 1/2 MPH	+15%	5 KPH	+13%
5 MPH	No Change	10 KPH	No Change
10 MPH	-13%	15 KPH	-7%
15 MPH	-20%	20 KPH	-12%
20 MPH	-26%**	25 KPH	-15%
25 MPH	-32%**		

4. INDUSTRIAL VEHICLE SERVICE* ON SMOOTH FLOORS & RUNWAYS

T&RA (English)		ETRTO (Metric)	
Max Speed	% Change (from 5 MPH)#	Max Speed	% Change (from 10 KPH)#
Static	+80%	Static	+80%
Creep	+60%	1 KPH	+60%
2 1/2 MPH	+45%	5 KPH	+45%
5 MPH	+35%	10 KPH	+35%
10 MPH	+30%	15 KPH	+30%
15 MPH	+25%	20 KPH	+27%
20 MPH	+18%**	25 KPH	+25%

* For coil haulers, log stackers, and straddle carriers the item 3 loads are maximums. For container handlers, piggy-packers and industrial fork lift trucks Goodyears warranty allowance applies to the 2 1/2 MPH and 5 KPH factors only. Travel distance limited to 2500 ft.

** Goodyear allowance

For inflation pressure use 5 MPH/10 KPH inflations times 1.20. For steer wheel on fork lift trucks multiply the industrial vehicle ratings by 0.8.

Contact your Rim Supplier regarding information on rim strength.

APPROXIMATE SHIPPING DATA

Size/Type	Tire Cubeage		Tire Weight	
	Ft ³	M ³	Lbs	Kg
105-20 10 IND SG MPT NYTL	8.9	0.25	66	30
1150/65R45 244/A2 2X RL5K HS05/05L56STL	282.6	8.00	6171	2799
1150/65R45 244/A2 2X RL5K HS20/20L56STL	282.6	8.00	5869	2662
1150/65R45 2X RL5K H-S 20/20 L5 4S RPTL	282.6	8.00	5801	2631
1200-20 16 HRL3A NYTT	15.4	0.44	193	88
1200-20 16 HRL3A NYTTT/C60505	14.0	0.40	203	92
1200-20 20 UMS3A 6S NYTT	15.4	0.44	223	101
1200-20 20 UMS3A 6S NYTT C60505	14.0	0.40	233	106
1200-20 20 UMS3A 6S NYTT N0000	14.0	0.40	223	101
1200-20 28 UMS3A 6S TT	14.7	0.42	253	115
1200-20 28 UMS3A 6S TT N0000	19.9	0.56	253	115
1200-24 16 HRL3A NYTT	18.2	0.51	216	98
1200-24 16 HRL3A NYTTT/C60505	16.6	0.47	232	105
1200-24 16 UMS3A 6S NYTT	18.2	0.51	237	107
1200-24 20 SMO-5B 6S NYTT	17.4	0.49	406	184
1200R20NHS 3X EV-5S IND5 TL	14.7	0.42	361	164
1200R20NHS 3X RL-5K 00/24 L5 6S TL	14.7	0.42	339	154
1200R20NHS 3X RL-5K 08/08 L5 6S TL	14.7	0.42	316	143
1200R20NHS 3X RL-5K 08/08 L5 6S TL N0000	28.1	0.80	316	143
1200R20NHS 3X RL-5K 12/12 L5 6S TL	14.7	0.42	374	169
1200R20NHS 3X RL-5K 12/12 L5 6S TL N0000	28.1	0.80	374	169
1200R20NHS 3X RL-5S L5S 6S TL	14.7	0.42	366	166
1200R20NHS 3X RL5K 24/24 L5 6S TL	14.7	0.42	330	150
1200R20NHS 3X RL5K 24/24 L5 6S TL	14.7	0.42	330	150
1200R24 3X RL4J E4 4S TT	19.5	0.55	312	142
125-20 10 IND SG MPT NYTL	12.5	0.35	84	38
1300-20 10 SGG2A NYTT	17.3	0.49	129	59
1300-20 10 SGG2A NYTTT/C60505	16.4	0.47	140	64
1300-24 10 SGG2A G2 TL	21.1	0.60	195	89
1300-24 10 SGG2A G2 TT	21.1	0.60	195	89
1300-24 12 SGG2A NYTL	21.1	0.60	168	76
1300-24 12 SGG2A NYTT	21.1	0.60	172	78
1300-24TG 10 SGG2A G2 TL	21.1	0.60	195	89
1300-24TG 10 SGG2A G2 TL	21.1	0.60	195	89
1300-24TG 10 SGG2A G2 TT	21.1	0.60	195	89
1300-24TG 12 SGG2A G2 TL	21.1	0.60	195	89
1300-24TG 12 SGG2A G2 TL	21.1	0.60	195	89
1300-24TG 12 SGG2A G2 TT	21.1	0.60	195	89
1300-24TG 12 SGG2A G2 TT	21.1	0.60	195	89
1300-24TG 12 SGG2A G2 TT	21.1	0.60	195	89
14.00R24TG 00 AS-3A G-3 TL	25.0	0.71	314	142
14.00R24TG 00 AS-3A G-3 TL P0E5170-	25.0	0.71	314	142
14.00R24TG 2X AS-3A G3 TL	25.0	0.71	325	147
1400-20 24 UMS3A 6S NYTT	20.6	0.59	320	145
1400-20 24 WRL3A NYTT	20.6	0.59	317	144

Size/Type	Tire Cubeage		Tire Weight	
	Ft ³	M ³	Lbs	Kg
1400-20 24 WRL3A NYTT N0000	19.0	0.54	317	144
1400-20 24 WRL3A NYTTT/C60506	19.0	0.54	328	149
1400-20 28 UMS3A 6S TT	21.5	0.61	356	162
1400-20NHS 32 XTR3B AR NYTT	21.5	0.61	349	158
1400-20NHS 32 XTR3B AR NYTT N0000	21.5	0.61	349	158
1400-20NHS 48 XTR3B AR NYTT	21.5	0.61	435	197
1400-20NHS 48 XTR3B AR NYTT N0000	21.5	0.61	435	197
1400-24 10 SGG2A G2 NYTL	25.0	0.71	180	82
1400-24 10 SGG2A G2 NYTT	25.0	0.71	180	82
1400-24 12 SGG-4B NYTL	24.9	0.71	260	118
1400-24 12 SGG2A G2 TT	25.0	0.71	194	88
1400-24 12 SGG2A NYTL	25.0	0.71	177	80
1400-24 16 RKG3A NYTL	23.3	0.66	251	114
1400-24 16 SGG2A G2 4S TL	25.0	0.71	199	90
1400-24 16 SGG2A G2 TL	25.0	0.71	195	89
1400-24 16 SGG2A G2 TT	25.0	0.71	194	88
1400-24 20 HRL3A NYTT	26.6	0.75	293	133
1400-24 20 HRL3A NYTTT/C60506	23.6	0.67	303	138
1400-24 20 SMO-5B 6S NYTT	27.4	0.78	537	244
1400-24 24 WRL3A NYTT	23.5	0.66	344	156
1400-24 24 WRL3A NYTT N0000	22.0	0.62	344	156
1400-24 24 WRL3A NYTTT/C60506	22.0	0.62	355	161
1400-24 28 ELV3A INDUSTRIAL NY BSWTL	21.5	0.61	335	152
1400-24 28 UMS3A 6S NYTT	23.5	0.66	407	184
1400-24 28 WRL3A NYTT	23.5	0.66	366	166
1400-24 28 WRL3A NYTT N0000	22.0	0.62	366	166
1400-24 28 WRL3A NYTTT/C60506	22.0	0.62	377	171
1400-24NHS HRL-3A 24 PLY 4S E-3 BLT TT	25.0	0.71	336	152
1400-24NHS HRL-3A 28 PLY 4S E-3 BLT TT	25.0	0.71	336	152
1400-24TG 10 SGG2A G2 200 NYTL	25.0	0.71	180	82
1400-24TG 10 SGG2A G2 TL	25.0	0.71	194	88
1400-24TG 10 SGG2A G2 TT	25.0	0.71	194	88
1400-24TG 12 SGG2A G2 TL	25.0	0.71	194	88
1400-24TG 12 SGG2A G2 TT	25.0	0.71	194	88
1400-24TG 12 SGG2A G2 TT	25.0	0.71	206	93
1400-24TG 12 SGG2A NYTL DX	25.0	0.71	206	93
1400-24TG 12 SGG2A NYTT	25.0	0.71	194	88
1400-24TG 16 SGG2A G2 TL	25.0	0.71	194	88
1400-24TG 16 SGG2A G2 TT	25.0	0.71	194	88
1400-25 20 HRL3A NYTL	25.8	0.73	299	136
1400-25 20 HRL3A NYTLT/C60506	23.6	0.67	310	140
1400-25 20 HRR1A NYTL	24.8	0.70	283	128
1400-25NHS 24 EVL3A IND NYTL	25.7	0.73	300	136
1400R20 159G J AT2A TL	20.6	0.58	258	117
1400R20 J AT2A TL	21.3	0.60	268	121

APPROXIMATE SHIPPING DATA

Size/Type	Tire Cubeage		Tire Weight	
	Ft ³	M ³	Lbs	Kg
1400R20 J AT2A TLT/C60505	20.3	0.57	266	120
1400R20 M AT2A TL	20.6	0.58	263	119
1400R20 M AT2A TL 5E5250	20.6	0.58	263	119
1400R24 1X SG-2A TL	25.0	0.71	245	111
1400R24 1X SG-2B G-2 TL	23.6	0.67	282	128
1400R24 3X EV-4A INDUSTRIAL 24/24 6S TT	25.0	0.71	500	227
1400R24 3X EV4A 4S NYTT	25.0	0.71	500	227
1400R24 3X EV4M TT	26.2	0.74	435	197
1400R24 3X EV4M TT N0000	25.9	0.73	435	197
1400R24 3X EV4S TT	27.7	0.79	516	234
1400R24 3X RL-5K 08/08 L5 6S TL	25.0	0.71	316	143
1400R24 3X RL2F E2 4S TT	25.1	0.71	358	162
1400R24 3X RL4J E4 4S TT	27.4	0.78	509	231
1400R24 3X RL4J E4 4S TTTT D4217	27.4	0.78	509	231
1400R24 3X RL4L E4 4S TT	26.2	0.74	403	183
1400R24 3X UNISTEEL EV-4A 24/24 TL	25.0	0.71	411	186
1400R24NHS 3X RL-5K 12/12 L5 6S TL	25.0	0.71	600	272
1400R24NHS 3X RL-5K 24/24 L5 6S TL	25.0	0.71	567	257
1400R24NHS 3X RL-5S L5S 6S TL	25.0	0.71	316	143
1400R24TG 153A8 1X SG-2B G-2 TL	25.0	0.71	266	121
1400R24TG 153A8 1X SG-2B G-2 TL 038049	25.0	0.71	266	121
1400R24TG 153A8 1X SG2B G2 6S RPTL	25.0	0.71	266	121
1400R25 3X 170E AS3A E3 TL	25.7	0.73	471	214
1400R25 3X RL4J E4 2S TL	25.7	0.73	465	211
1400R25 3X RL4J E4 2S TL 8E5230	25.7	0.73	465	211
1400R25 3X RL4J E4 4S TL	27.4	0.78	501	227
1400R25 3X RL4J E4 4S TL D5078	27.4	0.78	501	227
1400R25NHS 3X RL-4L E-4 2S TL	25.7	0.73	372	169
155-25 08 SGLDL2A NYTL	22.2	0.63	169	77
155-25 12 HRLDL3A NYTL	22.9	0.65	219	99
155-25 12 SGLDL2A 100 TL	23.6	0.67	188	85
155-25 12 SGLDL2A NYTL	23.6	0.67	177	80
155R25 1X GP2B 6S TL	22.8	0.65	269	122
155R25 1X RL2F L2 6S TL	22.8	0.65	252	114
1600-20 16 SRB 7A 4S NYTT	26.7	0.76	217	98
1600-24 12 PVG 7A 4S NYTL	41.1	1.16	288	130
1600-24 16 SGG2A 4S NYTL	30.8	0.87	331	150
1600-25 24 HRL3A 6S TL	35.3	1.00	450	204
1600-25 28 ELV-3A 4S TL NGT 71720179	35.3	1.00	683	310
1600-25 28 ELV3C IND 2S TL	35.3	1.00	491	223
1600-25 28 ELV3C IND 4S TL	35.3	1.00	491	223
1600-25 28 HRL3A 100 4S NYTL	35.3	1.00	504	229
1600-25 28 HRL3A 200 4S NYTL	35.3	1.00	491	223
1600-25 28 HRL4B 4S NYTL	35.7	1.01	598	271
1600-25 32 ELV-3A IND 4S TL	35.3	1.00	683	310

Size/Type	Tire Cubeage		Tire Weight	
	Ft ³	M ³	Lbs	Kg
1600-25 32 ELV-3A IND 6S TL	35.3	1.00	683	310
1600-25 32 ELV3C IND 2S TL	35.3	1.00	491	223
1600-25 32 ELV4/5A NYTL	36.1	1.02	683	310
1600-25 32 HR RIB 4S NYTL	31.7	0.90	498	226
1600-25 32 HRL E3 4S TL	35.3	1.00	529	240
1600-25 32 HRL4B E4 2S NYTL	35.3	1.00	683	310
1600-25 32 HRL4B E4 3S NYTL	35.3	1.00	643	292
1600R20 M AT2A TL	26.9	0.76	333	151
1600R20 M AT2A TT	26.7	0.76	324	147
1600R20 M AT3A P9E5110 TL	26.7	0.76	352	160
1600R20 M AT3A TL	26.7	0.76	352	160
1600R20 M GP-AT TL	26.7	0.76	344	156
1600R20 M XE001MIL TL 5E5020	26.7	0.76	325	147
1600R20 M XE001MIL TL 5E5021	26.7	0.76	325	147
1600R21 M AT2A TL	26.9	0.76	336	152
1600R24 1X RL 2F G2 4S TL	33.4	0.95	365	165
1600R24 1X SG2B 4S TL	32.1	0.91	362	164
1600R25 198/A2 3X EV4K 00/12 TL	35.3	1.00	720	327
1600R25 198/A2 3X EV4K 12/12 IND4 TL	35.3	1.00	720	327
1600R25 2X RL3+ E3 4S TL	34.8	0.98	661	300
1600R25 2X RL3+ E3 4S TL D4901	34.8	0.98	661	300
1600R25 2X RL3+ E3 4S TL D4993	34.8	0.98	661	300
1600R25 3X EV-4A 24/24 TL	35.3	1.00	699	317
1600R25 3X EV-4A 24/24 TL	35.3	1.00	749	340
1600R25 3X EV-4C TL	35.3	1.00	749	340
1600R25 3X EV-4R TL	35.3	1.00	749	340
1600R25 3X EV-4S 00/00 TL	35.3	1.00	753	342
1600R25 3X EV4A 00/12 NYTL	35.3	1.00	736	334
1600R25 3X EV4A 00/12 NYTL	35.3	1.00	736	334
1600R25 3X EV4A IND 197A2 P8E5010 TL	35.3	1.00	711	323
1600R25 3X EV4S TL	36.9	1.05	718	326
1600R25 3X EV5S 00/00 4S TL	35.3	1.00	600	272
1600R25 3X UNISTEEL EV3+ IND TL	35.3	1.00	600	272
1600R25 3X UNISTEEL EV4A 00/12 TL	35.3	1.00	715	324
17.5-25 36 SM-3A BP TL	29.6	0.84	719	326
175-25 12 GRL D/L-3A L3/G3 TL	29.6	0.84	245	111
175-25 12 HRLDL3A 4S NYTL	29.6	0.84	281	128
175-25 12 SGLDL2A NYTL	29.6	0.84	217	98
175-25 16 GRL D/L-3A L3/G3 TL	29.6	0.84	254	115
175-25 16 HRLDL3A NYTL	29.8	0.84	308	140
175-25 16 SG LOAD NYTL	29.6	0.84	272	124
175-25 16 SGLDL2A NYTL	29.6	0.84	254	115
175-25 20 GRL D/L-3A L3/G3 TL	29.6	0.84	272	124
175-25 20 HRLDL3A 6S NYTL	29.6	0.84	423	192
175-25 20 SGLDL2A NYTL	29.6	0.84	269	122

APPROXIMATE SHIPPING DATA

Size/Type	Tire Cubeage		Tire Weight	
	Ft ³	M ³	Lbs	Kg
175-25 20 SMODL5B 6S NYTL	29.8	0.84	660	299
175-25 20 SMODL5C L5S6S TL	29.6	0.84	719	326
175-25 20 UMSDL3A 6S NYTL	29.8	0.84	438	199
175R25 167B 2X RL2+ 4S TL	29.6	0.84	370	168
175R25 167B 2X RL2+ 6S TL	29.6	0.84	370	168
175R25 167B 2X RL2+ E2 4S TL	29.6	0.84	370	168
175R25 167B 2X RL2+ E2 6S TL	29.6	0.84	370	168
175R25 176A2 1X RL2+ 4S TL	29.6	0.84	370	168
175R25 176A2 1X RL2+ 6S TL	29.6	0.84	370	168
175R25 176A2 1X RL2+ L2 6S TL	30.0	0.85	395	179
175R25 176A2 1X RT-3B 4S TL	29.6	0.84	370	168
175R25 176A2 1X RT-3B 6S TL	29.6	0.84	370	168
175R25 176A2 1X STONE GARD RT-3B 6S TL	29.6	0.84	417	189
175R25 1X AT2A TL	28.1	0.80	328	149
175R25 1X GP2B 6S TL	28.4	0.81	347	158
175R25 1X SG-2B TL	28.4	0.81	332	151
175R25 2X AS3A L3/G3 4S TL	29.6	0.84	367	166
175R25 2X RL-4K 12/12 E-4 6S TL	29.6	0.84	641	291
175R25 2X RL-4K HI-STABILITY 12/12 TL	29.6	0.84	641	291
175R25 2X RL-4K HI-STABILITY 24/24 TL	29.6	0.84	641	291
175R25 2X RL-5K 12/12 L5 6S TL	29.6	0.84	641	291
175R25 2X RL-5K HI-STABILITY 00/24 TL	29.6	0.84	641	291
175R25 2X RL-5K HI-STABILITY 12/12 TL	29.6	0.84	641	291
175R25 2X RL-5K HI-STABILITY 24/24 TL	29.6	0.84	626	284
175R25 2X RL-5S 00/00 L5S 6S TL	29.6	0.84	316	143
175R25 2X RL-5S HI-STABILITY TL	29.6	0.84	316	143
175R25 3X RL-5K 12/12 L5 6S TL	29.6	0.84	641	291
175R25 3X RL-5S 00/00 L5S 6S TL	29.6	0.84	660	300
175R25 3X UNISTEEL RL2+ L2/E2 4S TL	29.6	0.84	653	296
175R25 3X UNISTEEL RL2+ L2/E2 6S TL	29.6	0.84	653	296
175R25 RL3J C1 1*+2* 4S L-3/E-3/G-3 TL	29.6	0.84	370	168
175R25 RL3J C1 1*+2* 6S L-3/E-3/G-3 TL	29.6	0.84	370	168
175R25 TL3A+ C1 1*+2* 6S L-3+T/E-3+T TL	29.6	0.84	818	371
18.00-25 ELV-3A INDUSTRIAL BLT 6S BP TL	47.6	1.35	688	312
18.00R25 EV-5K INDUSTRIAL 24/24 3X TL	47.6	1.35	837	379
18.00R33 RL-3+ 3X TL 6S E-3	60.1	1.70	1126	511
1800-25 16 HRL3A 6S NYTL	47.6	1.35	822	373
1800-25 16 SRB 7A 4S NYTL	44.1	1.25	369	167
1800-25 24 SMO 5D L5S 6J TL	47.6	1.35	1026	465
1800-25 24 SMO5D L5S 6U NYTL	47.6	1.35	1052	477
1800-25 28 ELV-3A NYTL	47.2	1.34	665	302
1800-25 28 SMO 5D 6S NYTL	51.3	1.45	1214	550
1800-25 28 SMO 5D L5S 6J TL	47.6	1.35	1026	465
1800-25 28 SMO5D L5S 6U NYTL	47.6	1.35	1052	477
1800-25 28 SMO5D L5S 6U TL	47.6	1.35	1052	477

Size/Type	Tire Cubeage		Tire Weight	
	Ft ³	M ³	Lbs	Kg
1800-25 28 SMO5E L5S 6S NYTL	47.6	1.35	1050	476
1800-25 28 SMO5E L5S 6S NYTL	47.6	1.35	1021	463
1800-25 32 ELV3A IND 4S TL	47.6	1.35	688	312
1800-25 32 HRL3A E3 4S TL	47.6	1.35	881	400
1800-25 32 SMO5D L5S 6U NYTL	47.6	1.35	1052	477
1800-25 36 ELV-3A IND 6S TL	47.6	1.35	1052	477
1800-25 36 ELV3A IND 4S TL	47.6	1.35	977	443
1800-25 36 HRL3A E3 4S TL	47.6	1.35	977	443
1800-25 40 ELV-3A NYTL	47.6	1.35	665	302
1800-25 40 ELV3A IND 4S TL	47.6	1.35	688	312
1800-25 40 ELV4B IND 6S TL	47.6	1.35	688	312
1800-25 40 ELV4B NYTL	46.9	1.33	926	420
1800-25 40 ELV4B NYTL	47.6	1.35	926	420
1800-25 40 ELV4C 2S NYTL	47.6	1.35	993	450
1800-25 40 ELV4D IND 2S TL	47.6	1.35	929	421
1800-25 40 ELV4D IND 4S TL	47.6	1.35	1144	519
1800-25 40 ELV5D IND 2S TL	47.6	1.35	929	421
1800-25 40 ELV5D IND 4S TL	47.6	1.35	929	421
1800-25 40 ELV5D IND 5S TL	47.6	1.35	929	421
1800-25 40 ELV5D TL	50.5	1.43	1208	548
1800-25 40 ELV5E IND5 NYTL	47.6	1.35	1140	517
1800-33 32 HRL3A E3 4S TL	60.1	1.70	836	379
1800-33 32 HRL3A E3 6S TL	60.1	1.70	836	379
1800-33 32 HRL4B 4S NYTL	60.1	1.70	955	433
1800-33 36 ELV4B IND 4S TL	60.1	1.70	836	379
1800-33 36 ELV4B IND 6S NYTL	60.1	1.70	1112	505
1800-33 36 ELV4B NYTL	60.1	1.70	1032	468
1800-33 36 HRL3A E3 4S TL	60.1	1.70	836	379
1800-33 36 HRL3A E3 4S TL	60.1	1.70	836	379
1800-33 36 HRL4B 6S NYTL	60.1	1.70	972	441
1800-33 36 HRL4B 6S NYTT	60.1	1.70	972	441
1800-33 36 HRL4B E4 4S TL	60.1	1.70	836	379
1800-33 36 HRL4B E4 6S TL	60.1	1.70	836	379
1800R25 2X RL-5S L5 6S TL	47.6	1.35	1183	537
1800R25 2X RL3+ E3 2S TL	47.1	1.33	736	334
1800R25 2X RL3+ E3 2S TL D4486	47.1	1.33	736	334
1800R25 2X RL3+ E3 2S TL D5874	47.1	1.33	736	334
1800R25 2X RL3+ E3 2S TL D6245	47.1	1.33	736	334
1800R25 2X RL3+ E3 4S TL	47.1	1.33	737	334
1800R25 2X RL4 E4 6S TL	47.6	1.35	120	54
1800R25 2X RL4B E4 4S TL	49.0	1.39	779	353
1800R25 2X RL4B E4 6S TL	49.0	1.39	783	355
1800R25 2X RL4J E4 4S TL	50.2	1.42	777	352
1800R25 2X RL4J E4 6S TL	50.2	1.42	782	355
1800R25 2X RL5K L5 4S TL	47.6	1.35	750	340

APPROXIMATE SHIPPING DATA

Size/Type	Tire Cubeage		Tire Weight	
	Ft ³	M ³	Lbs	Kg
1800R25 2X RL5K L5 6S TL	50.6	1.43	1059	480
1800R25 2X RL5K L5 6S TL 00028	50.6	1.43	1059	480
1800R25 2X RL5K L5 6S TL D5751	50.6	1.43	1059	480
1800R25 2X SM5A L5S6S TL	47.6	1.35	1102	500
1800R25 2X SM5A L5S6S TLSO D5055	47.6	1.35	1102	500
1800R25 3X EV-4S TL	55.3	1.57	1068	484
1800R25 3X EV3+ TL	47.1	1.33	895	406
1800R25 3X EV4K 08/08 TL	47.6	1.35	837	379
1800R25 3X EV4K TL	55.3	1.57	988	448
1800R25 3X EV5S 4S TL	55.3	1.57	1135	515
1800R25 3X EV5S IND5 TL	47.6	1.35	1191	540
1800R25 3X EV5S TL	47.6	1.35	1198	543
1800R25 3X RL-5S L5 6S TL	47.6	1.35	1248	566
1800R33 211A2 3X EV-4J INDUSTRIAL TL	60.1	1.70	1327	602
1800R33 2X RL3+ E3 2S TL	58.2	1.65	992	450
1800R33 2X RL4B E4 4S TL	58.2	1.65	966	438
1800R33 2X RL4B E4 6S TL	58.2	1.65	975	442
1800R33 2X RL4J E4 4S TL	61.9	1.75	1015	460
1800R33 2X RT4A E4 2S TL	60.1	1.70	1004	455
1800R33 2X RT4A E4 4S TL	60.1	1.70	1005	456
1800R33 2X RT4A E4 6S TL	60.1	1.70	1010	458
1800R33 3X EV-S4S IND 4 TL	60.1	1.70	1252	568
1800R33 3X EV-S5S IND TL	60.1	1.70	837	379
1800R33 3X EV3+ TL	58.2	1.65	1128	512
1800R33 3X EV4S TL	60.1	1.70	837	379
1800R33 3X RL3+ E3 4S TL	60.1	1.70	1126	511
1800R33 3X RL4B E4 4S TL	60.1	1.70	985	447
1800R33 RL-4J 3X E-4 2S 195B TL	60.1	1.70	1056	479
1800R33 RL-4J 3X E-4 4S 195B TL	60.1	1.70	1056	479
1800R33 RL-4J 3X E-4 6S 195B TL	60.1	1.70	1056	479
1800R33 RT-4A 3X E-4 2S 195B TL	60.1	1.70	1056	479
1800R33 RT-4A 3X E-4 4S 195B TL	60.1	1.70	1056	479
1800R33 RT-4A 3X E-4 6S 195B TL	60.1	1.70	1056	479
195R25 2X RL-5K 24/24 L5 6S 216A2 TL	95.3	2.70	2049	929
20.5R25 C1 GP4D 6S L-4/E-4 TL	42.5	1.20	1569	712
20.5R25 RL-2+ 2X E-2 4S TL	42.5	1.20	840	381
20.5R25 RL-4K 2X 6S TL	42.5	1.20	840	381
20.5R25 RL-5K HI-STABILITY L5 6S 00/24	42.5	1.20	818	371
205-25 12 GRL DL-3A L3/E3/G3 4S TL	42.5	1.20	355	161
205-25 12 HRL3A 6S NYTT	42.5	1.20	369	167
205-25 12 HRLEL3A 4S NYTL	42.5	1.20	401	182
205-25 12 SGLEL2A 4S NYTL	42.5	1.20	360	163
205-25 16 GRL DL-3A L3/E3/G3 4S TL	42.5	1.20	367	167
205-25 16 HRL 3A BRZ TL	42.5	1.20	399	181
205-25 16 HRLEL3A 100 4S NYTL	42.5	1.20	476	216

Size/Type	Tire Cubeage		Tire Weight	
	Ft ³	M ³	Lbs	Kg
205-25 16 HRLEL3A 200 4S NYTL	42.5	1.20	476	216
205-25 16 HRLEL3A L3/E3/G3 4S TL	42.5	1.20	476	216
205-25 16 HRLEL3A L3/E3/G3 4S TT	42.5	1.20	476	216
205-25 16 HRLEL3A L3/E3/G3 6S TL	42.5	1.20	476	216
205-25 16 HRLEL3A L3/E3/G3 6S TT	42.5	1.20	476	216
205-25 16 SGLEL2A 4S NYTL	42.5	1.20	389	177
205-25 16 SGLEL2A 4S NYTLDX	44.1	1.25	399	181
205-25 20 HRLEL3A 100 4S NYTL	42.5	1.20	399	181
205-25 20 HRLEL3A 4S NYTL	44.2	1.25	511	232
205-25 HRL E/L-3A 4S	42.5	1.20	399	181
205-25 HRL E/L-3A 4S	42.5	1.20	399	181
205R25 177B 2X RL2+ 4S TL	42.5	1.20	650	295
205R25 177B 2X RL2+ E2 4S TL	41.6	1.18	573	260
205R25 177B 2X STNGRD RT3B E3 4S TL	42.5	1.20	524	238
205R25 177B 2X STNGRD RT3B E3 6S TL	42.5	1.20	650	295
205R25 186/A2 1X STNGRD RT3B L3 3 6S TL	42.5	1.20	559	254
205R25 186A2 1X RL2+ 6S TL	42.5	1.20	650	295
205R25 186A2 1X RL2+ 6S TL	42.5	1.20	650	295
205R25 186A2 1X RL2+ L2 6S TL	41.6	1.18	541	245
205R25 186A2 1X RT-3B 6S TL	42.5	1.20	559	254
205R25 186A2 1X STNGRD RT3B 6S TL	42.5	1.20	562	255
205R25 186A2 1X STNGRD RT3B L3/G 4S TL	42.5	1.20	554	251
205R25 186A2 3X RL2+ L2/E2 6S TL	42.5	1.20	651	295
205R25 1X GP2B 6S TL	40.8	1.16	495	225
205R25 1X GP4B AT 6S TL	42.5	1.20	595	270
205R25 1X RL-5K 24/24 L5 6S TL	46.0	1.30	789	358
205R25 1X TL3A+ 6S L3 TL	42.5	1.20	818	371
205R25 1X UNISTEEL TL-3A+ 6S TL	42.5	1.20	650	295
205R25 2X GP2B 4S TL	40.8	1.16	481	218
205R25 2X RL-3S HI-STABILITY 6S L-3S	42.5	1.20	818	371
205R25 2X RL-4K HI-STABILITY 24/24	42.5	1.20	818	371
205R25 2X RL-5K 24/24 L5 4S RPTL	46.0	1.30	797	361
205R25 2X RL-5K HI-STABILITY 24/24	42.5	1.20	818	371
205R25 2X RL-5K L5 6S TL	42.5	1.20	840	381
205R25 2X RL-5S HI-STABILITY 6S L5S	42.5	1.20	818	371
205R25 2X RL2+ 6S TL	42.5	1.20	797	362
205R25 2X RL3S L3S 6S 193 A2 TL	42.5	1.20	818	371
205R25 2X RL5S L5S 6S TL	42.5	1.20	818	371
205R25 2X UNISTEEL TL-3A+ 4S TL	42.5	1.20	650	295
205R25 2X UNISTEEL TL-3A+ 6S TL	42.5	1.20	650	295
205R25 3X UNISTEEL RL2+ L2/E2 4S TL	42.5	1.20	650	295
205R25 RL-2+ 186A2 4S TL	42.5	1.20	527	239
205R25 RL-2+ 186A2 6S TL	42.5	1.20	527	239
205R25 RL3J C1 1*+2* 4S L-3/E-3/G-3 TL	42.5	1.20	650	295
205R25 RL3J C1 1*+2* 6S L-3/E-3/G-3 TL	42.5	1.20	650	295

APPROXIMATE SHIPPING DATA

Size/Type	Tire Cubeage		Tire Weight	
	Ft ³	M ³	Lbs	Kg
205R25 TL3A+ C1 1*+2* 4S L-3+T/E-3+T TL	42.5	1.20	818	371
205R25 TL3A+ C1 1*+2* 6S L-3+T/E-3+T TL	42.5	1.20	818	371
2100-25 16 SRB7A 2S NYTL	67.1	1.90	416	189
2100-25 28 SRB 7A 4S NYTL	63.5	1.80	510	231
2100-25 32 ELV 5A NYTL	62.8	1.78	1339	607
2100-25 32 ELV3A NYTL	63.5	1.80	938	426
2100-25 32 SMO5A 6S NYTL	62.8	1.78	1347	611
2100-25 32 SMO5C 6J NYTL	62.8	1.78	1702	772
2100-25 32 SMO5C 6S NYTL	62.8	1.78	1565	710
2100-25 32 SMO5C L5S 4S NYTL	63.5	1.80	1000	454
2100-25 32 SMO5C L5S 6S NYTL	63.5	1.80	1000	454
2100-25 36 ELV3A IND-3 TL	63.5	1.80	944	428
2100-35 36 HRL4B 4S NYTL	89.3	2.53	1312	595
2100-35 40 ELV-4B IND NYTL	83.0	2.35	1378	625
2100-35 40 ELV4B IND 4S TL	83.0	2.35	1378	625
2100-35 40 HRL4B 4S NYTL	83.0	2.35	1378	625
2100-35 40 HRL4B E4 6S TL	83.0	2.35	1378	625
2100-35 42 ELV4B NYTL	88.4	2.50	1567	711
2100R33 2X RL4B 2S TL	76.0	2.15	2326	1055
2100R33 2X RL4B E4 4S TL	76.0	2.15	1290	585
2100R33 2X RL4B E4 6S TL	76.0	2.15	2326	1055
2100R33 2X RL4B E4 6S TL	76.0	2.15	2326	1055
2100R35 2X RL3+ E3 2S TL	84.1	2.38	1305	592
2100R35 2X RL3+ E3 4S TL	84.1	2.38	1307	593
2100R35 2X RL4B E4 4S TL	88.2	2.50	1274	578
2100R35 2X RL4B E4 6S TL	88.2	2.50	1280	581
2100R35 2X RL4H2 2S TL	83.0	2.35	3088	1401
2100R35 2X RL4HII E4 4S TL	83.0	2.35	1423	646
2100R35 2X RL4HII E4 6H P0E7005 TL	83.0	2.35	3088	1401
2100R35 2X RL4HII E4 6H TL	83.0	2.35	3088	1401
2100R35 2X RL4J E4 2S TL	86.8	2.46	1364	619
2100R35 2X RL4J E4 2S TL D6121	86.8	2.46	1364	619
2100R35 2X RL4J E4 6S TL	86.8	2.46	1375	624
2100R35 2X RL4J E4 6S TL	86.8	2.46	1375	624
22/65R25 1X AT2A TL	37.0	1.05	415	188
23.5R25 RL-2+ 2X E-2 4S TL	57.1	1.62	837	379
23.5R25 RL-2+ C1 1*+2* 4S L-2/E-2/G-2	57.1	1.62	679	308
23.5R25 RL-2+ C1 1*+2* 6S L-2/E-2/G-2	57.1	1.62	679	308
23.5R25 RL-3J 4S C1 1*+2* L-3/E-3 TL	57.1	1.62	807	366
23.5R25 RL-3J 6S C1 1*+2* L-3/E-3 TL	57.1	1.62	807	366
23.5R25 RL-5S 2X BLT 6S TL	57.1	1.62	1475	669
23/90-25 30 SMO5C 6S NYTL	56.6	1.60	1227	557
23/90-25 30 SMO5D L5S 6U TL	58.7	1.66	1199	544
235-25 12 HRL3A 6S NYTL	57.1	1.62	503	228
235-25 16 HRLEL3A 100 4S NYTL	57.1	1.62	635	288

Size/Type	Tire Cubeage		Tire Weight	
	Ft ³	M ³	Lbs	Kg
235-25 16 HRLEL3A 200 4S NYTL	57.1	1.62	572	259
235-25 16 HRLEL3A L3/E3/G3 4S TT	57.1	1.62	541	246
235-25 16 HRLEL3A L3/E3/G3 6S TL	57.1	1.62	541	246
235-25 16 HRLEL3A L3/E3/G3 6S TT	57.1	1.62	541	246
235-25 16 SGLEL2A 100 4S NYTL	57.1	1.62	543	246
235-25 20 GGL D/L 2A 4S TL	57.1	1.62	492	223
235-25 20 GRL D/L 3A 4S TL	57.1	1.62	598	271
235-25 20 HRLEL3A 100 4S NYTL	57.1	1.62	633	287
235-25 20 HRLEL3A 200 4S NYTL	57.1	1.62	633	287
235-25 20 HRLEL3A 4S NYTL	56.6	1.60	633	287
235-25 20 HRLEL3A L3/E3/G3 6S NYTL	57.1	1.62	1001	454
235-25 20 SGLEL2A L2/E2/G2 4S TL	57.1	1.62	541	246
235-25 HRL E/L3A 4S L-3/E-3/G-3	57.1	1.62	633	287
235-25 HRL E/L3A 4S L-3/E-3/G-3	57.1	1.62	633	287
235R25 185/B 2X RT-3B E3 4S TL	57.1	1.62	752	341
235R25 185/B 2X STNGRD RT3B E3 4S TL	57.1	1.62	752	341
235R25 185B 2X TL3A+ E3 4S TL	57.1	1.62	678	307
235R25 185B 2X TL3A+ E3 6S TL	57.1	1.62	678	307
235R25 195/A2 1X RT-3B L3/G3 6S TL	57.1	1.62	743	337
235R25 195/A2 1X STNGRD RT3B L3 3 6S TL	57.1	1.62	745	338
235R25 195A2 1X RL2+ 6S TL	57.1	1.62	807	366
235R25 195A2 1X TL3A+ L3 4S TL	57.1	1.62	678	307
235R25 195A2 1X TL3A+ L3 6S TL	57.1	1.62	678	307
235R25 1X GP4B AT 6S TL	57.9	1.64	819	372
235R25 1X GP4C 4S TL	57.1	1.62	872	396
235R25 1X RL-5K 24/24 L5 6S TL	60.1	1.70	1034	469
235R25 1X RL5K L5 6S TL	60.1	1.70	1115	506
235R25 1X TL3A+ 6S TL	57.1	1.62	690	313
235R25 1X UE47XT L4 6S TL	57.1	1.62	800	363
235R25 1X UNISTEEL RT5C L5 6S TL	57.1	1.62	999	453
235R25 201A2 2X RL2+ L2 6S TL	57.1	1.62	791	359
235R25 201A2 2X UNISTEEL RT5C L5 6S TL	57.1	1.62	1078	489
235R25 2X GP4B AT 4S TL	57.9	1.64	690	313
235R25 2X GP4B AT 6S TL	57.1	1.62	690	313
235R25 2X GP4C 2S E-4 TL	57.1	1.62	872	396
235R25 2X GP4C 4S E-4 TL	57.1	1.62	872	396
235R25 2X GP4C 6S E-4 TL	57.1	1.62	872	396
235R25 2X RL-4K 24/24 6S TL	57.1	1.62	1105	501
235R25 2X RL-4S 6S TL	57.1	1.62	1105	501
235R25 2X RL-5K 00/24 L5 6S TL	57.1	1.62	815	370
235R25 2X RL-5K 24/24 L5 4S TL	60.1	1.70	815	370
235R25 2X RL-5K HI-STABILITY L5 6S 24/24	57.1	1.62	1034	469
235R25 2X RL2+ 4S TL	57.1	1.62	807	366
235R25 2X RL2+ E2 4S TL	57.2	1.62	793	360
235R25 2X RL2+ E2 6S TL	57.1	1.62	791	359

APPROXIMATE SHIPPING DATA

Size/Type	Tire Cubeage		Tire Weight	
	Ft ³	M ³	Lbs	Kg
235R25 2X RL2+ L2 6S TL	57.1	1.62	791	359
235R25 2X RL3S 201A2 6S TL	57.1	1.62	807	366
235R25 2X RL3S HI-STABILITY L3S 6S TL	57.1	1.62	1120	508
235R25 2X RL4K HI-STABILITY L4 6S 24/24	57.1	1.62	1120	508
235R25 2X RL4S HI-STABILITY L4S 6S TL	57.1	1.62	1120	508
235R25 2X RL5K HI-STABILITY L5 6S 00/24	57.1	1.62	1120	508
235R25 2X RL5K HI-STABILITY L5S 6S 24/24	57.1	1.62	1120	508
235R25 2X RL5K L5 6S TL	57.1	1.62	1475	669
235R25 2X RL5S HI-STABILITY L5S 6S TL	57.1	1.62	1120	508
235R25 2X TL3A+ 4S TL	57.1	1.62	690	313
235R25 2X TL3A+ 6S C1 TL	57.1	1.62	690	313
235R25 2X TL3A+ 6S TL	57.1	1.62	690	313
235R25 3X UNISTEEL RL2+ L2/E2 4S TL	57.1	1.62	837	379
235R25 3X UNISTEEL RL2+ L2/E2 6S TL	57.1	1.62	837	379
235R25 GP-4C 2S C1 1*+2* L-4/E-4 TL	57.1	1.62	807	366
235R25 GP-4C 4S C1 1*+2* L-4/E-4 TL	57.1	1.62	807	366
235R25 GP-4C 6S C1 1*+2* L-4/E-4 TL	57.1	1.62	807	366
235R25 GP-4D 6S C1 1STAR+2STARL-4/E-4 TL	57.1	1.62	807	366
235R25 RL-2+ 4S C1 1*+2* L-3+T/E-3+T TL	57.1	1.62	807	366
235R25 RL-2+ 6S C1 1STAR+2STAR 3+T TL	57.1	1.62	807	366
235R25 TL3A+ C1 1*+2* 4S L-3+T/E-3+T TL	57.1	1.62	679	308
235R25 UNISTEEL RL-2+ 6H 2* 201A2 TL	57.1	1.62	837	379
24-1200-12 24 XTR3B AR NYTL	4.0	0.11	77	35
24-1200-12 24 XTR3B AR NYTL N0000	3.9	0.11	77	35
24-21 14 SRB7A 2S NYTL	42.1	1.19	280	127
2400-35 36 HRL3A E3 4S NYTL	106.7	3.02	1609	730
2400-35 36 HRL4B E4 4S NYTL	106.7	3.02	1609	730
2400-35 36 MRL4B 4S NYTL	106.7	3.02	1609	730
2400-35 42 HRL4B E4 2S NYTL	106.7	3.02	1678	761
2400-35 42 HRL4B E4 4S NYTL	106.7	3.02	1609	730
2400-35 42 MRL4B E4 4S NYTL	106.7	3.02	1678	761
2400-35 48 HRL4B E4 4S NYTL	106.7	3.02	1609	730
2400-49 48 HRL4B 4S NYTL	144.9	4.10	2347	1065
2400R35 209B 2X RT-4A+ E4 6S TL	106.7	3.02	1677	761
2400R35 2X RL3+ E3 2S TL	105.8	3.00	1619	734
2400R35 2X RL3+ E3 2S TL SO D5063	105.8	3.00	1619	734
2400R35 2X RL3+ E3 4S TL	105.8	3.00	1621	735
2400R35 2X RL4B E4 2S TL	106.7	3.02	1685	764
2400R35 2X RL4B E4 4S TL	81.5	2.31	1680	762
2400R35 2X RL4B E4 6S TL	81.5	2.31	1697	770
2400R35 2X RL4HII E4 5S TL	106.7	3.02	1423	646
2400R35 2X RL4J E4 2S TL	106.7	3.02	1685	764
2400R35 2X RL4J E4 4S TL	117.0	3.31	1687	765
2400R35 2X RL4J E4 4S TL	106.7	3.02	1687	765
2400R35 2X RL4J E4 4S TL D5997	117.0	3.31	1687	765

Size/Type	Tire Cubeage		Tire Weight	
	Ft ³	M ³	Lbs	Kg
2400R35 2X RL4J E4 6S TL	117.0	3.31	1703	773
2400R35 2X RL4JII E4 2S TL	106.7	3.02	1707	774
2400R35 2X RL4JII E4 4S TL	106.7	3.02	1707	774
2400R35 2X RL4JII E4 6S TL	106.7	3.02	1707	774
2400R35 2X RT-4A+ E4 2S TL	106.7	3.02	1677	761
2400R35 2X RT-4A+ E4 4S TL	106.7	3.02	1721	780
2400R35 2X RT-4A+ E4 6S TL	106.7	3.02	1730	785
2400R49 2X RL3+ E3 4S TL	144.9	4.10	2342	1062
2400R49 2X RL3+ E3 6S TL	144.9	4.10	1671	758
2400R49 2X RL4 E4 2S TL	153.7	4.35	2325	1055
2400R49 2X RL4 E4 4S TL	153.7	4.35	2328	1056
26.5R25 GP-4D C1*+2* L-4/E-4 6S TL	74.8	2.12	1198	543
26.5R25 RL-2+ 2X E-2 4S TL	74.8	2.12	1104	501
26.5R25 RL-3S HI-STABILITY 2X TL 6S	74.8	2.12	1332	604
26.5R25 RL-4K HI-STABILITY 24/24 2* 6S	74.8	2.12	1332	604
26.5R25 RL-4S HI-STABILITY 2X TL 6S	74.8	2.12	1332	604
26.5R25 RL-5S HI-STABILITY 2X TL 6S	74.8	2.12	1332	604
26.5R25RL-4K HI-STABILITY 23/23 2X TL 6S	74.8	2.12	1332	604
26.5R25RL-5K HI-STABILITY 00/23 2X TL 6S	74.8	2.12	1332	604
26.5R25RL-5K HI-STABILITY 23/23 2X TL 6S	74.8	2.12	1332	604
265-25 14 SG LUG DL 4S NYTL	73.6	2.08	650	295
265-25 20 HRL3A E3 4S NYTL	74.8	2.12	928	421
265-25 20 HRLDL3A 4S NYTL	74.8	2.12	928	421
265-25 20 HRLDL3A L3 4S NYTL	74.8	2.12	1042	473
265-25 20 SG LUG DL 4S NYTL	73.6	2.08	752	341
265-25 20 SXT DL 4S NYTL	80.8	2.29	1313	595
265-25 24 HRL3A 4S NYTL	74.8	2.12	1119	508
265-25 24 HRLDL3A L3 4S NYTL	74.8	2.12	928	421
265-25 24 HRLDL3A L3 6S NYTL	74.8	2.12	928	421
265-25 24 SHRL DL 4S NYTL	74.8	2.12	990	449
265-25 24 SHRLXTDL4S NYTL	79.9	2.26	1119	508
265-25 26 GRL D/L-3A 4S NYTL	74.8	2.12	820	372
265-25 26 HRLDL3A L3 4S TL	74.8	2.12	489	222
265-25 26 SHRL 2S NYTL	74.7	2.12	904	410
265-25 26 SMODL5C 6S NYTL	79.9	2.26	1668	757
265-25 26 SMODL5C L5S 6S TL	74.8	2.12	1736	788
265-25 32 SMO5C 4J NYTL	74.8	2.12	1231	558
265-25 32 SMODL5C 6J NYTL	74.8	2.12	1863	845
265-25 32 SMODL5C 6S NYTL	79.9	2.26	1734	787
265-25 32 SMODL5C L5S 2S TL	74.8	2.12	1736	788
265-25 32 SMODL5C L5S 6J TL	74.8	2.12	1736	788
265-25 32 SMODL5C L5S 6S TL	74.8	2.12	1736	788
265-25 32 SMODL5C L5S 6U TL	74.8	2.12	1736	788
265-25 32 SXT DL 4S NYTL	80.8	2.29	1479	671
265-25 36 SMODL5C L5S 6J TL	74.8	2.12	1736	788

APPROXIMATE SHIPPING DATA

Size/Type	Tire Cubeage		Tire Weight	
	Ft ³	M ³	Lbs	Kg
265-29 26 HRL-3A 4S NYTL	83.6	2.37	956	434
265R25 193B 2X STNGRD RT3B E3 4S TL	74.8	2.12	974	442
265R25 193B 2X STNGRD RT3B E3 6S TL	74.8	2.12	974	442
265R25 193B 2X TL-3A+ 4S E3+ TL	74.8	2.12	1147	520
265R25 1X GP2B 6S TL	72.6	2.06	956	434
265R25 1X GP4B AT 6S TL	73.6	2.08	1068	484
265R25 1X RL-4K 24/24 L4 6S TL	73.6	2.08	1294	587
265R25 1X RL2+ L2 6S TL	74.8	2.12	1101	499
265R25 1X RL5K L5 6S TL	79.0	2.24	1577	715
265R25 1X UNISTEEL RT5C L5 6S TL	74.8	2.12	1419	644
265R25 202/A2 1X RT3B L3/G3 6S TL	74.8	2.12	1054	478
265R25 202A2 1X TL-3A+ 6S L3 TL	74.8	2.12	1107	502
265R25 209/A2 2X STONE GARD RT L36STL	74.8	2.12	1152	523
265R25 209A2 2X RL3S 6S TL	74.8	2.12	1107	502
265R25 209A2 2X STNGRD RT3B L3/E3 6S TL	74.8	2.12	974	442
265R25 2X GP-4D 4S TL	74.8	2.12	1142	518
265R25 2X GP-4D 6S TL	74.8	2.12	1198	543
265R25 2X GP-4D E4 4S TL	74.8	2.12	973	442
265R25 2X GP-4D E4 6S TL	74.8	2.12	973	442
265R25 2X GP-4D E4 6W TL	74.8	2.12	973	442
265R25 2X GP2B 4S TL	72.6	2.06	961	436
265R25 2X GP4B AT 4S TL	73.6	2.08	1083	491
265R25 2X GP4B AT 6S TL	73.6	2.08	1088	494
265R25 2X GP4D 4S TL	74.8	2.12	1142	518
265R25 2X GP4D 6S TL	74.8	2.12	1198	543
265R25 2X RL-5K 24/24 L5 6S TL	74.8	2.12	1537	697
265R25 2X RL-5S L-5S 6S TL	74.8	2.12	720	327
265R25 2X RL2+ E2 4S TL	74.8	2.12	1104	501
265R25 2X RL2+ E2 6S TL	74.8	2.12	1200	544
265R25 2X RL2+ E2 6S TL	74.8	2.12	1200	544
265R25 2X RL4K 209A2 TL	74.8	2.12	720	327
265R25 2X RL4S 209A2 TL	74.8	2.12	720	327
265R25 2X RL5K 00/23 L5 6S TL	74.8	2.12	720	327
265R25 2X RL5K L5 4S TL	79.0	2.24	720	327
265R25 2X RL5K L5 4S TL D5836	79.0	2.24	720	327
265R25 2X RL5K L5 6S TL	74.8	2.12	1566	710
265R25 2X RL5K L5 6S TL D5127	74.8	2.12	1566	710
265R25 2X SM5A L5S6S TL	74.8	2.12	1764	800
265R25 2X SM5A L5S6S TL	74.8	2.12	1764	800
265R25 2X STNGRD RT3B 4S TL	74.8	2.12	952	432
265R25 2X STONEGARD RT3B L3/E3 6S TL	74.8	2.12	956	434
265R25 2X TL-3A+ 4S TL	74.8	2.12	1107	502
265R25 2X TL-3A+ 6S RP TL	74.8	2.12	1112	504
265R25 2X UNISTEEL RT5C L5 6S TL	74.8	2.12	1387	629
265R25 3X GP-4D E-4 4S TL	74.8	2.12	973	442

Size/Type	Tire Cubeage		Tire Weight	
	Ft ³	M ³	Lbs	Kg
265R25 3X GP-4D E-4 6S TL	74.8	2.12	973	442
265R25 3X RL-5S L-5S 6S 9E5011 TL	74.8	2.12	720	327
265R25 3X RL-5S L-5S 6S TL	74.8	2.12	720	327
265R25 C1 TL-3A+ 4S TL	74.8	2.12	1107	502
265R25 C1 TL-3A+ 6S TL	74.8	2.12	1112	504
265R25 GP-4D 2X L-4 4S TL	74.8	2.12	1142	518
265R25 GP-4D 2X L-4 6S TL	74.8	2.12	1142	518
265R25 TL-3A+ C1 1*+2* 4S L-3+T/E-3+T TL	74.8	2.12	1108	503
265R29 2X RL3S 6S TL	83.6	2.37	1041	472
265R29 2X RL3S HI-STABILITY 6S L-3S TL	83.6	2.37	1041	472
27-15-10 24 UMS3B NYTT	2.1	0.06	100	45
27-9-10NHS 16 UMS3B NYTT	3.5	0.10	73	33
2700-49 48 HRL4B 2S NYTL	186.2	5.27	3000	1361
2700-49 48 HRL4B E-4 TYPE 4S BSWTL	186.2	5.27	2966	1346
2700-49 48 MRL 4D 2S E-4 NYTL	186.2	5.27	3000	1361
2700-49 48 MRL 4D 4S NYTL	186.2	5.27	3000	1361
2700R49 123/B 2X RT-4A+ 3S TL	186.2	5.27	3063	1389
2700R49 223/B 2X RT4A+ E4 4S TL	186.2	5.27	3057	1387
2700R49 2X GB4B 3S TL	186.2	5.27	2374	1077
2700R49 2X GB4B 5S TL	186.2	5.27	2374	1077
2700R49 2X GP2B E2 2S TL	185.7	5.26	2326	1055
2700R49 2X GP4B E4 4H TL	186.2	5.27	3092	1402
2700R49 2X GP4B E4 6H TL	186.2	5.27	3092	1402
2700R49 2X GT-4B E-4 2S TL	186.2	5.27	2374	1077
2700R49 2X RL-4H ARCTIC E4 6S TL	186.2	5.27	3011	1366
2700R49 2X RL3+ E3 2S P5E7041 TL	186.2	5.27	2987	1355
2700R49 2X RL3+ E3 2S TL	186.2	5.27	2987	1355
2700R49 2X RL4 E4 2S TL	187.9	5.32	2968	1346
2700R49 2X RL4 E4 3S TL	186.2	5.27	2954	1340
2700R49 2X RL4 E4 3S TL D5941	186.2	5.27	2954	1340
2700R49 2X RL4 E4 4S TL	153.7	4.35	2973	1348
2700R49 2X RL4A E4 3H TL	186.2	5.27	2956	1341
2700R49 2X RL4B E4 2S TL	153.7	4.35	2911	1320
2700R49 2X RL4B E4 3S TL	186.2	5.27	2913	1321
2700R49 2X RL4B E4 4S TL	153.7	4.35	2915	1322
2700R49 2X RL4B E4 6S TL	153.7	4.35	2932	1330
2700R49 2X RL4H ARCTIC E4 4S TL	186.2	5.27	2990	1356
2700R49 2X RL4H E4 2S TL	193.6	5.48	2989	1356
2700R49 2X RL4H E4 3S TL	186.2	5.27	2956	1341
2700R49 2X RL4H E4 3S TL	186.2	5.27	2992	1357
2700R49 2X RL4H E4 4S TL	193.6	5.48	2994	1358
2700R49 2X RL4H E4 6S TL	193.6	5.48	3012	1366
2700R49 2X RL4H1 6H TL	186.2	5.27	2900	1315
2700R49 2X RL4J E4 3S TL	186.2	5.27	2945	1336
2700R49 2X RL4J E4 4S TL	193.6	5.48	2947	1337

APPROXIMATE SHIPPING DATA

Size/Type	Tire Cubeage		Tire Weight	
	Ft ³	M ³	Lbs	Kg
2700R49 2X RL4J E4 6S TL	193.6	5.48	2965	1345
2700R49 2X RL4JII E4 2S TL	193.6	5.48	2943	1335
2700R49 2X RL4JII E4 2S TL D5457	193.6	5.48	2943	1335
2700R49 2X RL4JII E4 3S TL	186.2	5.27	2945	1336
2700R49 2X RL4JII E4 4S TL	193.6	5.48	2947	1337
2700R49 2X RL4JII E4 6S TL	193.6	5.48	2965	1345
2700R49 2X RL4JII E4 6S TLI E D4505	193.6	5.48	2965	1345
2700R49 2X RM-4A+ 2SL TL	186.2	5.27	3119	1415
2700R49 2X RM-4A+ 2SL TL	186.2	5.27	3119	1415
2700R49 2X RM-4A+ 2SL TL	186.2	5.27	3119	1415
2700R49 2X RM-4A+ 3SL TL	186.2	5.27	3119	1415
2700R49 2X RM-4A+ 3SL TL	186.2	5.27	3119	1415
2700R49 2X RM-4A+ 4SL TL	186.2	5.27	3123	1416
2700R49 2X RM-4A+ 6SL TL	186.2	5.27	3121	1416
2700R49 2X RM-4A+ 6SL TL	186.2	5.27	3119	1415
2700R49 2X RT-4A+ 2SL E-4 TL	186.2	5.27	3119	1415
2700R49 2X RT-4A+ 3SL E-4 TL	186.2	5.27	3119	1415
2700R49 2X RT-4A+ 4S TL	186.2	5.27	3003	1362
2700R49 2X RT-4A+ 4SL E-4 TL	186.2	5.27	3119	1415
2700R49 2X RT-4A+ 6SL E-4 TL	186.2	5.27	3119	1415
2700R49 2X RT4A+ E4 2S TL	186.2	5.27	2999	1360
2700R49 2X RT4A+ E4 6S TL	186.2	5.27	3022	1371
2725-21 16 SAW 7A 2S NYTT	54.9	1.56	364	165
295-25 16 HRLDL3A L3 4S TL	95.3	2.70	1153	523
295-25 22 HRL3A 6S NYTL	95.3	2.70	1293	587
295-25 22 HRL3A E3 4S NYTL	95.3	2.70	1601	726
295-25 22 HRLDL3A 100 4S NYTL	95.3	2.70	1295	587
295-25 22 HRLDL3A 4S NYTL	95.3	2.70	1265	574
295-25 22 HRLDL3A L3 4S NYTL	95.3	2.70	1601	726
295-25 22 HRLDL5C 4S NYTL	99.0	2.80	1566	710
295-25 22 SHRL 4S NYTL	94.2	2.67	1124	510
295-25 28 GRL DL3A L3 4S TL	95.3	2.70	986	447
295-25 28 HRL3A E3 4S NYTL	95.3	2.70	1260	572
295-25 28 HRLDL3A 100 4S NYTL	95.3	2.70	1147	520
295-25 28 HRLDL3A 4S NYTL	95.3	2.70	1101	499
295-25 28 SHRL 4S NYTL	94.2	2.67	1159	526
295-25 28 SHRLXTDL4S NYTL	100.9	2.86	1509	685
295-25 28 SMODL5A 6S NYTL	98.7	2.79	2121	962
295-25 28 SXT DL 4S NYTL	95.3	2.70	1832	831
295-25 34 HRL3A E3 4S NYTL	95.3	2.70	1601	726
295-25 34 HRL3A E3 4S NYTL	95.3	2.70	1601	726
295-25 34 SMODL5E L5S 6S NYTL	95.3	2.70	2002	908
295-29 22 HRL DL3A L3 4S TL	105.7	2.99	1868	847
295-29 22 HRL3A E3 4S TL	105.7	2.99	1868	847
295-29 22 SXT DL 4S NYTL	108.4	3.07	1868	847
295-29 28 HRL3A 2S TL	105.7	2.99	1414	641

Size/Type	Tire Cubeage		Tire Weight	
	Ft ³	M ³	Lbs	Kg
295-29 28 HRL3A 4S NYTL	105.7	2.99	1201	545
295-29 28 HRL3A E3 4S TL	105.7	2.99	1201	545
295-29 28 SHRLXTDL4S NYTL	104.2	2.95	1687	765
295-29 28 SMO DL5C L5S 6J TL	105.7	2.99	1414	641
295-29 28 SMODL5C 6S NYTL	105.7	2.99	2500	1134
295-29 28 SXT DL 4S NYTL	105.7	2.99	1969	893
295-29 34 HRL3A 2S TL	105.7	2.99	1414	641
295-29 34 HRL3A 4S TL	105.7	2.99	1414	641
295-29 34 HRLDL3A L3 4S TL	105.7	2.99	1250	567
295-29 34 HRLDL5A L5 6S NYTL	105.7	2.99	1802	817
295-29 34 SMO5C 2S TL	105.7	2.99	1414	641
295-29 34 SMO5C 6J TL	105.7	2.99	1414	641
295-29 34 SMO5C 6S NYTL	105.7	2.99	2540	1152
295-29 34 SMO5C 6S TL	105.7	2.99	1414	641
295-29 34 SMODL5C L5S 2S TL	105.7	2.99	1250	567
295-29 40 SMO DL5C L5S 6J TL	105.7	2.99	1414	641
295-29 40 SMODL5C L5S 4S TL	105.7	2.99	1414	641
295-29 40 SMODL5C L5S 6S TL	105.7	2.99	1414	641
295-35 28 S HRL 8 4S NYTL	119.3	3.38	1419	644
295R25 1X GP2B 6S TL	94.3	2.67	1205	547
295R25 1X GP4B AT 6S TL	93.5	2.65	1363	618
295R25 1X RL-4K 24/24 L4 6S TL	104.8	2.97	1639	744
295R25 1X RL-5K 24/24 L5 6S TL	104.8	2.97	1975	896
295R25 1X RL2+ L2 6S TL	97.9	2.77	1439	653
295R25 1X RL5K L5 6S TL	104.8	2.97	2091	948
295R25 1X RL5K L5 6S TL	104.8	2.97	2091	948
295R25 200B 2X RL2+ E2 4S TL	95.3	2.70	1403	636
295R25 200B 2X TL-3A+ 4S TL	95.3	2.70	1449	657
295R25 200B 2X TL-3A+ 6S TL	95.3	2.70	1449	657
295R25 208/A2 1X STNGRD RT3B L3/G3 6S TL	95.3	2.70	1449	657
295R25 208/A2 1X TL-3A+ 6S TL	95.3	2.70	1449	657
295R25 2X GP2B 4S TL	94.3	2.67	1240	563
295R25 2X GP4B AT 4S TL	93.5	2.65	1356	615
295R25 2X GP4D HI-STAB 6S L4/E4 TL	95.3	2.70	1522	690
295R25 2X GT-4A 4S TL	95.3	2.70	1363	618
295R25 2X RL-2+ E-2 4S TL	95.3	2.70	1441	654
295R25 2X RL-4K 24/24 L4 6S TL	95.3	2.70	1742	790
295R25 2X RL-4K HI-STABILITY 24/24 L4 6S	95.3	2.70	1742	790
295R25 2X RL-4S 6S A2 TL	95.3	2.70	1742	790
295R25 2X RL-4S HI-STABILITY L4S 6S	95.3	2.70	1742	790
295R25 2X RL-5K 00/24 TL	95.3	2.70	2049	929
295R25 2X RL-5K 24/24 L5 6S TL	95.3	2.70	2049	929
295R25 2X RL-5K HI-STABILITY 24/24 L5 6S	95.3	2.70	1742	790
295R25 2X RL-5S HI-STABILITY L-5S 6S	95.3	2.70	1742	790
295R25 2X RL-5S L-5S 6S TL	95.3	2.70	720	327

APPROXIMATE SHIPPING DATA

Size/Type	Tire Cubeage		Tire Weight	
	Ft ³	M ³	Lbs	Kg
295R25 2X RL2+ E2 4S TL	97.9	2.77	1460	662
295R25 2X RL2+ E2 6S TL	95.3	2.70	1250	567
295R25 2X RL5K L5 6S TL	95.3	2.70	2138	970
295R25 2X RT-3B HI-STAB 6S TL	95.3	2.70	1132	513
295R25 2X TL-3A+ 4S TL	95.3	2.70	1481	672
295R25 2X TL-3A+ 6S RPTL	95.3	2.70	1482	672
295R25 2X TL-3A+ HI-STAB 6S L-3+T/E-3+T	95.3	2.70	706	320
295R25 2XRL-5K HI-STABILITY 00/24 L-5 6S	95.3	2.70	1742	790
295R25 C1 TL-3A+ 4S TL	95.3	2.70	1481	672
295R25 TL-3A+ 2X HI-STABILITY 4S TL	95.3	2.70	1449	657
295R29 1X RL-4K 24/24 L4 6S TL	105.7	2.99	1785	810
295R29 1X RL-5K 24/24 L5 6S TL	105.7	2.99	2076	942
295R29 218/A2 2X RL5S HI STAB L5 6S TL	105.7	2.99	2194	995
295R29 223/A2 3X RL5S HI STAB L5 6S TL	105.7	2.99	2504	1136
295R29 2X RL-5K 24/24 L5 4S TL	105.7	2.99	2096	951
295R29 2X RL-5K 24/24 L5 6S TL	105.7	2.99	2111	958
295R29 2X RL2+ 6S TL	95.3	2.70	2200	998
295R29 2X RL2+ E2 4S TL	108.7	3.08	1499	680
295R29 2X RL2+ E2 4S TL	108.7	3.08	1499	680
295R29 2X RL2+ E2 6S TL	108.7	3.08	1506	683
295R29 2X RL2F E2 4S TL	104.0	2.94	1344	610
295R29 2X RL3 E3 4S TL	104.7	2.96	1641	744
295R29 2X RL3 E3 6S TL	104.7	2.96	1650	748
295R29 RL-2+ C1*1*+2* 2S L-2/E-2 TL	95.3	2.70	2200	998
295R29 RL-2+ C1*1*+2* 4S L-2/E-2 TL	95.3	2.70	2200	998
295R29 RL-2+ C1*1*+2* 6S L-2/E-2 TL	95.3	2.70	2200	998
30/65R25 2X RL2+ 4S TL	71.8	2.03	900	408
30/65R25 2X RL2+ 4S TL	71.8	2.03	900	408
3000-51 46 HRL4B 4S NYTL	245.9	6.96	3641	1652
3000-51 46 MRL4E E4 2S NYTL	240.3	6.80	3370	1529
3000-51 46 MRL4E E4 4S NYTL	240.3	6.80	3370	1529
3000-51 52 HRL4B 2S E4 NYTL	240.3	6.80	3811	1729
3000-51 52 HRL4B E4 4S NYTL	240.3	6.80	3822	1734
3000-51 52 MRL4E E4 2S NYTL	240.3	6.80	3370	1529
3000-51 52 MRL4E E4 4S NYTL	240.3	6.80	3370	1529
3000R51 2X RL4H 3H TL	240.3	6.80	4089	1855
3000R51 2X RL4H E4 3H TL	240.3	6.80	4011	1819
3000R51 2X RL4H E4 3S TL	260.6	7.38	4024	1825
3000R51 2X RL4H E4 4S TL	260.6	7.38	4046	1835
3000R51 2X RL4JII E4 3S TL	260.7	7.38	3947	1790
3000R51 2X RL4JII E4 4S TL	260.7	7.38	3949	1791
32-15-15 20 TR MS NYTT	8.9	0.25	129	59
32-15-15 24 XTRWL MSAR NYTL	8.8	0.25	168	76
32-15-15 24 XTRWL MSAR NYTL N0000	5.7	0.16	168	76
3300-51 58 HRL4B 4S NYTL	289.7	8.20	4397	1995

Size/Type	Tire Cubeage		Tire Weight	
	Ft ³	M ³	Lbs	Kg
3300-51 58 HRL4B E4 2S NYTL	289.7	8.20	4398	1995
3300R51 2X GP4B 2S TL	289.7	8.20	5041	2287
3300R51 2X GP4B E4 3H TL	289.7	8.20	5041	2287
3300R51 2X RL-4C E4 2H TL	289.7	8.20	5041	2287
3300R51 2X RL-4M+ 2SL E-4 TL	289.7	8.20	3181	1443
3300R51 2X RL-4M+ 3SL E-4 TL	289.7	8.20	3181	1443
3300R51 2X RL-4M+ 4SL E-4 TL	289.7	8.20	3181	1443
3300R51 2X RL-4M+ 6SL E-4 TL	289.7	8.20	3181	1443
3300R51 2X RL3J E3 2S TL	289.7	8.20	4125	1871
3300R51 2X RL3J E3 3S TL	289.7	8.20	4360	1977
3300R51 2X RL3J E3 4S TL	289.7	8.20	4130	1873
3300R51 2X RL4C 3H TL	289.7	8.20	5041	2287
3300R51 2X RL4C 6H TL	289.7	8.20	5041	2287
3300R51 2X RL4C E4 2H TL	289.7	8.20	5041	2287
3300R51 2X RL4C E4 6H TL	289.7	8.20	5041	2287
3300R51 2X RL4H E4 2H TL	308.9	8.75	5135	2329
3300R51 2X RL4H E4 2H TL D4926	308.9	8.75	5135	2329
3300R51 2X RL4H E4 3H TL	308.9	8.75	5138	2330
3300R51 2X RL4H E4 3H TL 039441	308.9	8.75	5138	2330
3300R51 2X RL4H E4 4H TL	308.9	8.75	5141	2332
3300R51 2X RL4H E4 6H TL	308.9	8.75	5171	2345
3300R51 2X RL4HII E4 3H TL	312.3	8.84	5138	2330
3300R51 2X RL4HII E4 4H TL	312.3	8.84	5141	2332
3300R51 2X RL4JII E4 2H TL	312.3	8.84	5135	2329
3300R51 2X RL4JII E4 3H TL	260.7	7.38	5138	2330
3300R51 2X RL4JII E4 4H TL	260.7	7.38	5141	2332
3300R51 2X RL4JII E4 6H TL	260.7	7.38	5171	2345
3300R51 3X RL-4A+ 2SL E-4 TL	289.7	8.20	5138	2330
3300R51 3X RL-4A+ 3SL E-4 TL	289.7	8.20	5138	2330
3300R51 3X RL-4A+ 4SL E-4 TL	289.7	8.20	5138	2330
3300R51 3X RM-4A+ E4 2SL TL	289.7	8.20	5202	2360
3300R51 3X RM-4A+ E4 3SL TL	289.7	8.20	5202	2360
3300R51 3X RM-4A+ E4 4SL TL	289.7	8.20	5209	2363
3300R51 3X RM-4A+ E4 6SL TL	289.7	8.20	5138	2330
3325-29 26 S HRL 8 4S NYTL	130.4	3.69	1443	655
3325-29 32 S HRL 8 4S NYTL	130.4	3.69	1576	715
3325-35 32 HRL3F 6S TL	153.5	4.35	1853	840
3325-35 32 HRL3F E3 2S TL	153.5	4.35	1853	840
3325-35 32 S HRL 8 4S NYTL	149.3	4.23	1771	803
3325-35 38 HRL 3B E-3 4S TL	153.5	4.35	1914	868
3325-35 38 HRL 3F 400 4S TL	153.5	4.35	1914	868
3325-35 38 HRL3F 4S NYTL	149.3	4.23	1976	896
3325-35 38 HRL3F E3 2S TL	153.5	4.35	1853	840
3325-35 38 HRL3F E3 4S TL	153.5	4.35	1853	840
3325-35 38 S HRL 8 4S NYTL	149.3	4.23	1935	878

APPROXIMATE SHIPPING DATA

Size/Type	Tire Cubeage		Tire Weight	
	Ft ³	M ³	Lbs	Kg
3325-35 50 HRLDL3F 4S NYTL	155.3	4.40	2142	972
3325-35 50 S HRL 8 DL L3 4S TL	153.5	4.35	2142	972
3325-35 50 SHRL 8 DL L3 4S TL	153.5	4.35	1999	907
3325R29 2X RT-3A E3 4S TL	133.7	3.79	1807	820
3325R35 2X RL3J E3 4S TL	157.5	4.46	2235	1014
335-33 38 HRL3F 4S NYTL	154.7	4.38	1800	816
35-15-15 28 TR MS NYTL	10.6	0.30	177	80
35-15-15 28 XTRWL MSAR NYTL	10.6	0.30	211	95
35-15-15 28 XTRWL MSAR NYTL N0000	5.7	0.16	211	95
35-15-15 32 XTRWL MSAR NYTL	10.6	0.30	230	104
35-15-15 32 XTRWL MSAR NYTL N0000	5.7	0.16	230	104
35/65-33 24 NRL D/L 4A4J SBTL	133.9	3.79	1956	887
35/65-33 24 NRL D/L 5A 4J SBTL	124.8	3.53	2409	1093
35/65-33 24 NRL D/L 5A 6J SBTL	124.8	3.53	2223	1008
35/65-33 24 NSMDL 5B 6J SBTL	133.9	3.79	2497	1132
35/65-33 30 NRL D/L 4A4J SBTL	133.9	3.79	2111	958
35/65-33 30 NRL D/L 5A 4J SB	124.8	3.53	2487	1128
35/65-33 30 NRL D/L 5A 6J SBTL	124.8	3.53	2491	1130
35/65-33 30 NRL D/L 5A4J SBTL	132.1	3.74	2487	1128
35/65-33 30 NRL D/L-4A L4 6J TL	124.8	3.53	2594	1176
35/65-33 36 NRL4A 2J TL	124.8	3.53	2391	1085
35/65-33 36 NRL5A 2J TL	124.8	3.53	2391	1085
35/65-33 36 NRLDL4A L4 2J TL	124.8	3.53	2391	1085
35/65-33 36 NRLDL5A L5 2J TL	124.8	3.53	2391	1085
35/65-33 36 NRLDL5A L5 4J SBTL	124.8	3.53	2391	1085
35/65-33 36 NRLDL5A L5 6J SBTL	124.8	3.53	2391	1085
35/65-33 42 NRL D/L 5A 100 4J SBTL	124.8	3.53	2752	1248
35/65-33 42 NRL D/L 5A 100 6J SBTL	124.8	3.53	2784	1263
35/65-33 42 NRL D/L 5A6J SBTL	124.8	3.53	2764	1254
35/65-33 42 NRL D/L-5A 4J TL	124.8	3.53	2723	1235
35/65-33 42 NSMDL5B L-5S 6J TL	124.8	3.53	2867	1300
35/65R33 1X RL4K 6S TL	138.2	3.91	2026	919
35/65R33 1X RL5K L5 6S TLDD	138.2	3.91	2392	1085
35X15R15NHS 3X RL5K 12/12 L5 6S TL	10.6	0.30	233	106
35X15R15NHS 3X RL5K 12/12 L5 6S TL N0000	10.6	0.30	233	106
35X15R15NHS 3X RL5K 24/24 L5 6S TL	10.6	0.30	225	102
35X15R15NHS 3X RL5K 24/24 L5 6S TL	10.6	0.30	128	58
36-11-15 16 TR MS NYTT	8.3	0.23	125	57
36-11-15 24 XTRWLMAUMS NYTT	3.0	0.09	169	76
36-11-15 24 XTRWLMAUMS NYTT N0000	19.9	0.56	169	76
3600-51 42 SRB 7A 4S NYTL	338.1	9.57	3163	1435
3600-51 58 HRL-4B 4S NYTL	357.1	10.11	6205	2814
3600-51 58 HRL4B 100 2S NYTL	357.1	10.11	6202	2813
3600R51 2X RL3 E3 2S P0E7040 TL	357.0	10.11	5683	2578
3600R51 2X RL3 E3 2S TL	357.0	10.11	5683	2578

Size/Type	Tire Cubeage		Tire Weight	
	Ft ³	M ³	Lbs	Kg
3600R51 2X RL4H E4 2S TL	389.3	11.02	5918	2685
3600R51 2X RL4H E4 2S TL D2351	389.3	11.02	5918	2685
3600R51 2X RL4H E4 3H TL	357.0	10.11	6155	2792
3600R51 2X RL4H E4 3S TL	387.4	10.97	5923	2687
3600R51 2X RL4H E4 4H TL	357.0	10.11	5876	2665
3600R51 2X RL4H E4 4H TL	387.4	10.97	6159	2794
3600R51 2X RL4H E4 4H TL D5064	387.4	10.97	6159	2794
3600R51 2X RL4H E4 4H TL D5369	387.4	10.97	6159	2794
3600R51 2X RL4H E4 4S TL	389.3	11.02	5928	2689
3600R51 2X RL4H E4 4S TL D4557	389.3	11.02	5928	2689
3600R51 2X RL4JII E4 3S TL	389.3	11.02	6016	2729
3600R51 2X RL4JII E4 4S TL	389.3	11.02	5549	2517
36X11R15NHS 3X RL5K 12/12 L5 6S TL	8.3	0.23	194	88
36X11R15NHS 3X RL5K 24/24 L5 6S TL	8.3	0.23	116	52
36X11R15NHS 3X RL5K 24/24 L5 6S TL	8.3	0.23	189	86
3700R57 2X GP-4C E4 2H TL	415.8	11.77	7466	3387
3700R57 2X GP-4C E4 4H TL	415.8	11.77	7466	3387
3700R57 2X GP4C 2S TL	415.8	11.77	7333	3326
3700R57 2X RL-4H E-4 2S TL	415.8	11.77	6735	3055
3700R57 2X RL-4H IIR E4 2H TL	415.8	11.77	7056	3200
3700R57 2X RL-4H IIR E4 2S TL	415.8	11.77	7056	3200
3700R57 2X RL-4H IIR E4 3H TL	415.8	11.77	7056	3200
3700R57 2X RL-4H IIR E4 4H TL	415.8	11.77	7056	3200
3700R57 2X RL-4H IIR E4 4S TL	415.8	11.77	7056	3200
3700R57 2X RL-4H IIR E4 6H TL	415.8	11.77	7056	3200
3700R57 2X RL-4J IIR E4 2H TL	415.8	11.77	7056	3200
3700R57 2X RL-4J IIR E4 3H TL	415.8	11.77	7056	3200
3700R57 2X RL-4J IIR E4 4H TL	415.8	11.77	7056	3200
3700R57 2X RL-4J IIR E4 6H TL	415.8	11.77	7056	3200
3700R57 2X RL-4M+ E4 2SL TL	415.8	11.77	7444	3376
3700R57 2X RL-4M+ E4 4SL P9E5081 TL	415.8	11.77	7454	3381
3700R57 2X RL-4M+ E4 4SL TL	415.8	11.77	7454	3381
3700R57 2X RL-4M+ E4 6SL TL	415.8	11.77	7702	3494
3700R57 2X RL4C E4 2H TL	415.8	11.77	6269	2844
3700R57 2X RL4C E4 3H TL	415.8	11.77	6269	2844
3700R57 2X RL4C E4 6H TL	415.8	11.77	6269	2844
3700R57 2X RL4H E4 2H TL	448.4	12.70	7362	3339
3700R57 2X RL4H E4 2HR TL	448.4	12.70	7586	3441
3700R57 2X RL4H E4 3H TL	448.4	12.70	7333	3326
3700R57 2X RL4H E4 4H P0E7062 TL	415.8	11.77	7466	3387
3700R57 2X RL4H E4 4H P0E7301 TL	415.8	11.77	7678	3482
3700R57 2X RL4H E4 4H P4E7001 TL	415.8	11.77	7678	3482
3700R57 2X RL4H E4 4H TL	415.8	11.77	7466	3387
3700R57 2X RL4H E4 4H TL	448.4	12.70	7678	3482
3700R57 2X RL4H E4 4S TL	415.8	11.77	6855	3110

APPROXIMATE SHIPPING DATA

Size/Type	Tire Cubeage		Tire Weight	
	Ft ³	M ³	Lbs	Kg
3700R57 2X RL4H E4 6H TL	415.8	11.77	7466	3387
3700R57 2X RL4H E4 6H TL	415.8	11.77	7375	3345
3700R57 2X RL4H E4 6H TL D5052	448.4	12.70	7375	3345
3700R57 2X RL4HIII E4 2H TL	449.3	12.72	7495	3400
3700R57 2X RL4HIII E4 2HR TL	449.3	12.72	7407	3360
3700R57 2X RL4HIII E4 4H TL	449.3	12.72	7695	3490
3700R57 2X RL4HIII E4 4HR TL	449.3	12.72	7435	3372
3700R57 2X RL4HIII E4 6H TL	415.8	11.77	7691	3489
3700R57 2X RL4JII E4 2HR TL	449.3	12.72	7526	3414
3700R57 2X RL4JII E4 3H TL	415.8	11.77	7466	3387
3700R57 2X RL4JII E4 4HR TL	449.3	12.72	7280	3302
3700R57 2X RL4JII E4 6H TL	449.3	12.72	7521	3412
3700R57 2X RL4M+ E4 3SL TL	415.8	11.77	7449	3379
3700R57 2X RM-4A+ 2SL E-4 TL	415.8	11.77	7466	3387
3700R57 2X RM-4A+ 2SL E-4 TL	415.8	11.77	7427	3369
3700R57 2X RM-4A+ 3SL E-4 TL	415.8	11.77	7466	3387
3700R57 2X RM-4A+ 3SL E-4 TL	415.8	11.77	7427	3369
3700R57 2X RM-4A+ 4SL E-4 TL	415.8	11.77	7466	3387
3700R57 2X RM-4A+ 4SL E-4 TL	415.8	11.77	7437	3373
3700R57 2X RM-4A+ 6SL E-4 TL	415.8	11.77	7466	3387
3725-35 30 HRL3B 4S NYTL	195.4	5.53	2204	1000
3725-35 30 HRL3F 4S NYTL	201.4	5.70	2293	1040
3725-35 30 HRL3F 6S NYTL	195.4	5.53	2293	1040
3725-35 30 S HRL 8 4S NYTL	201.4	5.70	2192	994
3725-35 36 HRL 3F 400 4S NYTL	195.4	5.53	2414	1095
3725-35 36 HRL3B 4S NYTL	195.4	5.53	2208	1002
3725-35 36 HRL3B E3 4S NYTL	195.4	5.53	2208	1002
3725-35 36 HRL3F 4S NYTL	201.4	5.70	2436	1105
3725-35 36 HRL3F E3 2S NYTL	195.4	5.53	2400	1089
3725-35 36 HRL3F E3 4S NYTL	195.4	5.53	2400	1089
3725-35 36 HRL3F E3 6S NYTL	195.4	5.53	2400	1089
3725-35 36 HRL3F E3 6S TL	195.4	5.53	2436	1105
3725-35 42 HRL3F 4S NYTL	201.4	5.70	2584	1172
3725R35 2X RL3J E3 4S TL	205.0	5.80	2866	1300
3725R35 2X RL3J E3 6S TL	205.0	5.80	2881	1307
3725R35 2X RL3J E3 6S TL SO D1807	205.0	5.80	2881	1307
375-33 42 HRL3F 4S NYTL	203.0	5.75	2504	1136
375-33 42 HRL3F E3 4S NNTL	196.7	5.57	2504	1136
375-39 44 HRL3B E3 4S TL	223.4	6.33	2823	1281
375-39 44 HRL3F 4S NYTL	203.0	5.75	2799	1270
375-39 44 HRLDL5A 4S NYTL	225.8	6.39	4242	1924
375-39 52 HRL 3F 400 4S NYTL	223.4	6.33	3012	1366
375-39 52 HRL-3F E-3 2S TL	223.4	6.33	2799	1270
375-39 52 HRL-3F E-3 4S TL	223.4	6.33	2799	1270
375-39 52 HRL-3F E-3 6S TL	223.4	6.33	2799	1270

Size/Type	Tire Cubeage		Tire Weight	
	Ft ³	M ³	Lbs	Kg
375-39 52 HRL-3F E-3 6S TL	223.4	6.33	2799	1270
375-39 52 HRL3F 4S NYTL	203.0	5.75	2827	1282
375-39 52 HRL3F E3 6S TL	223.4	6.33	2799	1270
375R39 2X RL3J E3 2S TL	223.4	6.33	3223	1462
375R39 2X RL3J E3 4S TL	224.5	6.36	3226	1463
375R39 2X RL3J E3 4S TL	223.4	6.33	3226	1463
375R39 2X RL3J E3 6S TL	223.4	6.33	3241	1470
38-16-15 32 RKMS AR TL	13.4	0.38	237	107
38-16-15 32 RKMS AR TL N0000	13.4	0.38	237	107
38-16-15NHS 40 RKMS AR NYTL	13.4	0.38	272	123
38-16-15NHS 40 RKMS AR NYTL N0000	13.4	0.38	272	123
385/95R24 00 GP2B TT	24.5	0.69	348	158
385/95R25 00 GP2B 170E TL	25.4	0.72	380	172
385/95R25 00 GP2B TL	25.2	0.71	364	165
385/95R25 170E 3X AS-3A E3 RPTL	25.4	0.72	371	168
395/85R20 1X MV/T STTL	19.4	0.55	206	93
395/85R20 2X MV/T STTL	19.4	0.55	225	102
4000R57 2X RL3A E3 2S TL	491.0	13.90	7333	3326
4000R57 2X RL3A E3 2SW TL	491.0	13.90	7853	3562
4000R57 2X RL4B 4SW TL	491.0	13.90	8102	3675
4000R57 2X RL4B ARC E4 4SL TL	491.0	13.90	7943	3603
4000R57 2X RL4B ARCTIC E4 3H TL	491.0	13.90	8479	3846
4000R57 2X RL4B ARCTIC E4 3SL TL	491.0	13.90	8022	3639
4000R57 2X RL4B ARCTIC E4 4H TL	491.0	13.90	8389	3805
4000R57 2X RL4B ARCTIC E4 4SL TL	491.0	13.90	7943	3603
4000R57 2X RL4B E4 2H TL	508.4	14.40	8489	3851
4000R57 2X RL4B E4 2HR TL	508.4	14.40	8397	3809
4000R57 2X RL4B E4 2HW TL	491.0	13.90	8636	3917
4000R57 2X RL4B E4 2SL TL	491.0	13.90	7965	3613
4000R57 2X RL4B E4 2SW TL	491.0	13.90	8369	3796
4000R57 2X RL4B E4 2SWL TL	491.0	13.90	8324	3776
4000R57 2X RL4B E4 3H TL	508.4	14.40	8127	3687
4000R57 2X RL4B E4 3H TL D6186	508.4	14.40	8127	3687
4000R57 2X RL4B E4 3HW TL	508.4	14.40	8642	3920
4000R57 2X RL4B E4 3SL TL	491.0	13.90	7969	3615
4000R57 2X RL4B E4 3SW TL	491.0	13.90	8127	3687
4000R57 2X RL4B E4 4HW TL	508.4	14.40	8647	3922
4000R57 2X RL4B E4 4SL TL	491.0	13.90	7974	3617
4000R57 2X RL4B E4 4SL TL	491.0	13.90	8086	3668
4000R57 2X RL4B E4 6SL TL	491.0	13.90	8116	3681
4000R57 2X RL4H E4 2H TL	508.4	14.40	8457	3836
4000R57 2X RL4H E4 3H TL	508.4	14.40	8463	3839
4000R57 2X RL4H E4 3H TL 038094	508.4	14.40	8463	3839
4000R57 2X RL4H E4 4H TL	508.4	14.40	8467	3841
4000R57 FB GR-4H 2X HR E4 TL	491.0	13.90	8302	3766

APPROXIMATE SHIPPING DATA

Size/Type	Tire Cubeage		Tire Weight	
	Ft ³	M ³	Lbs	Kg
405/75R39 1X RL4K L4 6S TL	240.4	6.81	3595	1631
405/75R39 2X GP2B 4S TL	240.4	6.81	3302	1498
405/75R39 2X GP2B 6S TL	240.4	6.81	3318	1505
405/75R39 2X RT-3A+ E3 4S TL	233.2	6.60	3731	1692
405/75R39 2X RT-3A+ E3 6S TL	233.2	6.60	3733	1693
4125/70-39 42 NRL D/L 5A6J SBTL	235.9	6.68	4173	1893
42-13-20NHS 24 RKMS AR NYTT	13.3	0.38	452	205
42-13-20NHS 24 RKMS AR NYTT N0000	19.0	0.54	452	205
42-13-20NHS 32 XTRWL MSAR NYTT	13.3	0.38	249	113
42-13-20NHS 48 XTRWL MSAR NYTL	13.3	0.38	301	136
44-18-20 32 XTRWL MSAR NYTL	2.1	0.06	368	167
44-18-20 32 XTRWL MSAR NYTL N0000	19.9	0.56	368	167
44-18-20NHS 36 XTRWL MSAR NYTL	20.2	0.57	372	169
44-18-20NHS 36 XTRWL MSAR NYTL N0000	20.2	0.57	372	169
44-18-20NHS 48 XTRWL MSAR NYTL	20.2	0.57	442	200
44-18-20NHS 48 XTRWL MSAR NYTL N0000	20.2	0.57	442	200
44/95R57 2X RL4B E4 2H TL	503.4	14.25	8440	3828
44/95R57 2X RL4B E4 2HW TL	503.4	14.25	8587	3895
445/90R21 173G M AT-2A TL	28.0	0.79	335	152
445/95R25 00 GP2B 177E TL	34.2	0.97	505	229
445/95R25 J UNISTEEL MC-1A 177E TL	34.4	0.98	425	193
445/95R25 J UNISTEEL MC-1A 177G TL	34.4	0.98	425	193
445/95R25 MC-1A 3X TL RP	34.4	0.98	425	193
45/65-45 38 NDL5L15C L5 6J TL	279.0	7.90	4784	2170
45/65-45 38 NRL D/L 5A6J SBTL	301.5	8.54	4993	2265
45/65-45 38 NRLDL 5A2S FBTL	301.5	8.54	4776	2166
45/65-45 38 NRLDL5/15C L5 6J SBTL	279.0	7.90	6083	2759
45/65-45 38 NSMDL5B L5S 4J TL	279.0	7.90	6083	2759
45/65-45 38 NSMDL5B L5S 6J SBTL	279.0	7.90	6083	2759
45/65-45 46 NDL5L15C L5 4J TL	279.0	7.90	5583	2532
45/65-45 46 NDL5L15C6J SBTL	301.5	8.54	5609	2544
45/65-45 46 NRLDL 5A2S FBTL	301.5	8.54	4781	2169
45/65-45 46 NRLDL5/15C L5 4J TL	279.0	7.90	5419	2458
45/65-45 46 NRLDL5A L5 4H TL	279.0	7.90	5175	2348
45/65-45 46 NRLDL5A L5 6H TL	279.0	7.90	5245	2379
45/65-45 46 NSMDL5B L5S 4J TL	279.0	7.90	4784	2170
45/65-45 50 NRLDL5A L5 6J SBTL	279.0	7.90	6083	2759
45/65-45 58 NDL-15C 5J TL	279.0	7.90	5603	2541
45/65-45 58 NDL5L15C6J SBTL	279.0	7.90	5925	2688
45/65-45 58 NRLDL-4D 4J L-4 TL	279.0	7.90	5504	2496
45/65-45 58 NRLDL 5A4J SBTL	301.5	8.54	5290	2399
45/65-45 58 NRLDL5/15C L5 4J SBTL	279.0	7.90	6083	2759
45/65-45 58 NRLDL5/15C L5 6H BPTL	279.0	7.90	5603	2541
45/65-45 58 NRLDL5/15C L5 6J SBTL	279.0	7.90	6083	2759
45/65-45 58 NRLDL5A 6J SB P9E0020 TL	279.0	7.90	5344	2424

Size/Type	Tire Cubeage		Tire Weight	
	Ft ³	M ³	Lbs	Kg
45/65-45 58 NRLDL5A 6J SBTL	301.5	8.54	5344	2424
45/65-45 58 NRLDL5A 6J SBTL 041384	301.5	8.54	5344	2424
45/65-45 58 NRLDL5A L5 2J TL	279.0	7.90	4784	2170
45/65-45 58 NRLDL5A L5 4H TL	279.0	7.90	5504	2496
45/65-45 58 NRLDL5A L5 6H TL	279.0	7.90	5563	2523
45/65-45 58 NSMDL5B L5S 6H BPTL	279.0	7.90	5603	2541
45/65-45 58 NSMDL5B L5S 6J SBTL	279.0	7.90	6083	2759
45/65R39 1X RL-5K 20/20 L5 4S TL	247.6	7.01	4761	2159
45/65R39 1X RL-5K 20/20 L5 6S TL	247.6	7.01	4801	2178
45/65R45 1X RL-4K 20/20 L4 4S TL	279.0	7.90	4655	2111
45/65R45 1X RL-4K 20/20 L4 6S TL	279.0	7.90	4684	2125
45/65R45 1X RL-5K 05/05 L5 6S TL	279.0	7.90	5850	2654
45/65R45 1X RL-5K 20/20 L5 4S TL	279.0	7.90	5495	2492
45/65R45 1X RL-5K 20/20 L5 6S TL	279.0	7.90	5539	2513
45R57 2X TWO PIECE 2H E4 ASSY	514.1	14.56	9810	4450
46/90R57 251/B 2X RL4B E4 4SL TL	520.3	14.73	8157	3700
46/90R57 251/B 2X RL4B E4 4SL TL	520.3	14.73	8157	3700
46/90R57 251/B 2X RL4B E4 6SL TL	520.3	14.73	8341	3783
46/90R57 2X RL-4B ARCTIC 2SL E4 TL	520.3	14.73	8436	3826
46/90R57 2X RL-4B ARCTIC 3SL E4 TL	520.3	14.73	8436	3826
46/90R57 2X RL4B E4 2SL P9E5021 TL	520.3	14.73	8148	3696
46/90R57 2X RL4B E4 2SL P9E5100 TL	520.3	14.73	8148	3696
46/90R57 2X RL4B E4 2SL TL	520.3	14.73	8148	3696
46/90R57 2X RL4B E4 3SL	520.3	14.73	8152	3698
46/90R57 2X RL4B E4 3SL	520.3	14.73	8152	3698
46/90R57 2X RL4B E4 4SLTL	520.3	14.73	8157	3700
46/90R57 RM-4A+ 252B 2X E-4 2SL TL	520.3	14.73	8205	3722
46/90R57 RM-4A+ 252B 2X E-4 3SL TL	520.3	14.73	8205	3722
46/90R57 RM-4A+ 252B 2X E-4 4SL TL	520.3	14.73	8215	3726
46X15R20NHS 3X RL5K 24/24 L5 6S TL	18.4	0.52	435	197
46X18R20NHS 3X RL5K 24/24 4S L5 PE7E5180	20.0	0.57	2049	929
480/95R25 3X EV-4S INDUSTRIAL 00/00 TL	40.6	1.15	707	320
480/95R25 EV-4A 00/12 199 TL	40.6	1.15	707	320
480/95R25 EV-4A 24/24 199 TL	40.6	1.15	708	321
50-20-20NHS 28 RKMS AR NYTT	27.5	0.78	453	205
50-20-20NHS 36 RKMS AR NYTL	28.9	0.82	449	204
50-20-20NHS 36 XTR3C AR NYTL	28.9	0.82	454	206
50-20-20NHS 36 XTR3C AR NYTL N0000	28.9	0.82	454	206
50/65-51 50 NRL D/L 5A6J SBTL	389.4	11.03	7845	3559
50/65-51 54 NRL D/L 5A6J SBTL	389.4	11.03	7704	3494
50/65-51 62 NRL D/L 5A4J SBTL	431.9	12.23	7733	3508
50/65-51 62 NRL D/L 5A4S NYTL	389.4	11.03	7624	3458
50/65-51 62 NRL D/L 5A4S NYTL 036098	389.4	11.03	7624	3458
50/80-57 68 HRL4/15C6J SGNYTL	543.1	15.38	9500	4309
50/80-57 68 HRL4/15C6J SGNYTL D4477	543.1	15.38	9500	4309

APPROXIMATE SHIPPING DATA

Size/Type	Tire Cubeage		Tire Weight	
	Ft ³	M ³	Lbs	Kg
52/80-57 68 DRL4/15C L4 6J SG TL	591.5	16.75	10000	4536
52/80-57 68 DRL4/15C4J SGNYYTL	597.4	16.92	10254	4651
52/80-57 68 DRL4/15C4J SGNYYTISO D4977	597.4	16.92	10254	4651
52/80-57 68 DRLDL4/15C L4 2J SG TL	591.5	16.75	10000	4536
52/80-57 68 DRLDL4/15C L4 4J SG TL	591.5	16.75	10000	4536
52/80-57 68 DRLDL4/15C L4 5J SG TL	591.5	16.75	10000	4536
52/80-57 68 HRLDL4G 4J SGNYYTL	597.4	16.92	9886	4484
52/80-57 68 HRLDL4G 4J SGNYYTISO D4976	597.4	16.92	9885	4484
52/80-57 68 HRLDL4G 6J SGNYYTL	597.4	16.92	10044	4556
52/80-57 68 HRLDL4G L4 2S TL	591.5	16.75	10000	4536
52/80-57 68 HRLDL4G L4 4J SG TL	591.5	16.75	10000	4536
52/80-57 68 HRLDL4G L4 4S SG TL	591.5	16.75	10000	4536
52/80-57 68 HRLDL4G L4 6J SG TL	591.5	16.75	10000	4536
52/80-57 68 HRLDL4G L4 6S TL	591.5	16.75	10000	4536
525/80R25 00 GP2B 179E TL	40.8	1.16	492	223
53/80R63 2X RM-4A+ 3SL E-4 RP TL	670.0	18.97	9802	4446
53/80R63 2X RM-4A+ 4SL E-4 RP TL	670.0	18.97	9802	4446
53/80R63 2X RM3A E3 2SL TL	670.0	18.97	9802	4446
53/80R63 2X RM3A E3 2SL TL 95411	670.0	18.97	9802	4446
53/80R63 2X RM3A E3 2SL TL 95412	670.0	18.97	9802	4446
53/80R63 2X RM3A E3 2SL TL 95413	670.0	18.97	9802	4446
53/80R63 2X RM3A E3 3SL TL	670.0	18.97	9802	4446
53/80R63 2X RM3A E3 4SL TL	670.0	18.97	9802	4446
53/80R63 2X RM4A E4 2SL TL	670.0	18.97	8194	3717
550/65R25 1X GP3D 6S TL	35.4	1.00	673	305
555/65R25 00 172E AT2A TL	37.0	1.05	461	209
59/80R63 2X RM-4A+ 2SL E-4 RP TL	845.9	23.95	8194	3717
59/80R63 2X RM-4A+ 3SL E-4 RP TL	845.9	23.95	11420	5180
59/80R63 2X RM-4A+ 4SL E-4 RP TL	845.9	23.95	8194	3717
59/80R63 2X RM3A E3 2SL TL	845.9	23.95	11420	5180
59/80R63 2X RM3A E3 2SL TL 95050U	845.9	23.95	11420	5180
59/80R63 2X RM3A E3 2SL TL 95052U	845.9	23.95	11420	5180
59/80R63 2X RM3A E3 2SL TL 95053U	845.9	23.95	11420	5180
59/80R63 2X RM3A E3 3SL TL	845.9	23.95	8194	3717
59/80R63 2X RM3A E3 3SL TL 95054	845.9	23.95	8194	3717
59/80R63 2X RM3A E3 3SL TL 95055	845.9	23.95	8194	3717
59/80R63 2X RM3A E3 3SL TL 95056	845.9	23.95	8194	3717
59/80R63 2X RM3A E3 4SL TL	845.9	23.95	11420	5180
59/80R63 2X RM3A E3 4SL TL 95057	845.9	23.95	11420	5180
59/80R63 2X RM3A E3 4SL TL 95058	845.9	23.95	11420	5180
59/80R63 2X RM3A E3 4SL TL 95059	845.9	23.95	11420	5180
600/65R25 1X GP3D 6S TL	42.4	1.20	600	272
600/65R25 GP-3D C1*+2* L-3/E-3 6S TL	42.4	1.20	600	272
61-1800-25 44 R TOWSV 4S NYTL	42.6	1.21	672	305
650/65R25 193A2 1X GP3D L3 4S TL	50.3	1.42	628	285

Size/Type	Tire Cubeage		Tire Weight	
	Ft ³	M ³	Lbs	Kg
650/65R25 193A2 1X GP3D L3 6S TL	50.3	1.42	631	286
650/65R25 1X GP3D L3/E3 4S TL	50.3	1.42	622	282
650/65R25 2X GP3D E3 4S TL	50.3	1.42	537	244
650/65R25 2X GP3D E3 6S TL	50.3	1.42	683	310
650/65R25 GP-3D C1*+2* L-3/E-3 6S TL	50.3	1.42	631	286
750/65R25 1X GP3D 6S TL	68.7	1.94	899	408
750/65R25 2X GP3D 4S TL	68.7	1.94	915	415
750/65R25 2X GP3D 6S TL	68.7	1.94	899	408
750/65R25 2X RL2+ 4S TL	68.7	1.94	900	408
750/65R25 2X RL2+ 6S TL	68.7	1.94	894	405
750/65R25 2X TL-3A 6S E-3+T TL	68.7	1.94	894	405
750/65R25 2X TL-3A+ 4S E-3+T TL	68.7	1.94	894	405
750/65R25 2X TL-3A+ 6S L-3+T TL	68.7	1.94	894	405
750/65R25 C1 1+2 STAR TL-3A+ 4S E-3+T	68.7	1.94	894	405
750/65R25 C1 1+2 STAR TL-3A+ 6S E-3+T	68.7	1.94	954	433
750/65R25 GP-3D C1*+2* L-3/E-3 6S TL	68.7	1.94	899	408
775/65R29 195B 2X GP4D 4S TL	83.3	2.36	721	327
775/65R29 195B 2X GP4D 6S TL	83.3	2.36	1177	534
775/65R29 206A2 1X GP4D 6S TL	83.3	2.36	1205	547
775/65R29 213A2 2X GP4D HI-STABILITY 4S	83.3	2.36	1177	534
775/65R29 213A2 2X GP4D HI-STABILITY 6S	83.3	2.36	1177	534
775/65R29 GP-4D C1 1*+2* L-4/E-4 6S TL	83.3	2.36	1205	547
800/65R29 1X GP4D 6S TL	89.2	2.53	1205	547
800/65R29 2X GP4D 4S TL	89.2	2.53	1182	536
825-15 16 TR MS NYTT	2.1	0.06	95	43
825-15 16 TR MS NYTTT/C60504	5.2	0.15	104	47
825-15 24 XTRWL MSAR NYTT	6.1	0.17	136	61
825-15 24 XTRWL MSAR NYTT N0000	5.9	0.17	136	61
875/65R29 1X GP4D 6S TL	107.7	3.05	721	327
875/65R29 2X GP4D 2S TL	107.7	3.05	721	327
875/65R29 2X GP4D 4S E-4 TL	108.5	3.07	1549	702
875/65R29 2X GP4D 4S TL	107.7	3.05	1521	690
875/65R29 2X GP4D 6S E-4 TL	108.5	3.07	1530	694
875/65R29 2X GP4D 6S TL	107.7	3.05	1529	694
875/65R29 2X GP4D HI STABILITY 4S TL	108.5	3.07	1530	694
875/65R29 2X GP4D HI STABILITY 6S TL	108.5	3.07	1530	694
875/65R29 2X RL4D HI-STABILITY 6S L-4 TL	108.5	3.07	1685	764
875/65R29 C1 GP4D 4S L-4/E-4 TL	108.5	3.07	1569	712
875/65R29 C1 GP4D 6S L-4/E-4 TL	108.5	3.07	1522	690
875/65R29 GP-4D C1*+2* L-4/E-4 6S TL	108.5	3.07	721	327
875/65R33 1X RL-5K 6S TL	120.6	3.42	3584	1626
875/65R33 1X RL-5S 6S TL	120.6	3.42	3584	1626
875/65R33 2X RL-5K HI-STABILITY 20/20 TL	120.6	3.42	2659	1206
875/65R33 2X RL4K 20/20 L4 4S TL	120.6	3.42	2121	962
875/65R33 2X RL4K HG STAB 20/20L4 6S TL	120.6	3.42	2173	985

APPROXIMATE SHIPPING DATA

Size/Type	Tire Cubeage		Tire Weight	
	Ft ³	M ³	Lbs	Kg
875/65R33 2X RL5K HG STAB 20/20L5 6S TL	12.2	0.34	2629	1193
875/65R33 2X RL5K L5 6S TL	120.6	3.42	2695	1222
875/65R33 RL-5S HI-STABILITY 2X 6S TL	120.6	3.42	3584	1626
950-20 H SMO-5B NYTT	8.6	0.24	232	105
950-20 H SMO-5B NYTT C60505	10.5	0.30	262	119

TUBES, FLAPS AND VALVES INFORMATION FOR OFF-THE-ROAD TIRES

CONVENTIONAL SIZES

Tire Size	Ply Rating	Rim	Tube Size	Flap Size *	Angle Valve **
16.00-20/21	All	11.25	16.00-20/21 Truck	20/21F10.5	J1179B
16.00-24/25	All	11.25	16.00-24/25 Truck	24/25F9.6	J1175C
18.00-24	Thru 20	13.00	18.00-24/25 Truck	24/25F12.4	J1175C
18.00-24	24 and up	13.00		24/25F9.6	J1175C
18.00-25	12 thru 24	13.00	18.00-24/25 Truck	24/25F10.9	J1175C
18.00-25	28 and up	13.00	18.00-24/25 Truck	24/25F9.6	J1175C
18.00-33	All	13.00	18.00-32/33 Truck	33F8.9	J1076D
18.00-49	All	13.00			J1175C
21.00-25	24	15.00	21.00-24/25 Truck	24/25F12.4	J1179B
21.00-25	28 and up	15.00	21.00-24/25 Truck	24/25F10.9	J1179B
21.00-35	All	15.00	21.00-35 Truck	35F12.0	J1175C
21.00-49	All	15.00			J1175C
24.00-25	All	17.00	24.00-25 Truck	25F14.9	J1175C
24.00-29	All	17.00	24.00-29 Truck	29F15.0	J1175C
24.00-35	All	17.00	24.00-35 Truck	35F12.0	J1175C
24.00-49	All	17.00	24.00-49 Truck		J1175C
27.00-33	All	22.00	21.00-35 Truck	33F23.00	J1175C
27.00-49	All	19.50			J1175C
30.00-33	40	22.00	29.5-35 Truck	33F23.0	J1175C
36.00-51	All	26.00			J1175C

NOTE: Goodyear flaps are compounded to resist cracking and heat and they protect the tube from rim and bead toe injury in the tube-type assemblies between the rim and the tire.

** Valve J1014 is standard straight valve on all EM Tubes 16.00-20 and up. Angle Valve shown is most commonly used. Flap Width specified is minimum flap width. Flap width is measured on rim side of flap.

***EXAMPLE:** 24-9.0
24 + Nominal Diameter
9.0 + Flap Width

Consult your Goodyear Representative for Source of Manufacture.

WIDE BASE SIZES

Tire Size	Ply Rating	Rim	Tube Size	Flap Size *	Angle Valve **
20.5-25	All	17.00	20.5-25 Truck	25F14.9	J1175C
23.5-25	Thru 16	19.50		25F19.8	J1175C
23.5-25	20 and up	19.50	23.5-25 Truck	25F18.3	J1175C
26.5-25	Thru 16	22.00	26.5-25 Truck	25F21.6	J1175C
26.5-25	20 and up	22.00	26.5-25 Truck	25F19.8	J1175C
26.5-29	All	22.00	26.5-29 Truck	29F19.0	J1175C
29.5-25	16	25.00	29.5-25 Truck	25F23.1	J1175C
29.5-25	22 and up	25.00	29.5-25 Truck	25F21.6	J1175C
29.5-29	Thru 22	25.00	29.5-29 Truck	35F22.0	J1175C
29.5-29	28 and up	25.00	29.5-29 Truck		J1175C
29.5-35	All	25.00	29.5-35 Truck	35F22.0	J1175C
33.25-35	All	27.00	33.25-35 Truck		J1175C
33.5-33	Thru 26	28.00	33.35-35 Truck	33F25.0	J1175C
33.5-33	32 and up	28.00	33.25-35	33F23.00	J1175C
33.5-39	All	28.00	33.5-39 Truck		J1175C
37.5-33	All	32.00		33F25.0	J1175C
37.25-35	All	31.00	33.25-35 Truck		J1175C
37.5-39	All	32.00	37.5-39 Truck	39F27.0	J1175C
37.5-51	All	32.00			J1175C

NOTE: Goodyear flaps are compounded to resist cracking and heat and they protect the tube from rim and bead toe injury in the tube-type assemblies between the rim and the tire.

** Valve J1014 is standard straight valve on all EM Tubes 16.00-20 and up. Angle Valve shown is most commonly used. Flap Width specified is minimum flap width. Flap width is measured on rim side of flap.

***EXAMPLE:** 24-9.0
 24 + Nominal Diameter
 9.0 + Flap Width

Consult your Goodyear Representative for Source of Manufacture.

GRADER TIRES

TIRES USING FLAT BASE RIMS

Tire Size	Rim	Tube Size	Valve No.	Flap Size
8.25-20TG	6.50T	8.25-20TR	TR77A/TR462	20F7.0

TIRES USING SEMI-DROP CENTER RIMS

7.50-20TG	5.50-DC	7.50-20T	TR177A/TR461	20-7.0
10.00-24TG	8.00TG	10.00/11.00/12.00-24GR	218A	24-8.4RG
12.00-24TG	8.00TG	10.00/11.00/12.00-24GR	218A	24-8.4RG
13.00-20TG	8.00TG	13.00/14.00-20GR	218A	20-9.6RG
13.00-24TG	8.00TG	13.00/14.00-24GR	220A	24-8.4RG
14.00-20TG	8.00TG, 10.00VA	13.00/14.00-20GR	218A*	20-9.6RG
14.00-24TG	8.00TG, 10.00VA	13.00/14.00-24GR	200A	24-10.0RG
16.00-20TG	10.00VA	13.00/14.00-20GR	220A	20-9.6RG
16.00-24TG	10.00VA	16.00-24GR	220A	24-10.0RG
18.00-26	DW16-DC	23.1-26 (18.00-26) Farm	218A	

* When used on a 10.00 rim, TR220A valve should be used.

SAND TIRES

Tire Size	Rim	Tube Size	Rec. Valves	Flap Size
9.00-15 DT	5-1/2K-Dc	9.00-15 Truck	TR175A/TR463	15-6.0
9.00-16 DT	6.50H	9.00-16 Truck	TR177A/TR461	16/16.5-7.0LT
11.00-16 DT	6.50H		TR177A/TR461	16/16.5-7.0LT
16.00-16 DT	6.50H	16.00-16 Truck	TR177A/TR461	16/16.5-7.0LT
14.00-20 DT	10.00W	13.00/14.00-20 Truck	TR179A/TR465	20/21F10.5
16.00-20 DT	10.00W	16.00-20/21 Truck	SP1000	20F9.0
24-20.5 DT	18.00DC		J1175C	21-20.0
24-21 DT	18.00		J1175C	21-20.0
27.25-21 DT	19.50		J1014	21-20.0
18.00-25 DT	10.00	18.00-24/25 Truck	J1175C	24/25F10.5
21.00-25 DT	15.00	21.0-24/25 Truck	J1179B	24/25F13.0
29.5-25 DT	25.00	29.5-25 Truck	J1175C	25F23.1

Consult your Goodyear Representative for Source of Manufacture.

TYPE I, II AND III TRUCK RIMS

Tire & Tube Size	Rim	Valve	Flat Size
8.25-20	6.50T	TR77A/TR462	20F7.0
9.00-20	7.00T	TR175A/TR463	20F8.0
10.00-20	7.50V	TR78A/TR464	20F8.0
10.00-22	7.50V	TR78A/TR464	22F8.0
11.00-20	8.00V	TR78A/TR464	20F8.0
11.00-22	8.00V	TR78A/TR464	22F8.0

Tire & Tube Size	Rim	Valve	Flat Size
11.00-24	8.00V	TR78A/TR464	24F8.0
12.00-20	8.50V	TR78A/TR464	20F8.0
12.00-24	8.50V	TR78A/TR464	24F8.0
13.00-24	13.00/14.00-24/25;17.5-25	10.00W TR179A/TR465	24F9.0
14.00-20	13.00/14.00-20	10.00W TR179A/TR465	20F10.0
14.00-24	13.00/14.00-24/25;17.5-25	10.00W TR179A/TR465	24F9.0

Flap width specified is minimum flap width. Flap width is measured on rim side of flap.

Consult your Goodyear Representative for Source of Manufacture.

TUBES AND FLAPS

Only use radial type tubes and flaps in radial tires (see special marking on tubes or flaps). Preferably fit a new tube and a new flap when mounting a new tire.

TUBES

A tube too large will be liable to buckling, and to early failure. A tube too small will be stretched excessively, leading to reduced rub resistance, and worse air retention. In an emergency, a small tube is better than a large tube, since the failure mode is less likely to be catastrophic.

In case of necessity, a tube may be reused if,

- There is no apparent damage
- The tube has not grown excessively during the first life

FLAPS

The flap is designed to:

- Protect the tube from the roughness of the rim
- Prevent the tube being pinched by the component parts of multi-pieced rims
- Prevent the tube being pushed through the valve slot

As a rule, flaps are necessary for any rim which has a valve slot against a valve hole.

Note: The fitment of tubes to "tubeless" tires is not recommended.

SUPER LARGE BORE VALVE

The Super Large Bore Valve was designed in answer to the many requests for a valve which would save time inflating and deflating earthmover tires. It fits the standard 13/16" valve holes. No need to rebores your rims, if your present hole is on center. If valve hole is under bead seat band, it must be moved out, preferably on center.



TURRET TYPE VALVE

CH-8 CORE HOUSING



SWIVEL TYPE VALVE

CH-8 CORE HOUSING



INFLATING ADAPTOR

EARTHMOVER TUBE VALVES

LARGE BORE TUBE VALVES (SWIVEL TYPE)

TIRE AND RIM ASSOCIATION STANDARD

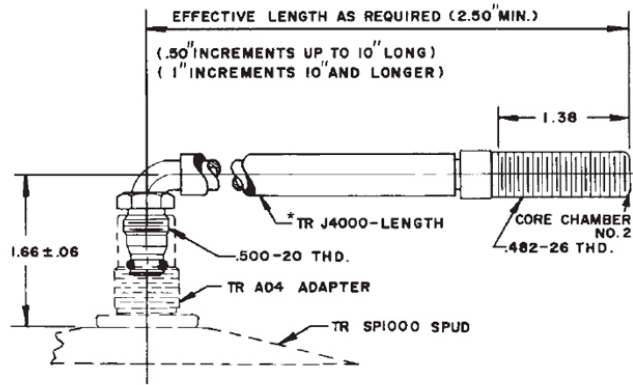

*Stems are specified as TR J4000-Length.

Example: For An effective length of 9.50", the stem number is TR J4000-9.50.

Recommended installation torque: 70-80 inch-pounds.

Valve core: TR C2

LARGE BORE TUBE SPUD ADAPTOR - TR AD4

TIRE AND RIM ASSOCIATION STANDARD

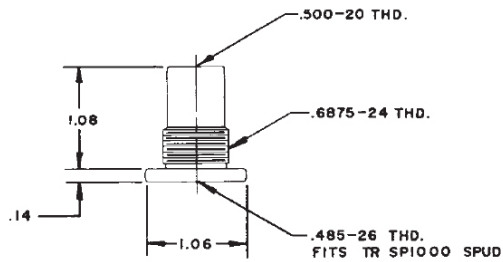

Note: TR AD4 Adaptor combined with TR SP1000 Spud is equivalent to TR SP4000 Spud.

LARGE BORE TUBE VALVES (STRAIGHT AND SWIVEL TYPE)

TIRE AND RIM ASSOCIATION STANDARD

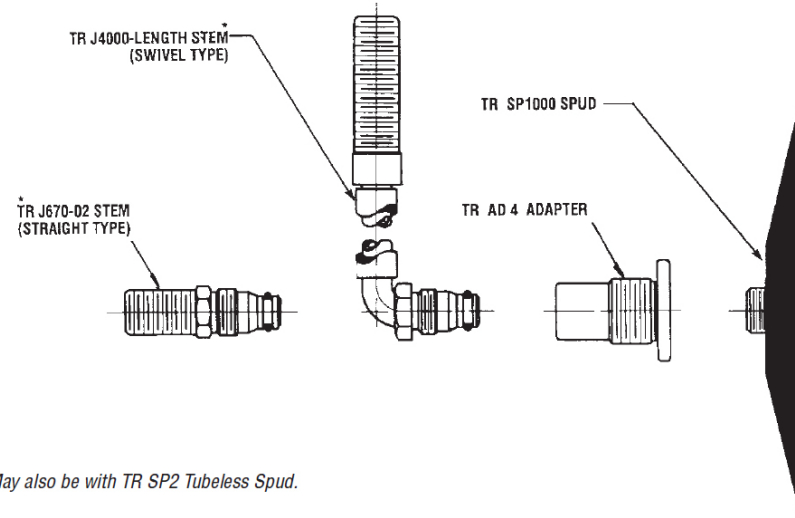

*May also be with TR SP2 Tubeless Spud.

LARGE BORE TUBE VALVE (STRAIGHT TYPE)

TIRE AND RIM ASSOCIATION STANDARD

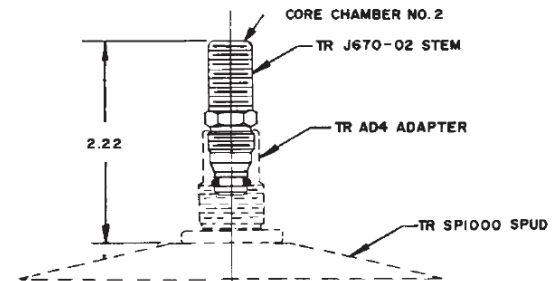

Recommended installation torque: 70-80 inch-pounds.

Valve core: TR C2

EARTHMOVER TUBE VALVES

CONVERTIBLE TUBE VALVES AIR-LIQUID TYPE

TIRE AND RIM ASSOCIATION STANDARD

TR VALVE NO.	A	B (REF.)
400	3.35 (85)	3.0 (75)
411	4.13 (105)	3.7 (95)
442	4.53 (115)	4.1 (105)
443	4.92 (125)	4.5 (115)
444	5.51 (140)	5.1 (130)
445	6.10 (155)	5.7 (145)

Valve Core: TR C1 (Short core only)

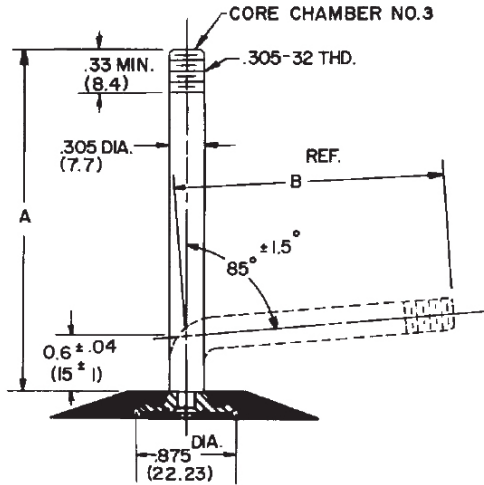

Dimensions in Inches (Millimeters)

CONVERTIBLE TUBE VALVES AIR-LIQUID TYPE

TIRE AND RIM ASSOCIATION STANDARD

TR VALVE NO.	A	B (REF.)
460	3.35 (85)	3.0 (75)
461	4.13 (105)	3.7 (95)
462	4.53 (115)	4.1 (105)
463	4.92 (125)	4.5 (115)
464	5.51 (140)	5.1 (130)
465	6.10 (155)	5.7 (145)

Valve Core: TR C1

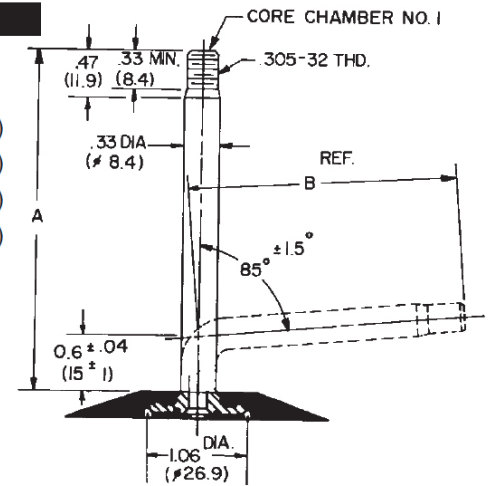

Units—In. (mm)

SCREW-ON STANDARD BORE TUBE VALVES

TIRE AND RIM ASSOCIATION STANDARD

TR VALVE NO.	B
1075A	3.0
1077A	4.1
1078A	5.0
1175A	4.5
1177A	3.7
1179A	5.6

Valve Core: TR C1

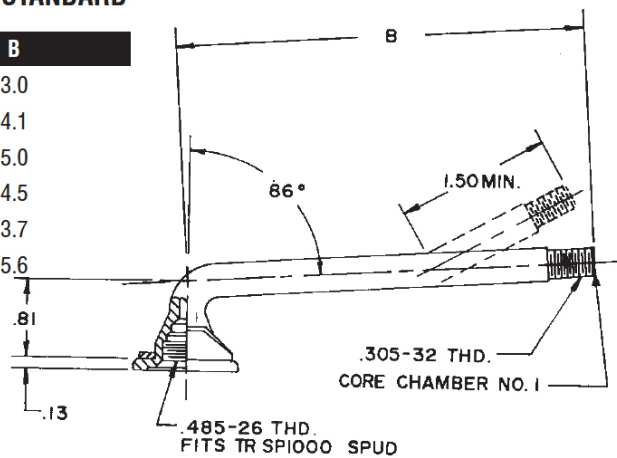

SCREW-ON LARGE BORE CONVERTIBLE TUBE VALVES

TIRE AND RIM ASSOCIATION STANDARD

TR VALVE NO.	FORM	A	A ₁	B	J	Z°
J1014	A	1.91	—	—	1.44	—
J1076	A	4.16	—	—	.75	—
	D	—	2.06	2.31	.75	90
	E	—	1.38	3.00	.75	88
J1175	A	5.28	—	—	.75	—
	C	—	1.38	4.13	.75	88
J1078	A	5.78	—	—	.75	—
	B	—	1.38	4.62	.75	82
J1179	A	6.41	—	—	.75	—
	B	—	1.38	5.25	.75	88

Valve Core: TR C2

TR SP1000 SPUD (AIR LIQUID TYPE)

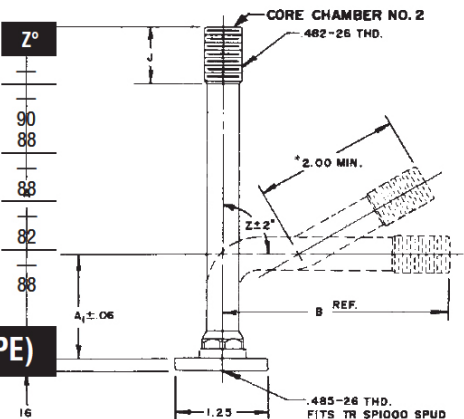

*Required for valve core sealing

SIZE	MEASURING RIM	APPROVED ALTERNATE RIM
7.00-20 NHS	5.50 S	6.00 S
7.50-15 K	6L, 6 LB (DC)	5.50 F (SDC)
7.50-20 NHS	6.00 S	6.50 T
7.50-20 TG	6.00 S	6.50 T
8.25-20 NHS	6.50 T	7.00 T
8.25-20 TG	6.50 T	7.00 T
9.00-15 DT	5 1/2 K, 5.50F	
9.00-16 DT	6.50 H	
9.00-20 NHS	7.00 T	7.50 V
10.00-20 NHS	7.50 V	8.00 V
10.00-24 TG	8.00 TG (SDC)	
11.00-16 DT	6.50 H	
11.00-20 NHS	8.00 V	8.50 V
12.00-20 NHS	8.50 V	9.00 V
12.00-21 NHS	8.50	
12.00-24 NHS	8.50 V	9.00 V
12.00-24 TG	8.00 TG	
12.00-25 NHS	8.50	
13.00-20 TG	8.00 TG	
13.00-24 NHS	10.00 W	9.00 V
13.00-24 TG	8.00 TG (14 PR Max)	10.00 VA (16 PR)
13.00-25 NHS	10.00	
14.00-20 NHS	10.00 W	
14.00-20 TG	8.00 TG (14 PR Max)	10.00 VA (16 PR)
14.00-21 NHS	10.00	
14.00-24 NHS	10.00 W	
14.00-24 TG	8.00 TG (14 PR Max)	10.00 VA (16 PR)
14.00-25 NHS	10.00	
15.5-25	12.00-1.3	13.00 LR-DC (12 PR/*MAX) 12.00-1.3 (SDC)
16.00-20	10.00 W	

SIZE	MEASURING RIM	APPROVED ALTERNATE RIM
16.00-20 DT	10.00 W	
16.00-20 TG	10.00 VA	
16.00-21 NHS	11.25-2.0	10.00-1.5
16.00-24 TG	10.00 VA	
16.00-25	11.25-2.0	
17.5-25	14.00-1.5	13.00 LR-DC (12 PR/*MAX) 14.00-1.3 (SDC)
18.00-25	13.00-2.5	
61x18.00-25	13.00-2.5	
18.00-25 DT	10.00 T	
18.00-26	DW-16 (drop center rim)	
18.00-33	13.00-2.5	
18.00-49	13.00-2.75	
20.5-25	17.00-2.0	17.00 AL (16PR MAX)
21.00-25	15.00-3.0	
21.00-25 DT	15.00-3.0	
21.00-35	15.00-3.0	
21.00-49	15.00-3.0	
23.5-25	19.50-2.5	
24.00-25	17.00-3.5	
24.00-29	17.00-3.5	
24.00-35	17.00-3.5	
24.00-43	17.00-3.5	
24.00-49	17.00-3.5	
24.00-51	17.00-3.5	
26.5-25	22.00-3.0	
26.5-29	22.00-3.0	
27.00-33	22.00-4.0	
27.00-49	19.50-4.0	
27.00-51	19.50-4.0	
27-56.5	20.0-1.25	21.0-1.25

Consult your Goodyear Representative for Source of manufacture.

Use Arctic O-Rings and valves when ambient temperature is below -30°F (-34°C)

SIZE	MEASURING RIM	APPROVED ALTERNATE RIM
29.5-25	25.00-3.5	
29.5-29	25.00-3.5	24.00-3.5, 26.00-3.5
29.5-25 DT	25.00-3.5	
29.5-35	25.00-3.5	27.00-3.5
30.00-33	22.00-4.5	
30.00-51	22.00-4.5	
30-56.5	22.0-1.25	21.0-1.25
33.00-51	24.00-5.0	
33.25-29	27.00-3.5	26.00-3.5
33.25-35	27.00-3.5	29.00-3.5
33.5-33	28.00-4.0	
33.5-39	28.00-4.0	
36.00-51	26.00-5.0	
36.00-51 DT	26.00-5.0	
37.00-57	27.00-6.0	
37.25-35	31.00-4.0	
37.5-33	32.00-4.5	
37.5-39	32.00-4.5	
37.5-51	32.00-4.5	
38-39	28.00-4.0	
40.00-57	29.00-6.0	27.00-6.0
46/90R57	32.00-6.0	29.00-6.0
41.25/70-39	32.00-4.5	
49.5-57	36.00-6.0	
50/80-57	36.00-6.0	
52/80-57	36.00-6.0	
550/65R25	14.00-1.5	14.00-1.3
600/65R25	17.00-2.0	17.00-1.7
650/65R25	19.50-2.5	17.00-1.7/2.0
750/65R25(30/65R25)	24.00-3.0	22.00-3.0

SIZE	MEASURING RIM	APPROVED ALTERNATE RIM
800/65R29	24.00-3.0	25.00-3.0
875/65R29	27.00-3.0	25.00-3.0
30/65-29	24.00-3.0	
35/65-33	28.00-3.5	
40/65-39	32.00-4.0	
46/65-45	36.00-4.5	
50/65-51	40.00-4.5	
53/80R63	36.00-5.0	38.00-5.0
59/80R63	44.00-5.0	41.00-5.0

Consult your Goodyear Representative for Source of manufacture.

Use Arctic O-Rings and valves when ambient temperature is below -30°F (-34°C)

O-RINGS

Rim Diameter	Part Number	A (in)	B (in)	Weight
20	OR220TG	18.25	0.26	0.13
21	OR21T	19.25	0.26	0.14
24	OR224TG	22	0.26	0.15
25	OR25T	22.75	0.26	0.16
25	OR325T	22.44	0.385	0.3
29	OR329T	26.25	0.385	0.4
33	OR333T	30.13	0.385	0.5
35	OR335T	32.13	0.385	0.5
39	OR339T	36.13	0.385	0.6
45	OR345T	41.13	0.385	0.7
49	OR349T	45.13	0.385	0.7
51	OR451T	46	0.5	1.2
57	OR457T	51.63	0.5	1.3
63	OR463T	57.273	0.5	1.44

Nominal Rim Diam.	Basic Rim Type	Part No.	Sealing Ring Diam. - A	Cross Section - B (in)	Cross Section - B (mm)
20"	JM	OR20JM	19.125	0.230	5.8
21"	T	OR21T	19.250	0.260	6.6
25"	T	OR25T	23.250	0.260	6.6
20"	TG	OR220TG	18.250	0.260	6.6
24"	TG	OR224TG	22.000	0.260	6.6
25"	STN-HTN	OR325T	22.438	0.385	9.8
29"	HTS-HTHM	OR329T	26.250	0.385	9.8
33"	HTHM-RW	OR333T	30.125	0.385	9.8
35"	HTS-HTHM	OR335T	32.125	0.385	9.8
39"	HTS-HTHM	OR339T	36.125	0.385	9.8
49"	HTHM-RW	OR349T	45.125	0.385	9.8
51"	HTS-HTHM	OR351T	47.125	0.385	9.8
51"	HDT	OR451T	46.000	0.500	12.7
57"	HDT	OR457T	51.625	0.500	12.7

O-Ring	Tire Size				
OR225	15.5-25	17.5-25			
OR325	18.00-25	20.5-25	23.5-25	26.5-25	29.5-25
OR329	26.5-29	29.5-29	30/65-29	33.25-29	
OR333	18.00-33	33.5-33	35/65-33	27.5-33	
OR335	21.00-35	24.00-35	29.5-35	33.25-35	

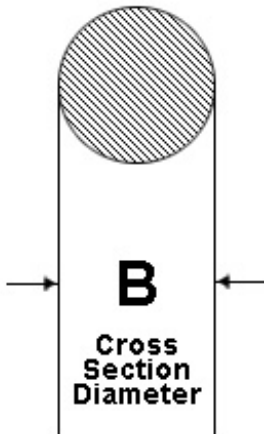
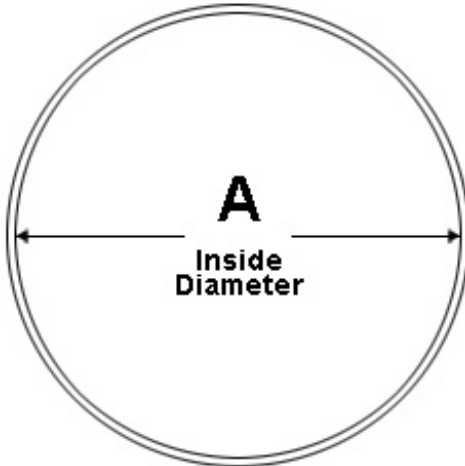

ARCTIC "O" RINGS

Specifically compounded "O" rings for sub-zero temperatures. Engineered to function and create seal at -65°F. "O" rings are further identified with a green band around section circumference close to part number. Add "A" to part number for Arctic "O" ring (for example: OR335TA).

EARTHMOVER RIM STYLES

THREE PIECE HEAVY DUTY TRUCK

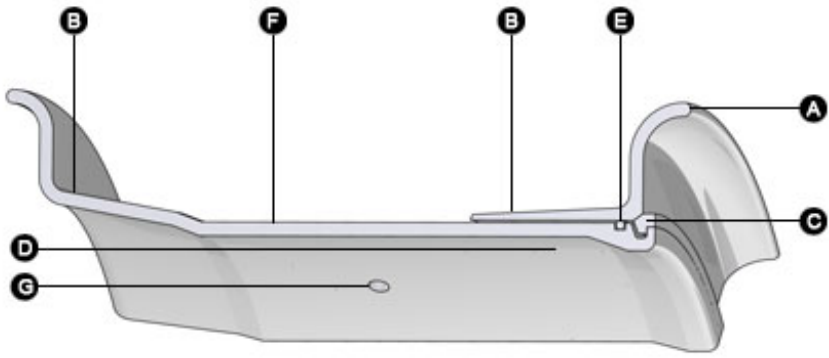

- A** Side Flange
- B** Tapered Bead Seats
- C** Lock Ring
- D** Mounting Bevel
- E** Sealing Ring
- F** Rim Base
- G** Embossed Valve Hole

THREE PIECE GRADER

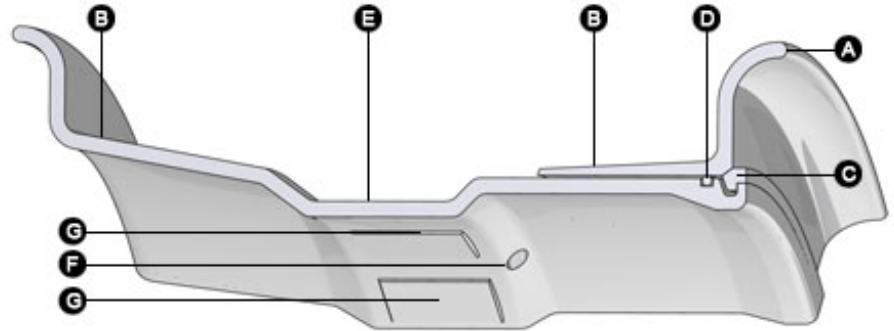

- A** Side Flange
- B** Tapered Bead Seats
- C** Lock Ring
- D** Sealing Ring
- E** Rim Base
- F** Embossed Valve Hole
- G** Locating Lugs

FIVE PIECE HEAVY DUTY AND WIDE BASE

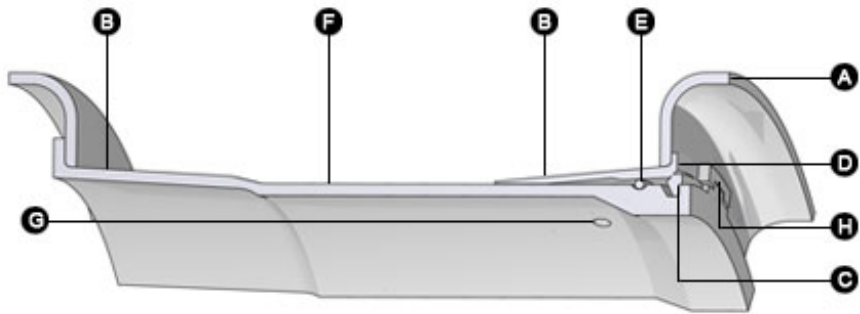

- A** Side Flange
- B** Tapered Bead Seats
- C** Lock Ring
- D** Pry Bar Pockets
- E** Sealing Ring
- F** Rim Base
- G** Valve Hole
- H** Bead Seat Band Driver

FIVE PIECE EXTRA HEAVY DUTY

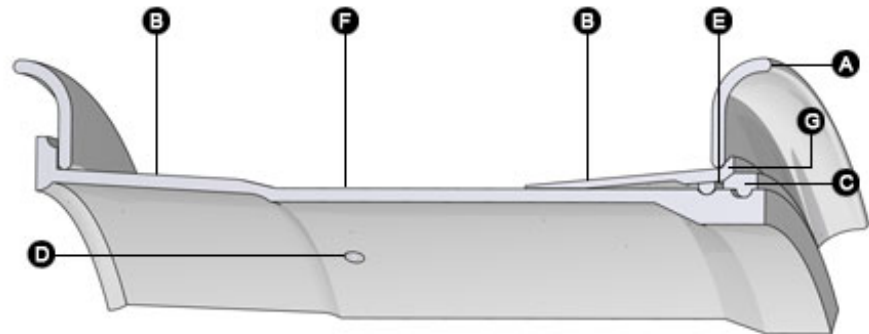

- A** Heavy Side Flange
- B** Tapered Bead Seats
- C** Lock Ring
- D** Valve Hole
- E** Sealing Ring
- F** Rim Base
- G** Circumferential Pry Bar Groove

EARTHMOVER RIM STYLES

SEVEN PIECE SPEED WHEEL

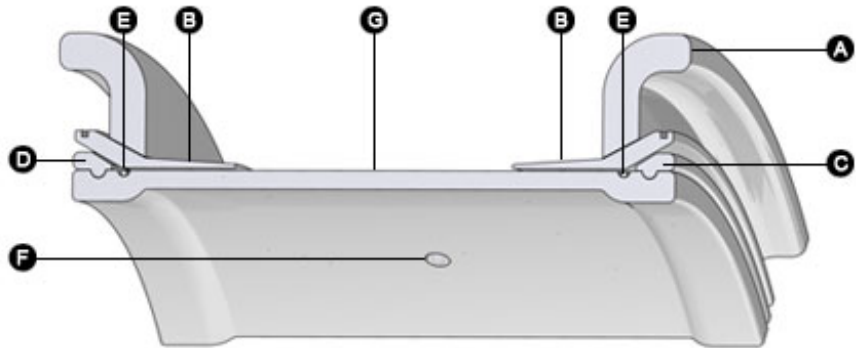

- A** Heavy Side Flange
- B** Tapered Bead Seats
- C** Lock Ring
- D** Two Piece Bolt Together Lock Ring
- E** Sealing "O" Ring
- F** Valve Hole
- G** Rim Base

